

REVISED AEROQUIP DESIGN:  
ALL DRAWINGS PREDATING  
THIS DRAWING ARE OBSOLETE

**FINAL DRAWING  
APPROVED: JPC**

REVISION HISTORY				
ZONE	REV	DESCRIPTION	DATE	APPROVED
	1	ADDED .125 RADIUS TO PREVENT RISER TEARING	1/10/2011	
	1	FLAT ALL THE WAY ACROSS	1/10/2011	
	1			

- NOTES:**  
**1) MATERIAL IS PVC**  
**2) ADD .125 RADIUS TO 5 EXISTING PARTS**

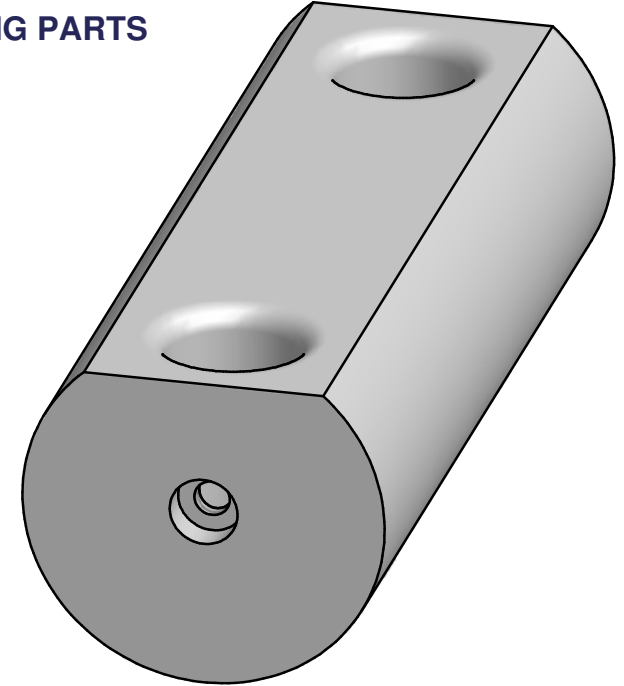
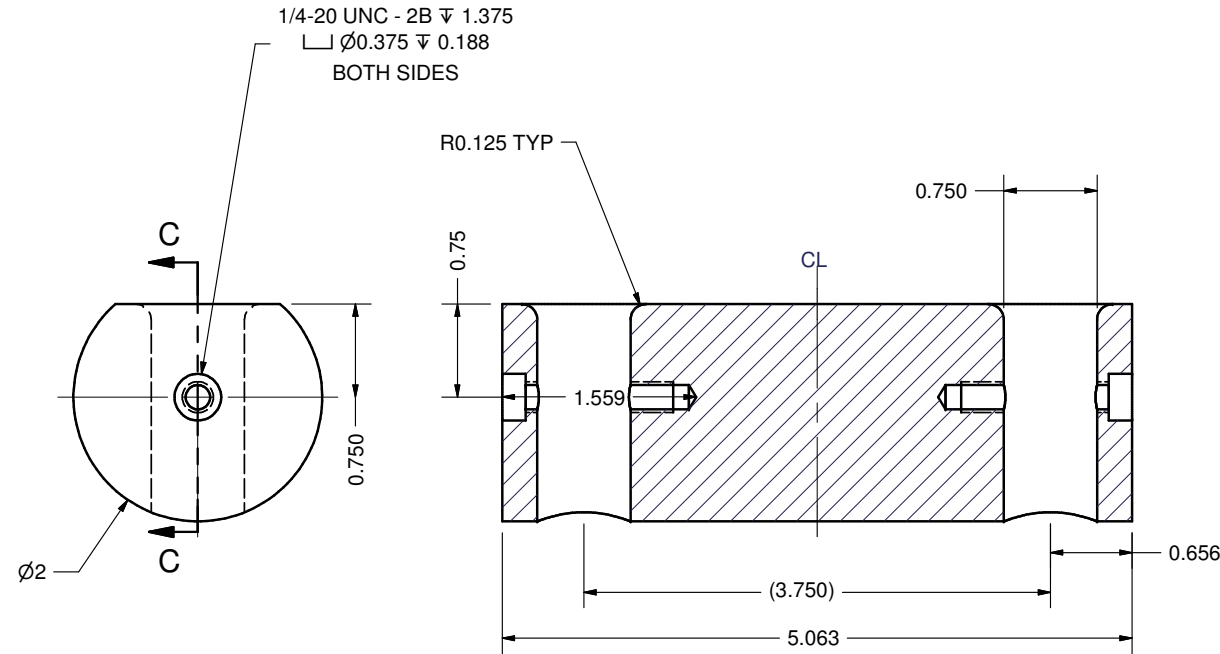

**SECTION C-C  
SCALE 1**

TOLERANCES: (UNLESS SPECIFIED OTHERWISE) .X = $\pm$ .030 .XX = $\pm$ .010 .XXX = $\pm$ .005 A/B = $\pm$ .0625 X' = $\pm$ 1'	DRAWN	DC	1/31/2011	University of Hawaii-SOEST	
	CHECKED				
	IMFG			TITLE	
	APPROVED			Quick Conect Handle	
	SIZE	B	DWG NO	QC-HandleRev1	REV
	SCALE				1
			SHEET 1 OF 1		