

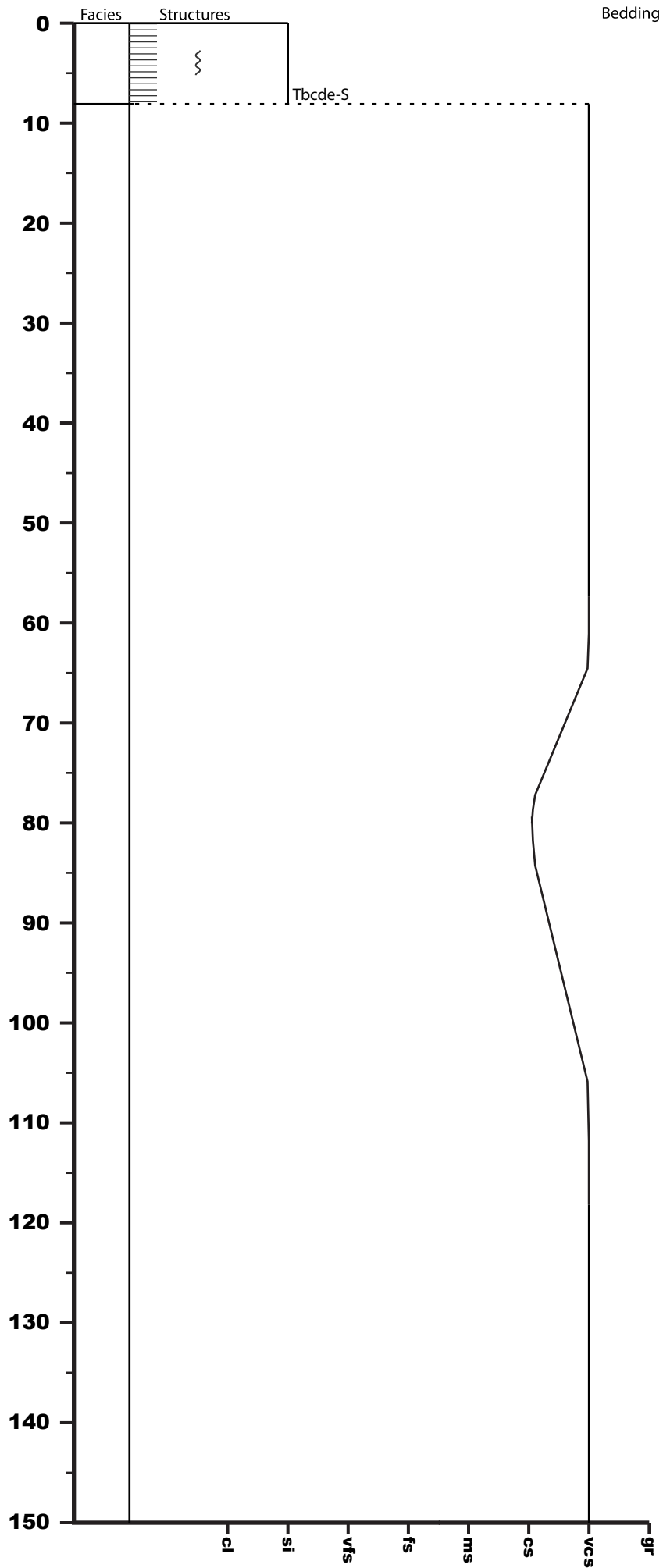

U1438D-58R-3

755.13 - 756.31 mbsf

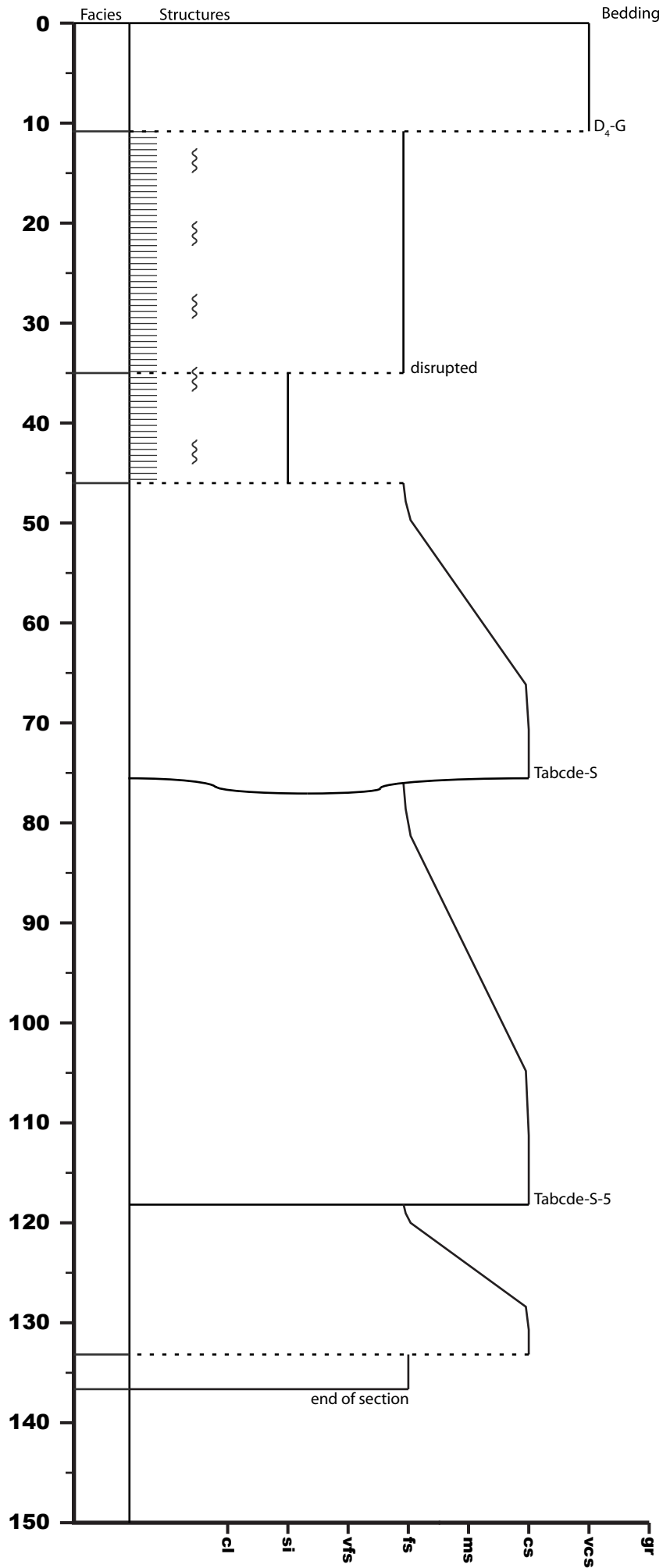



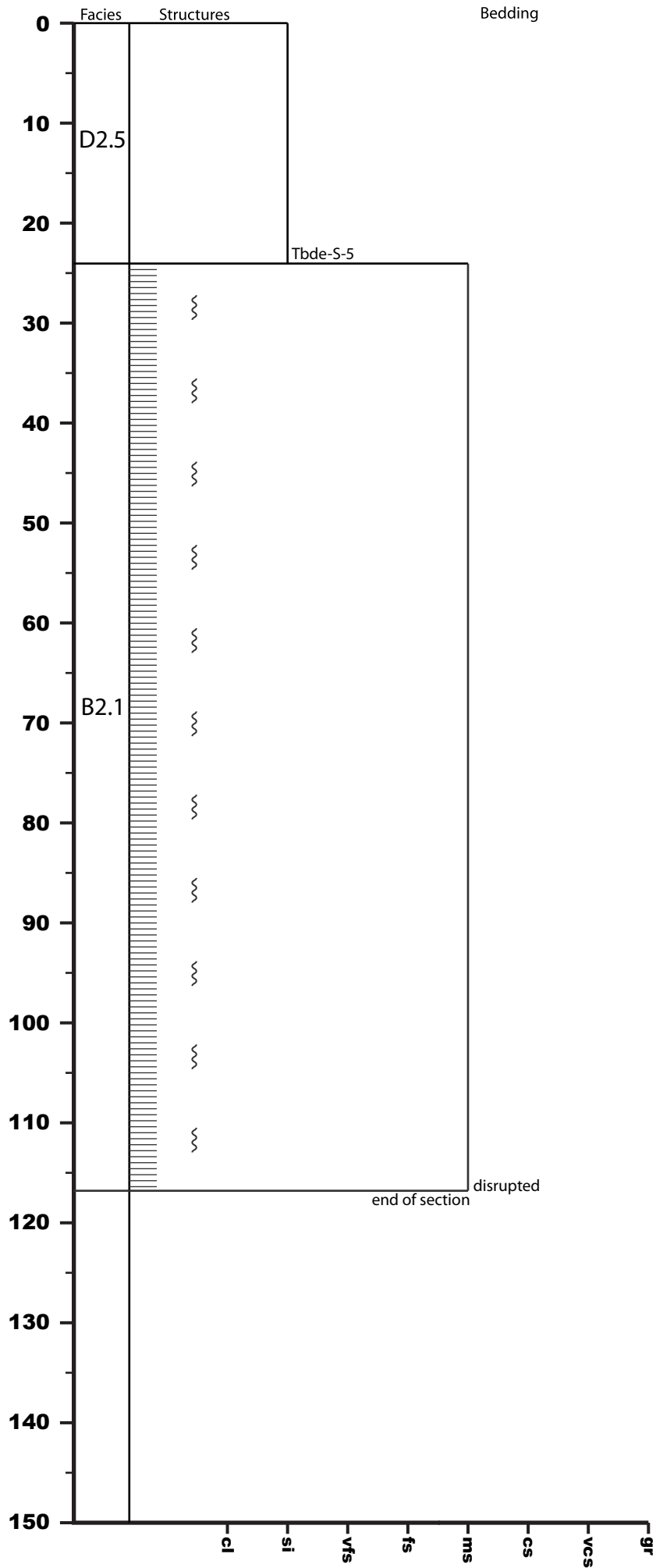

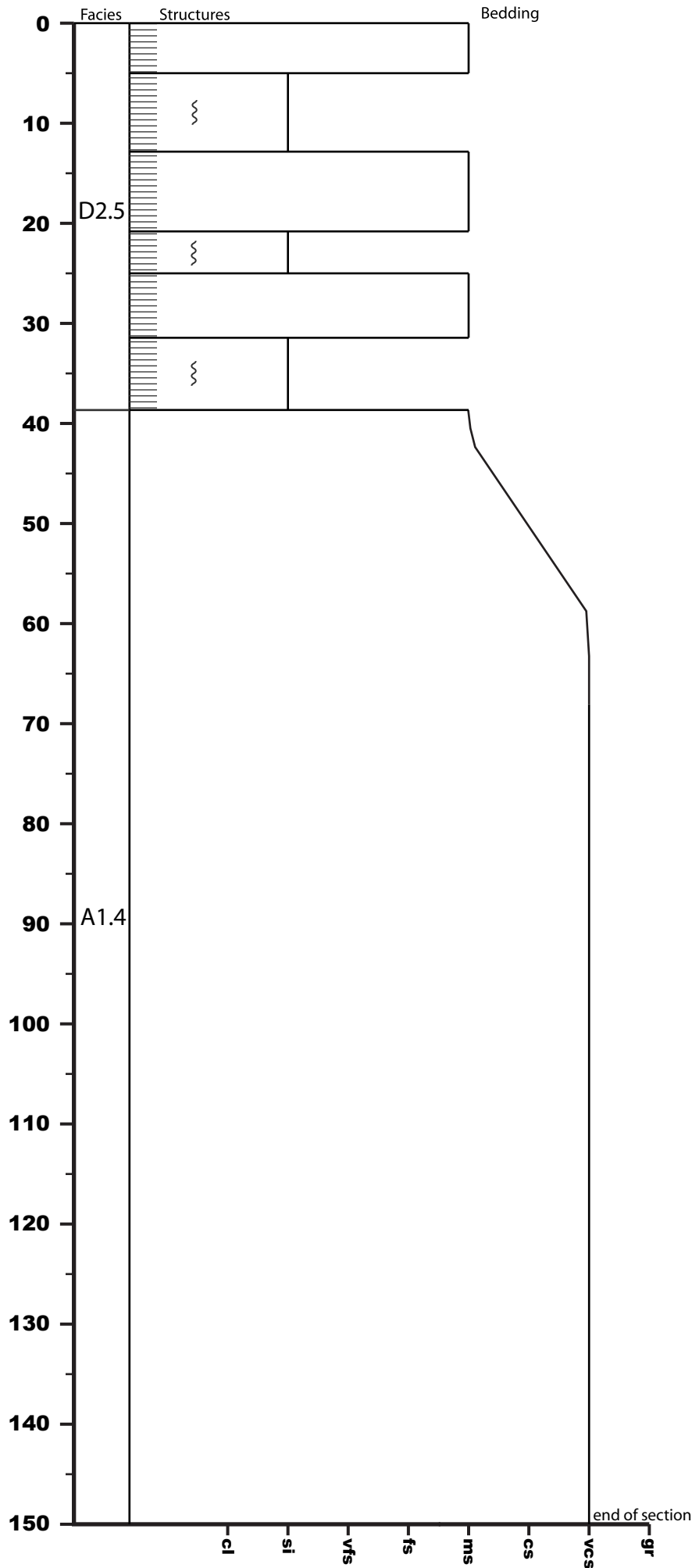

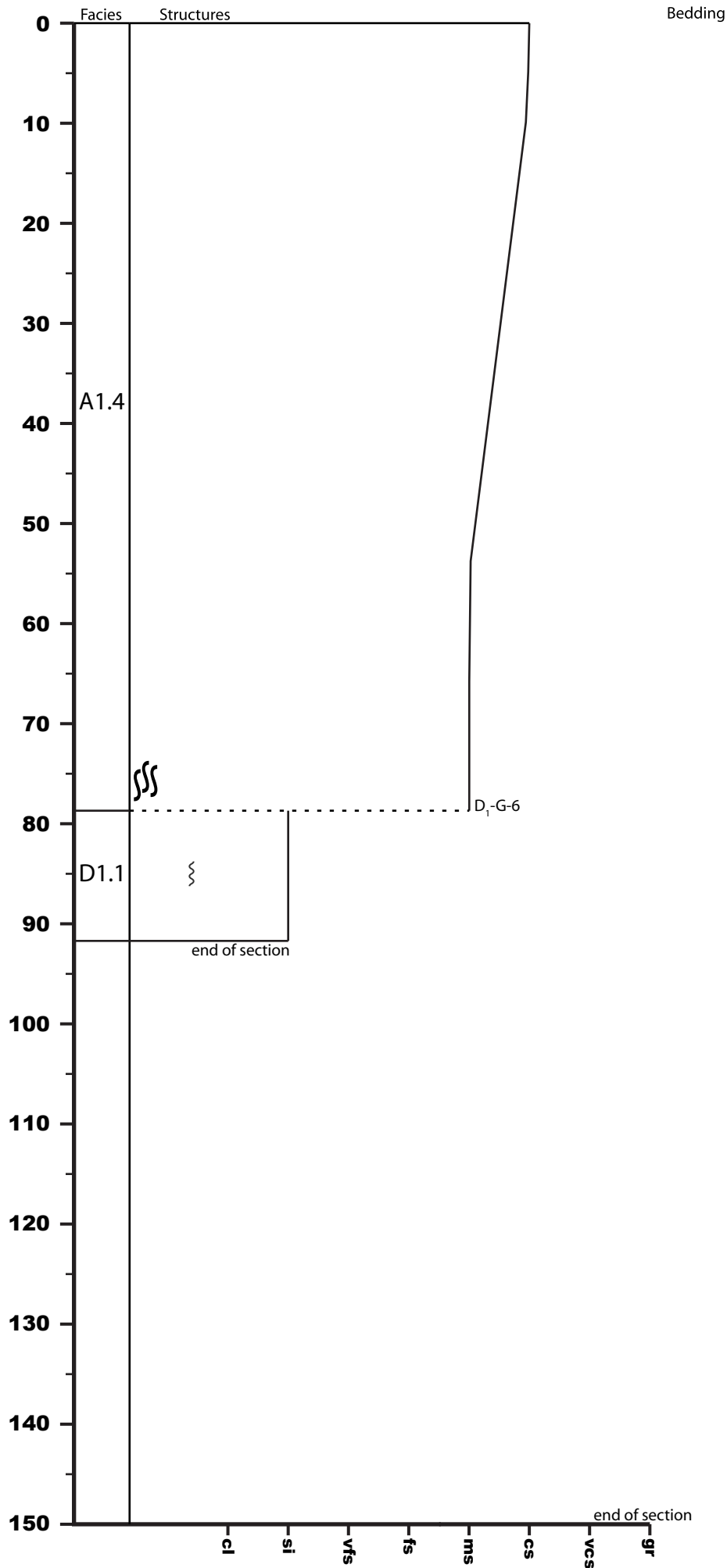

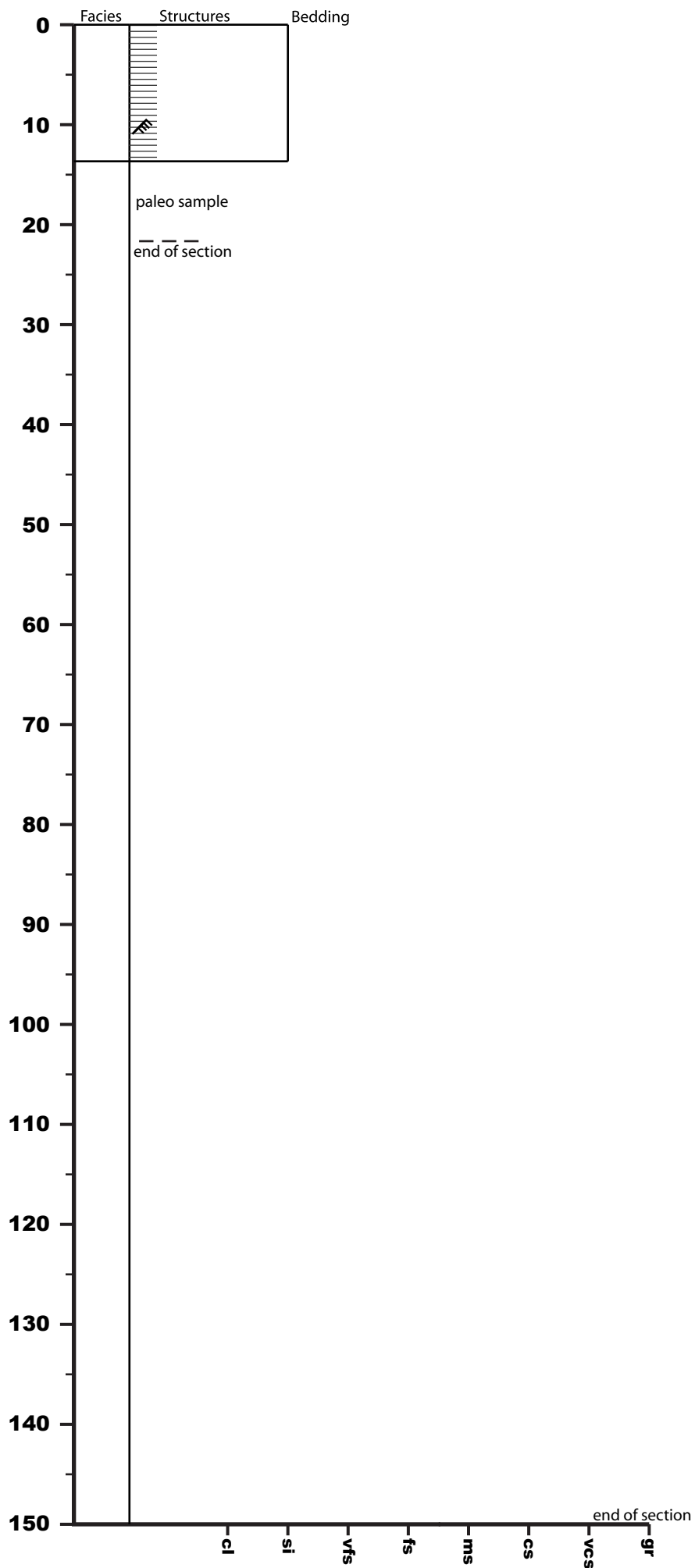

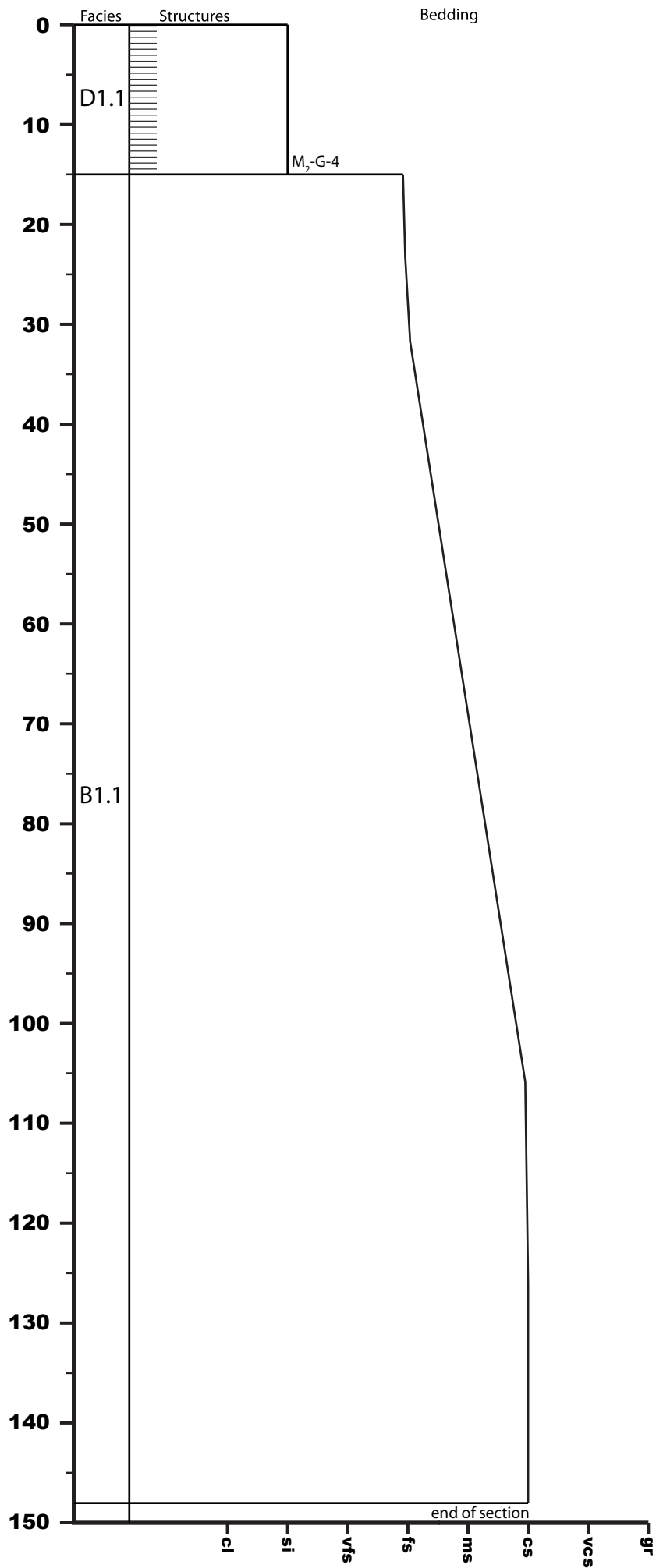

U1438D-59R-2

763.48 - 764.83 mbsf

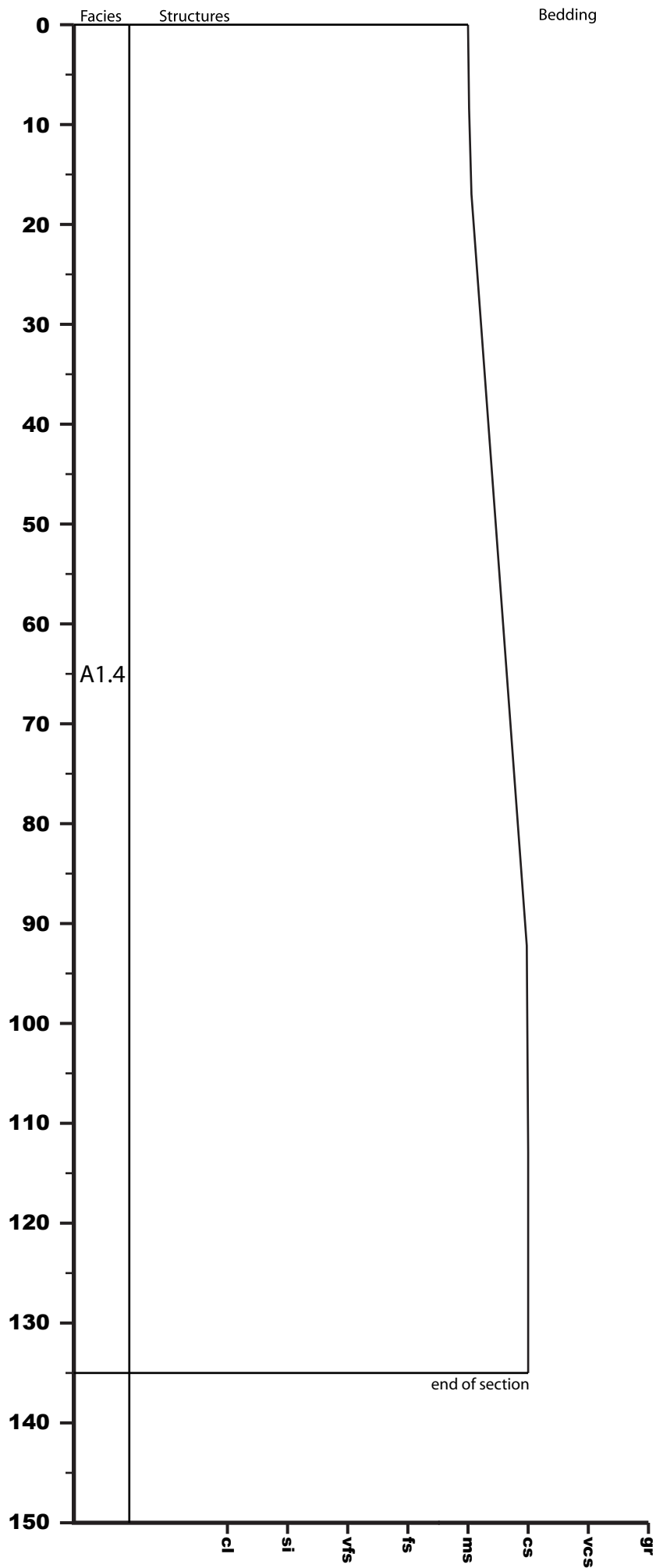



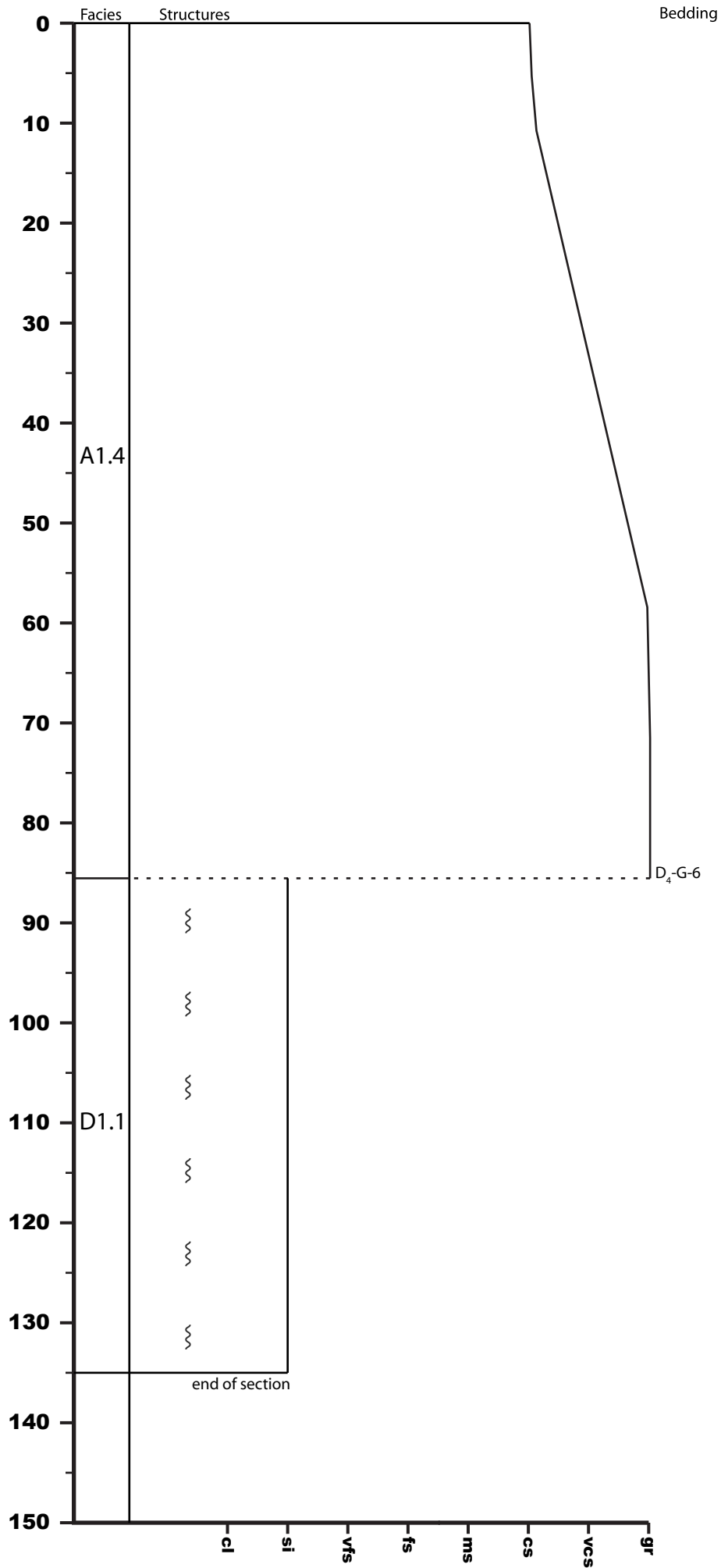

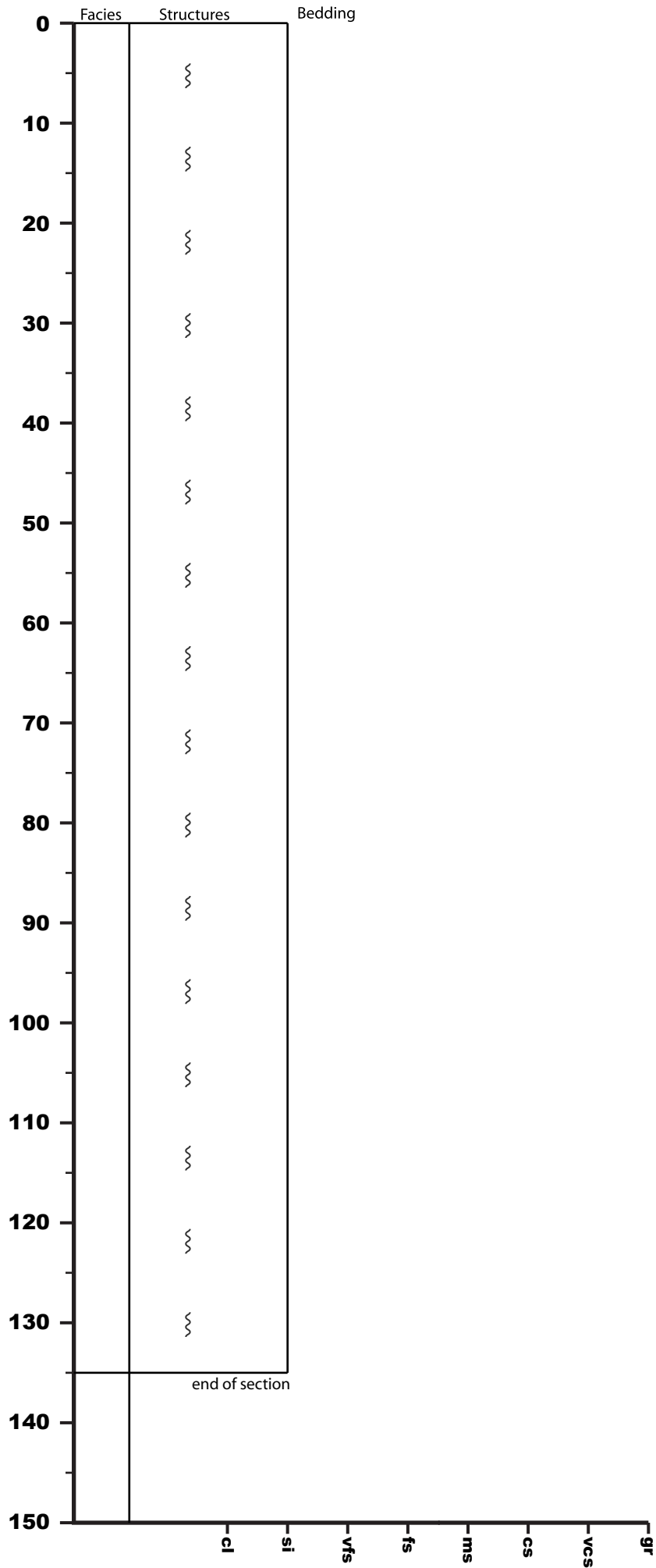

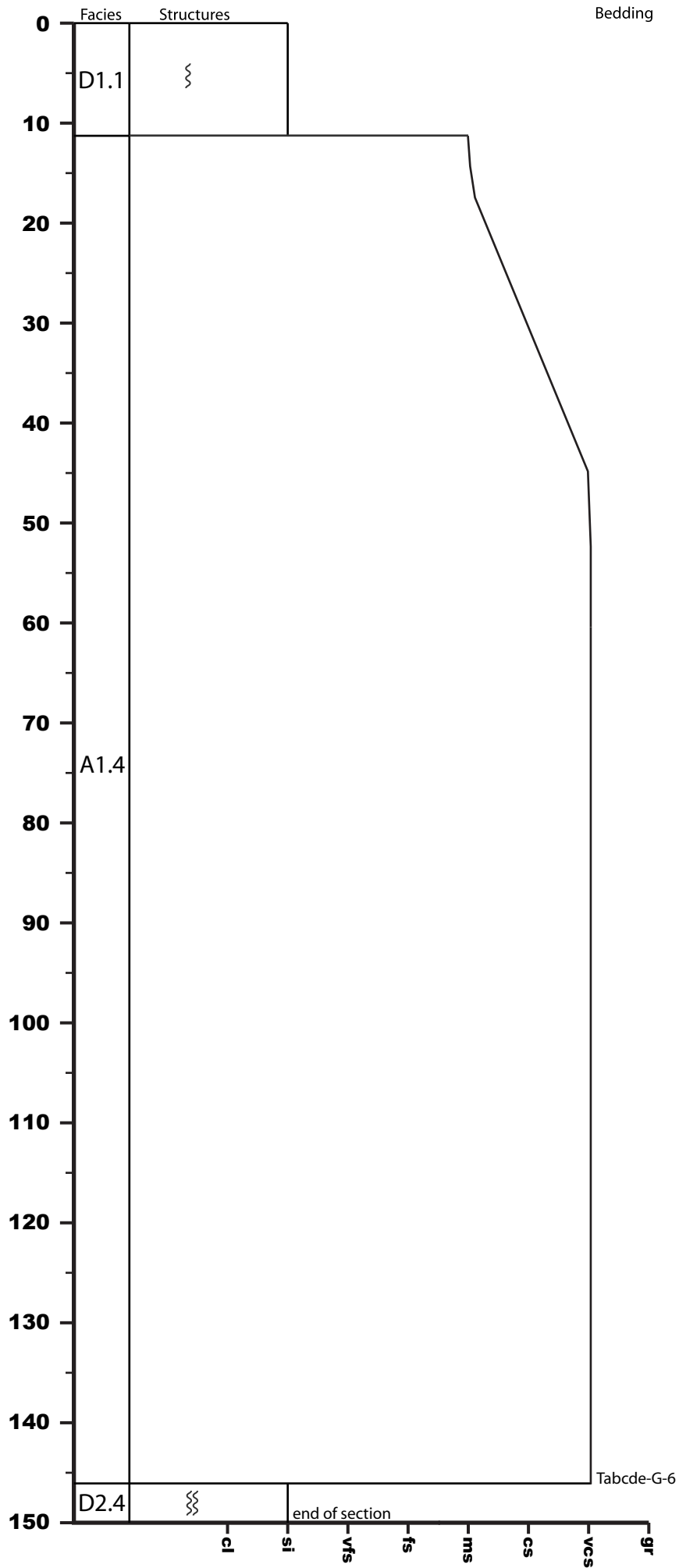

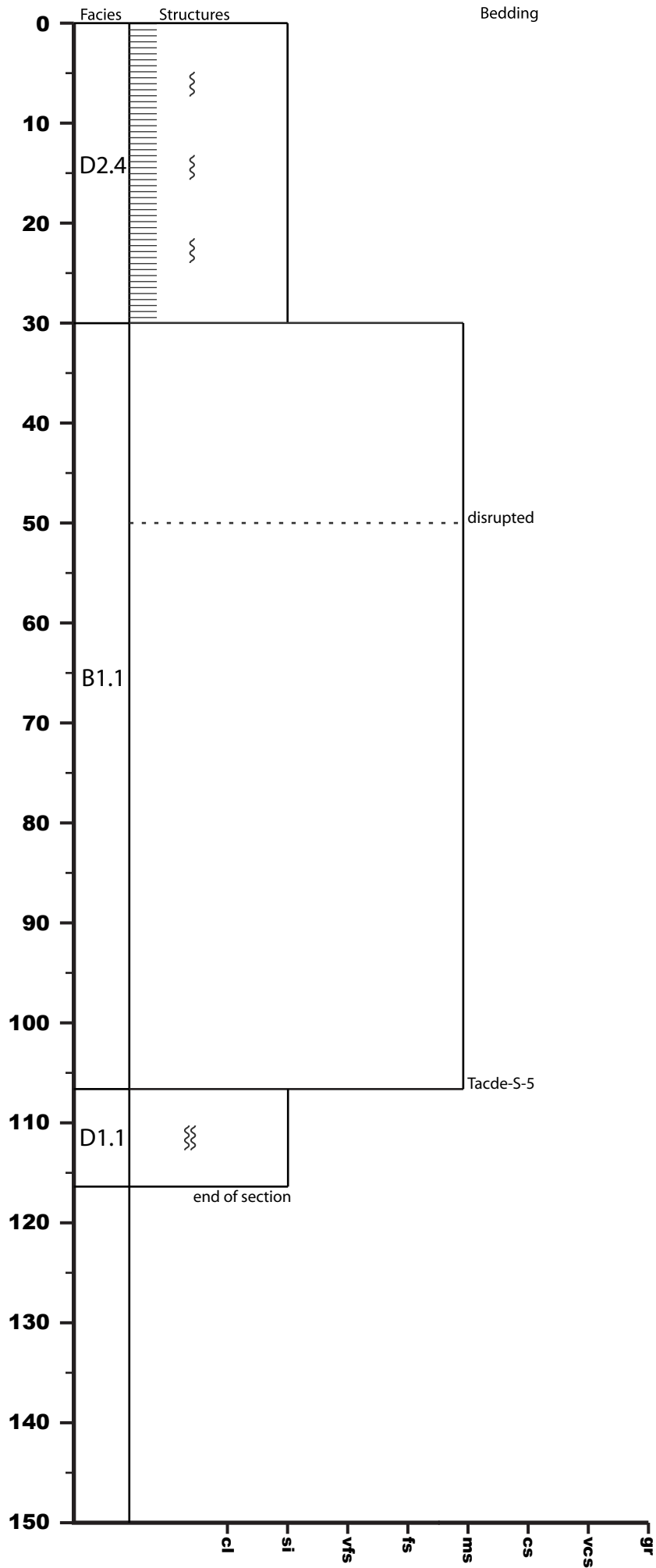

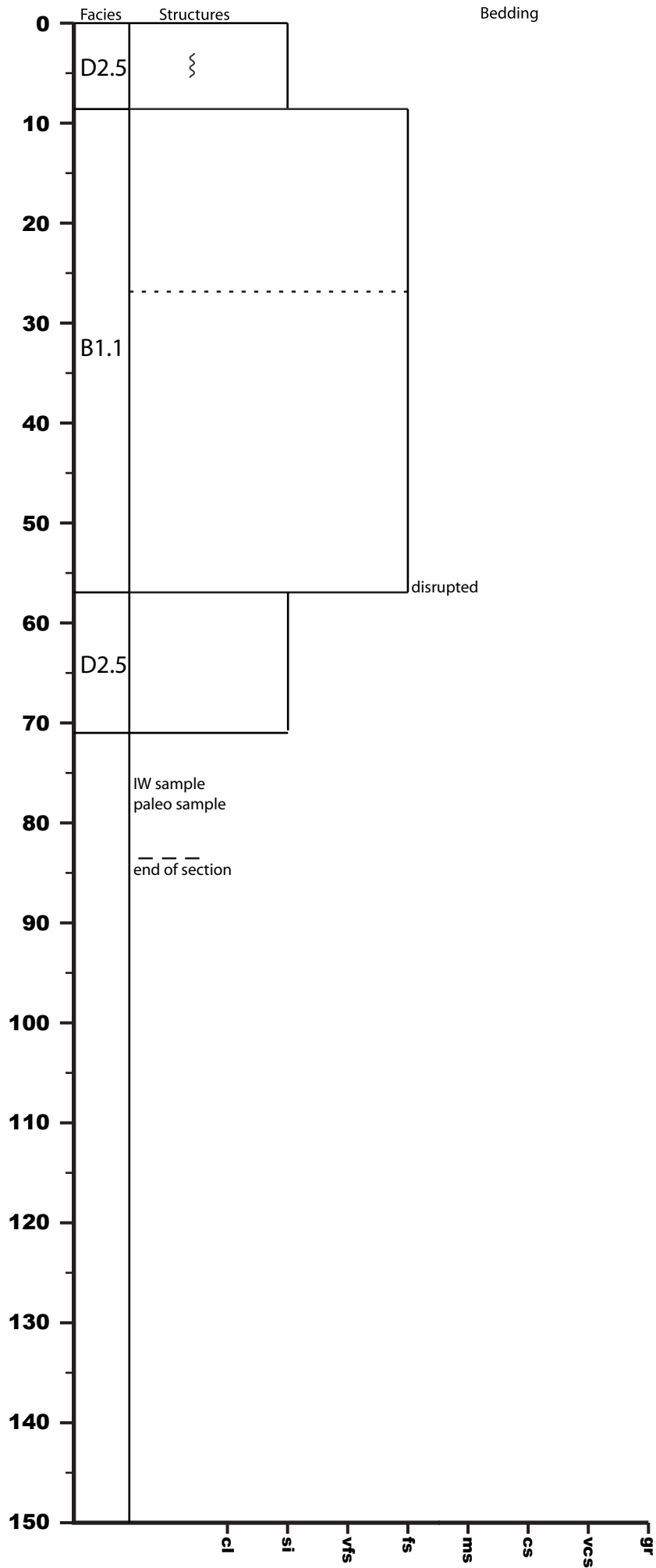

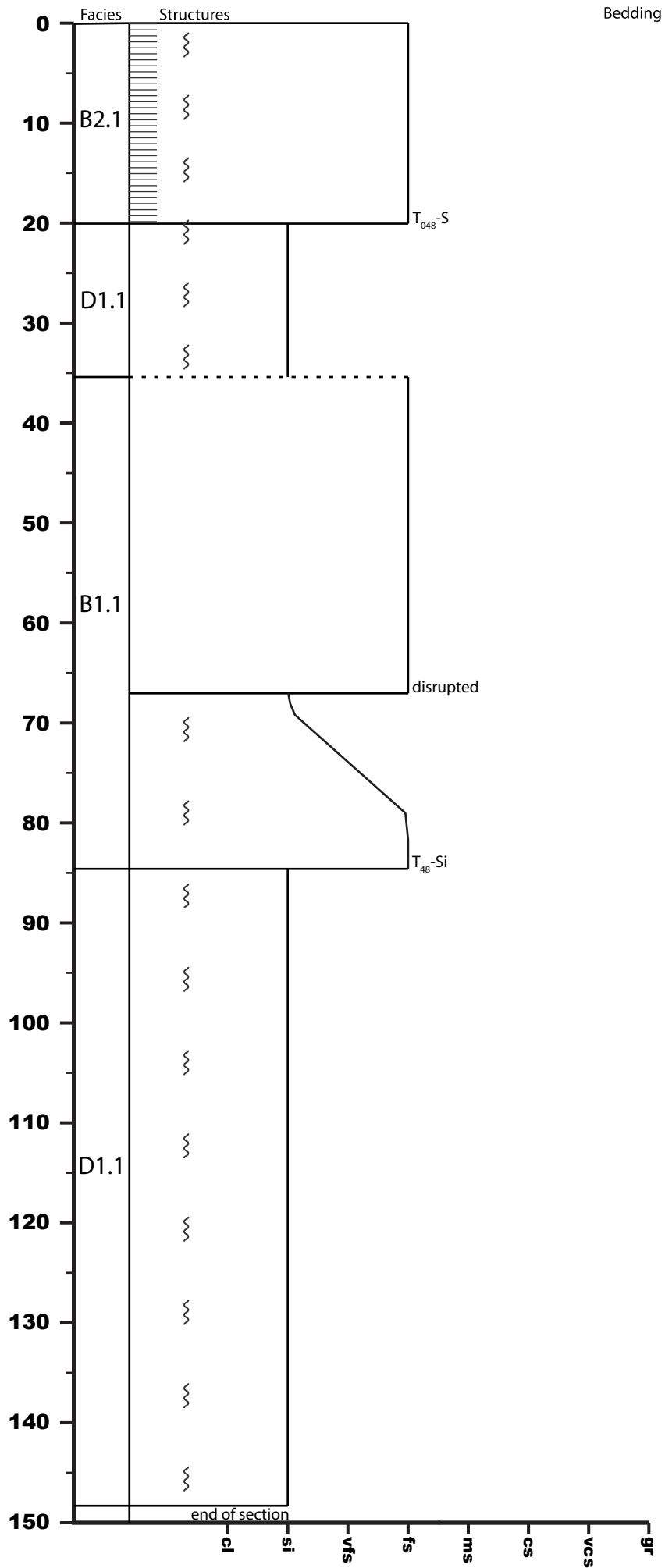

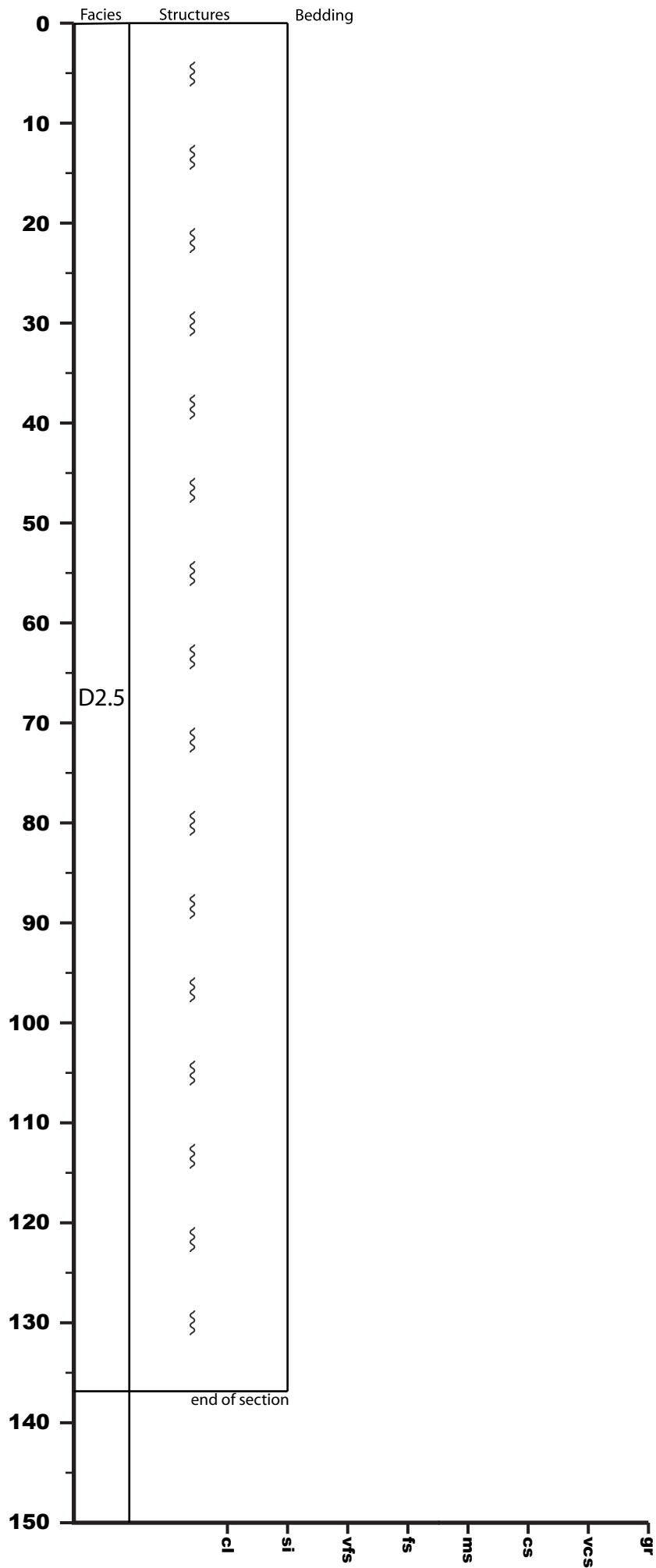

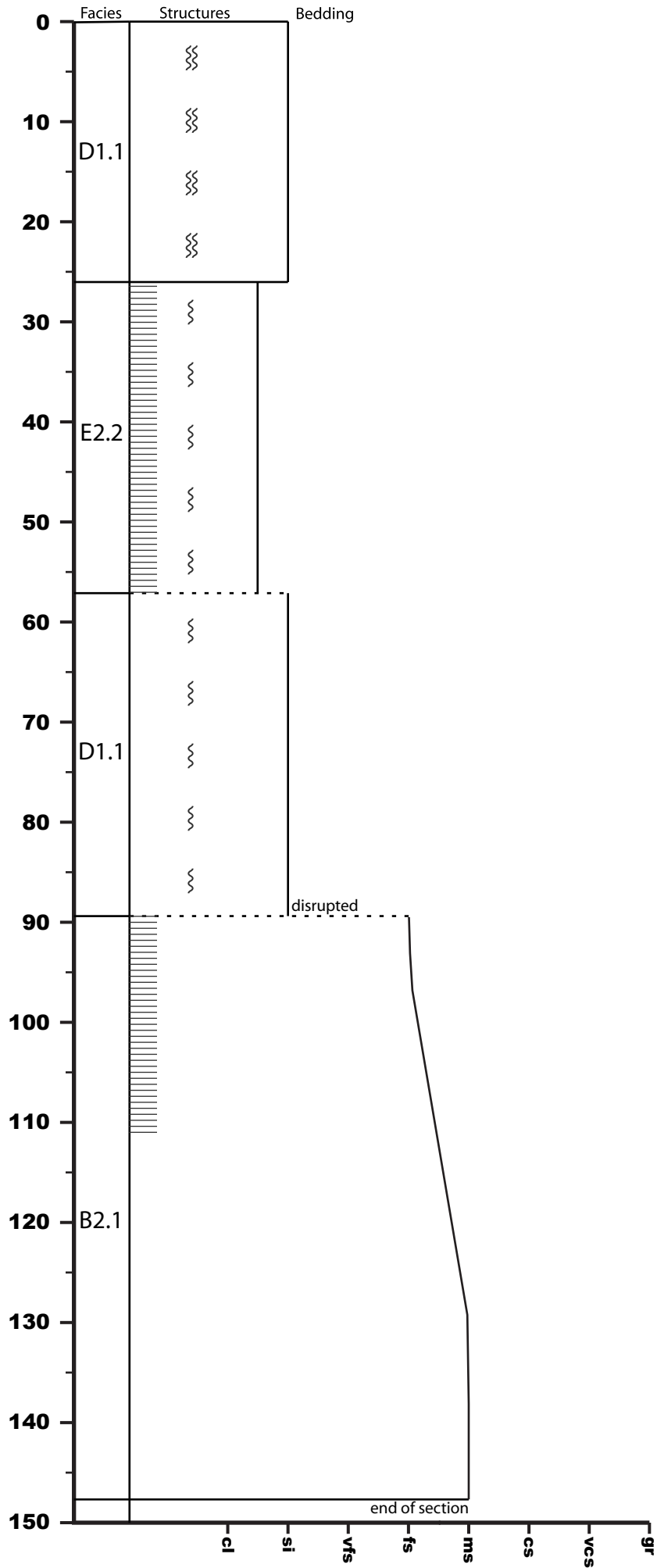



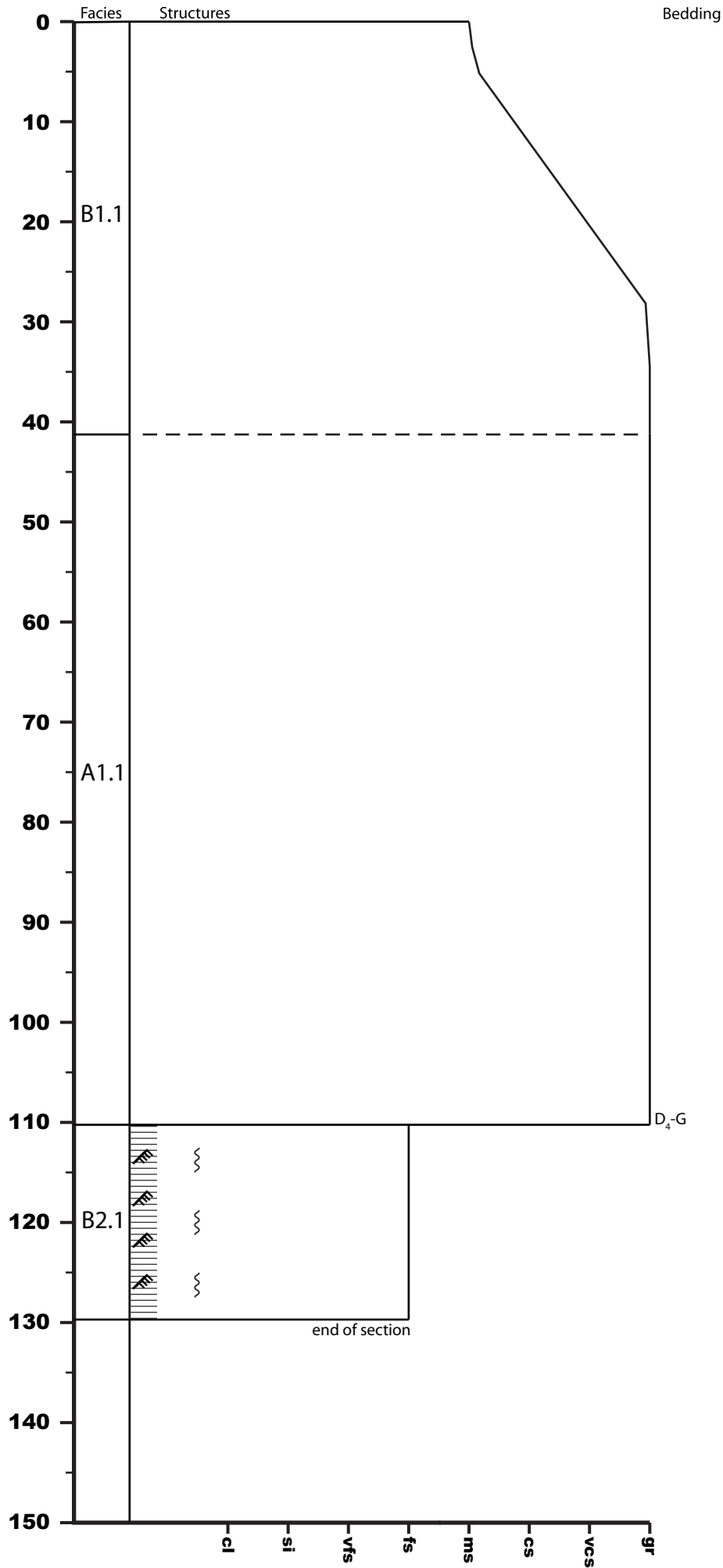

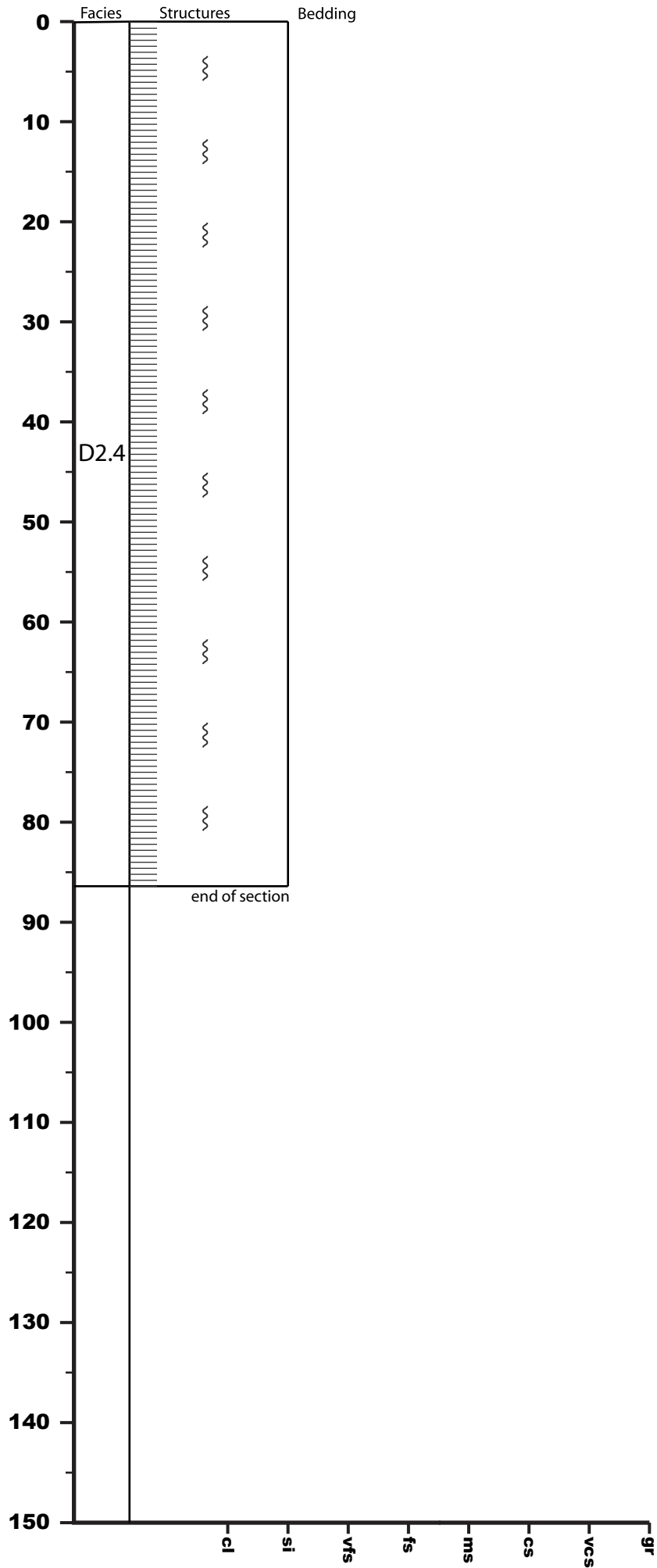

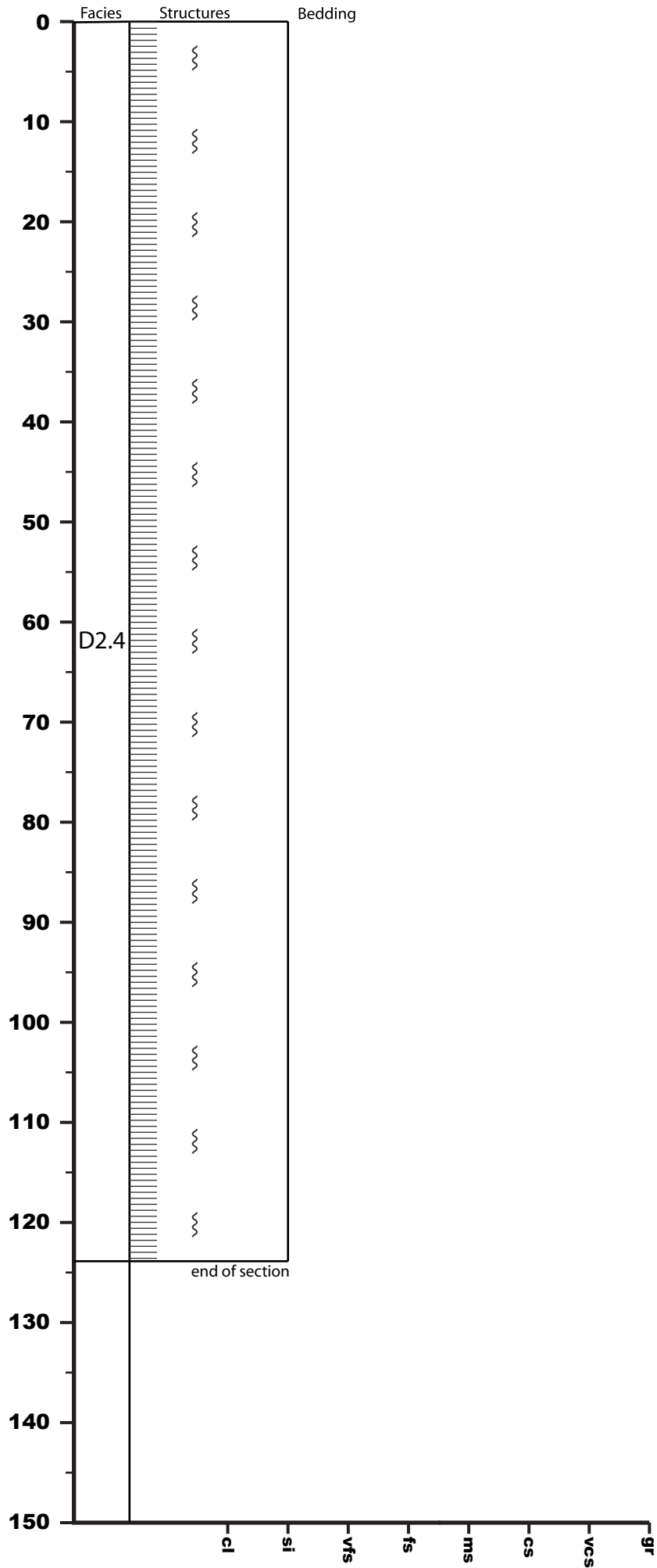

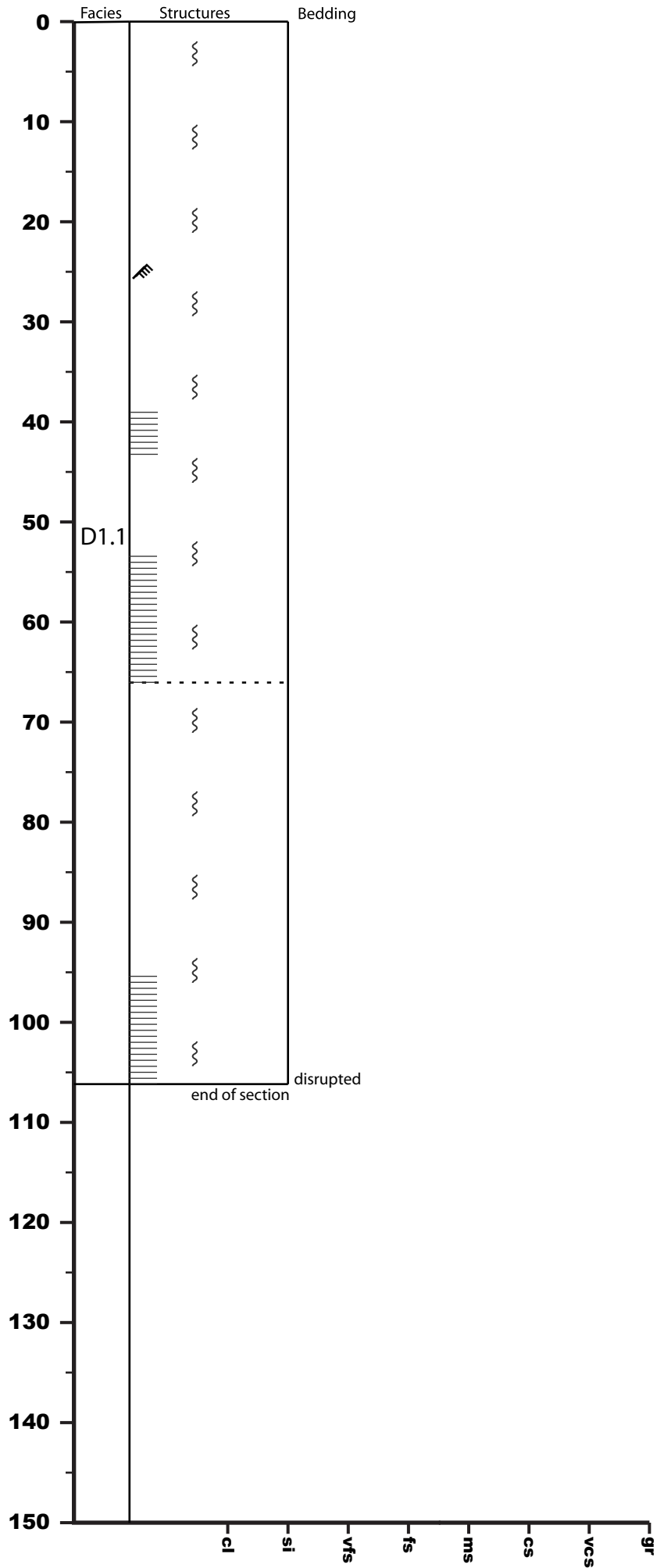

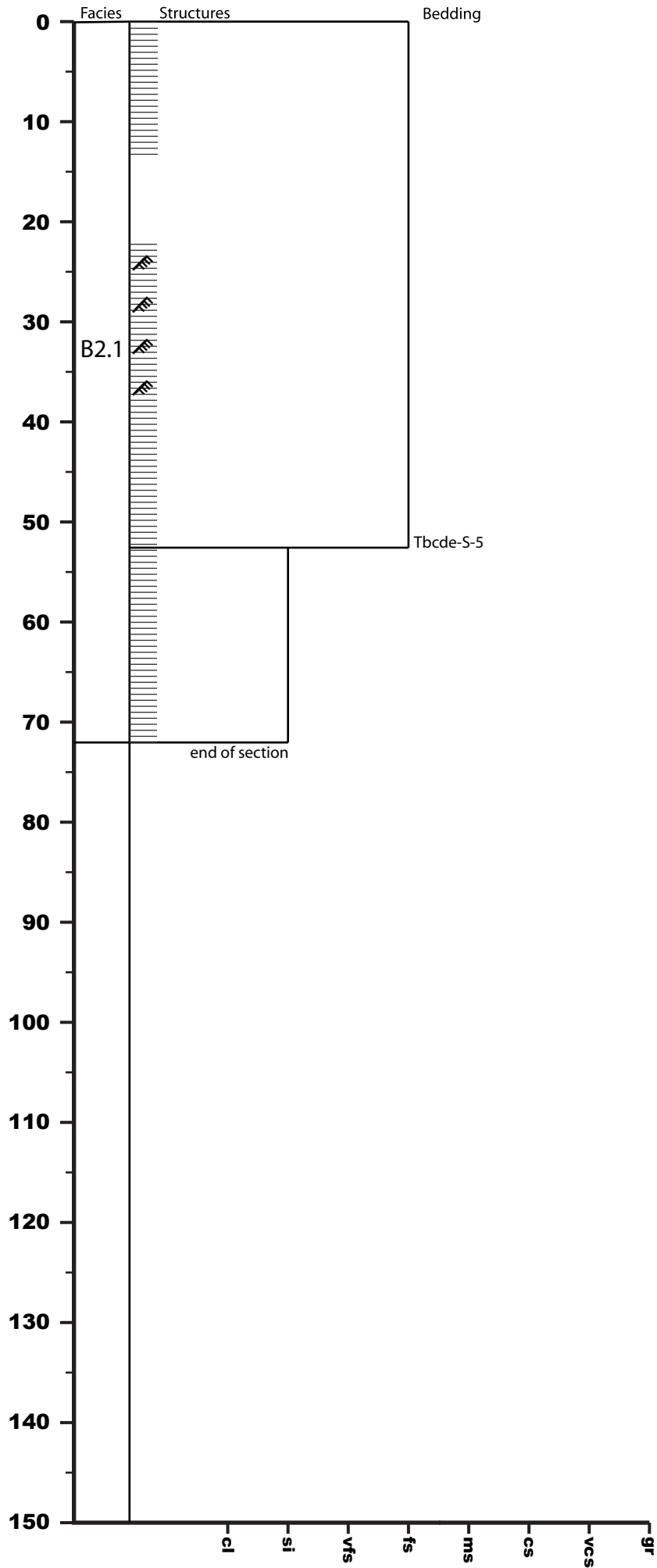

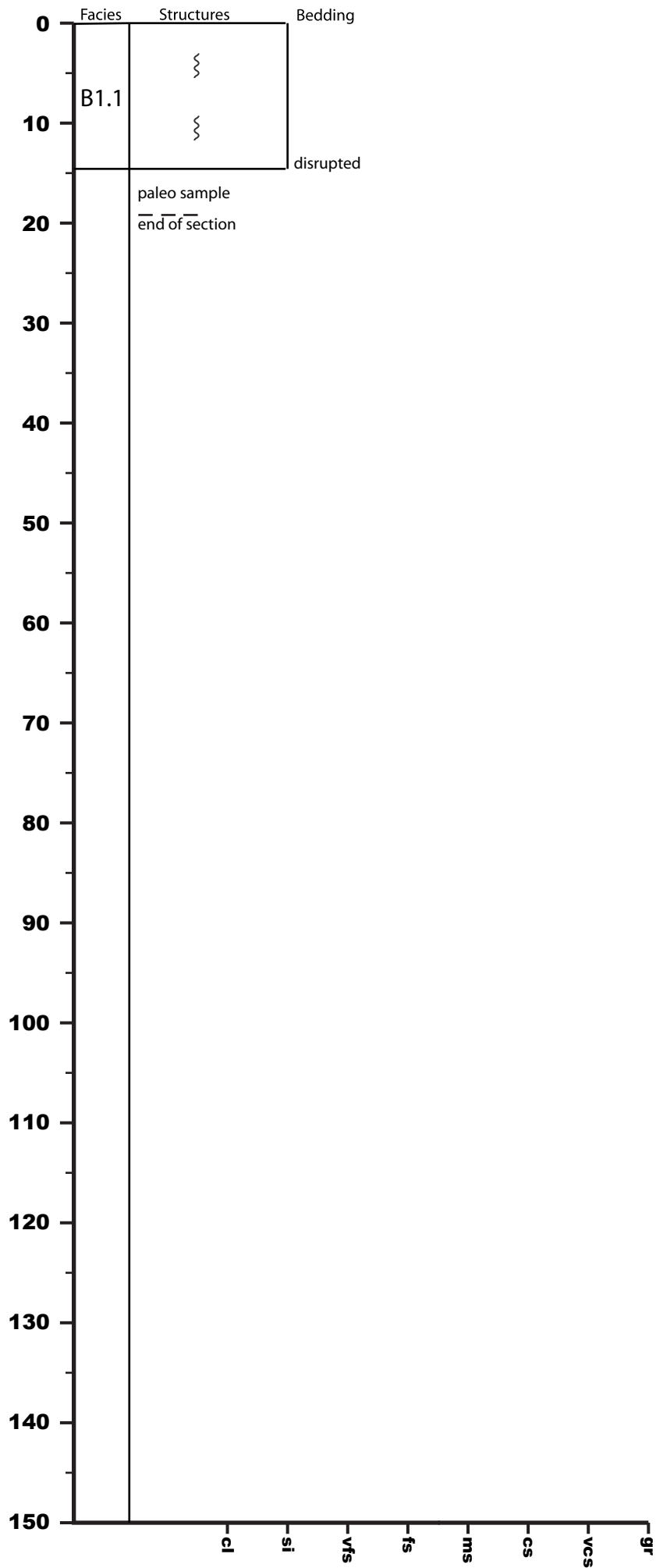

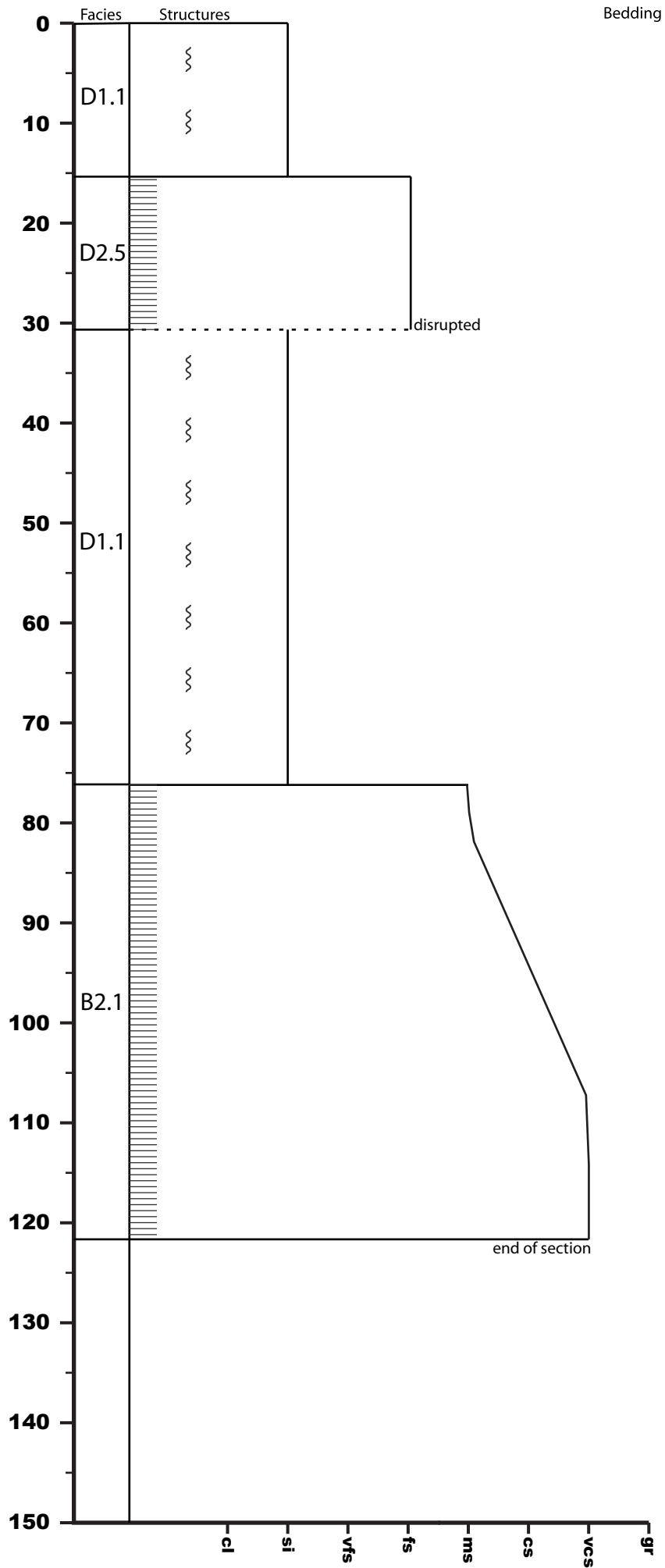

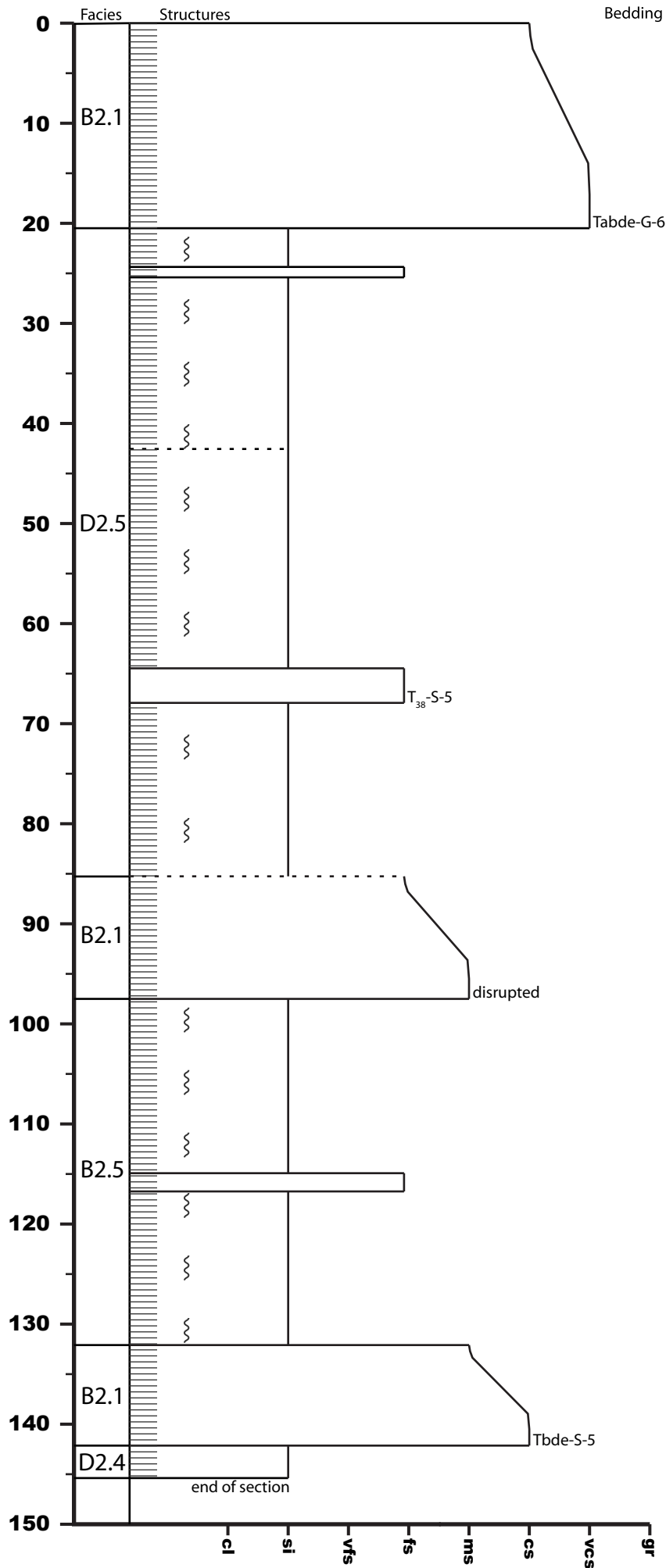



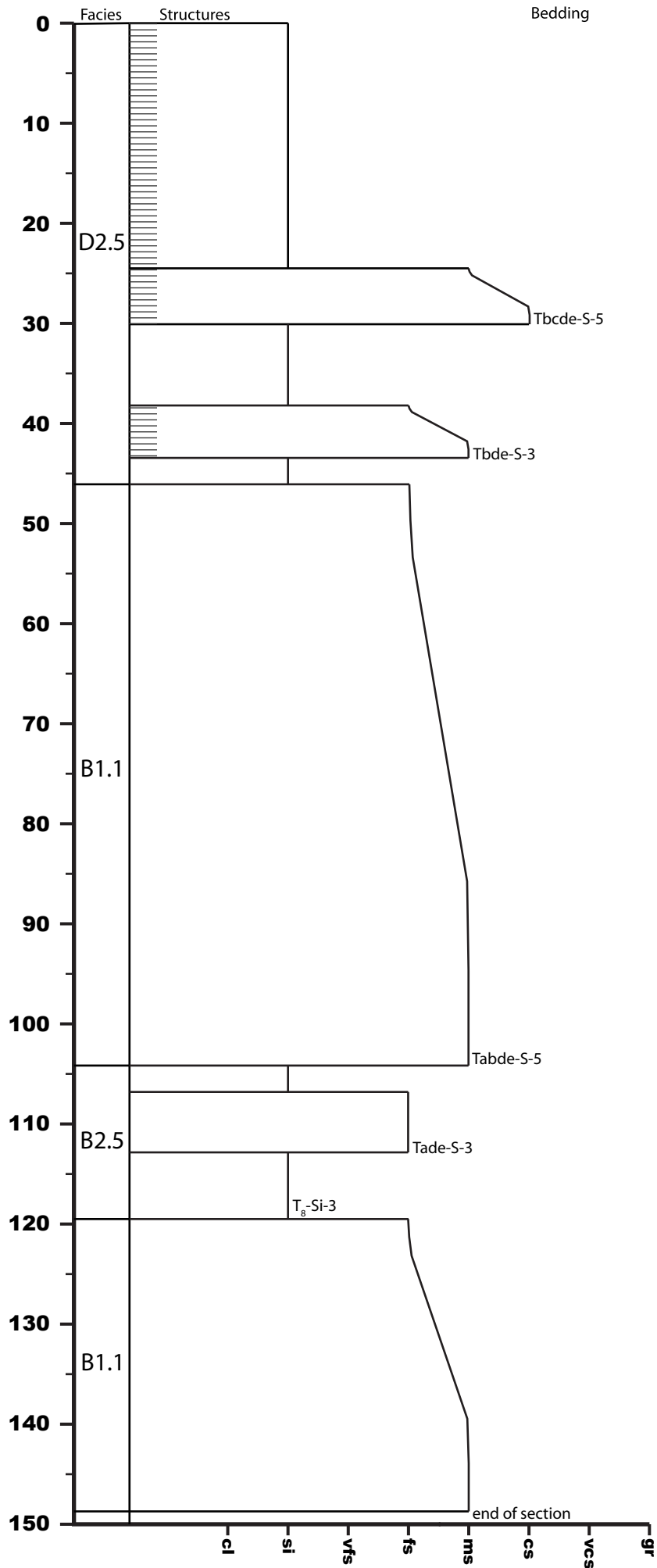

U1438D-61R-4

785.59 - 787.09 mbsf

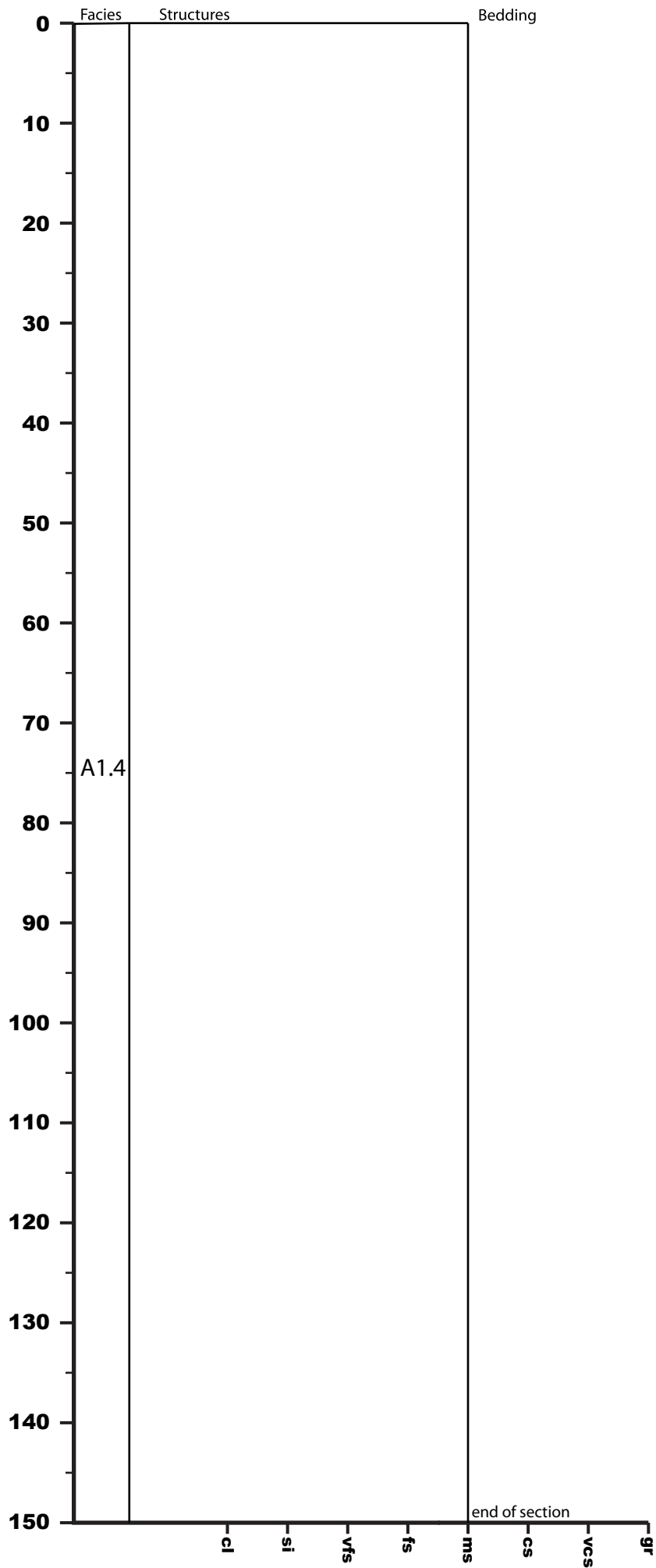

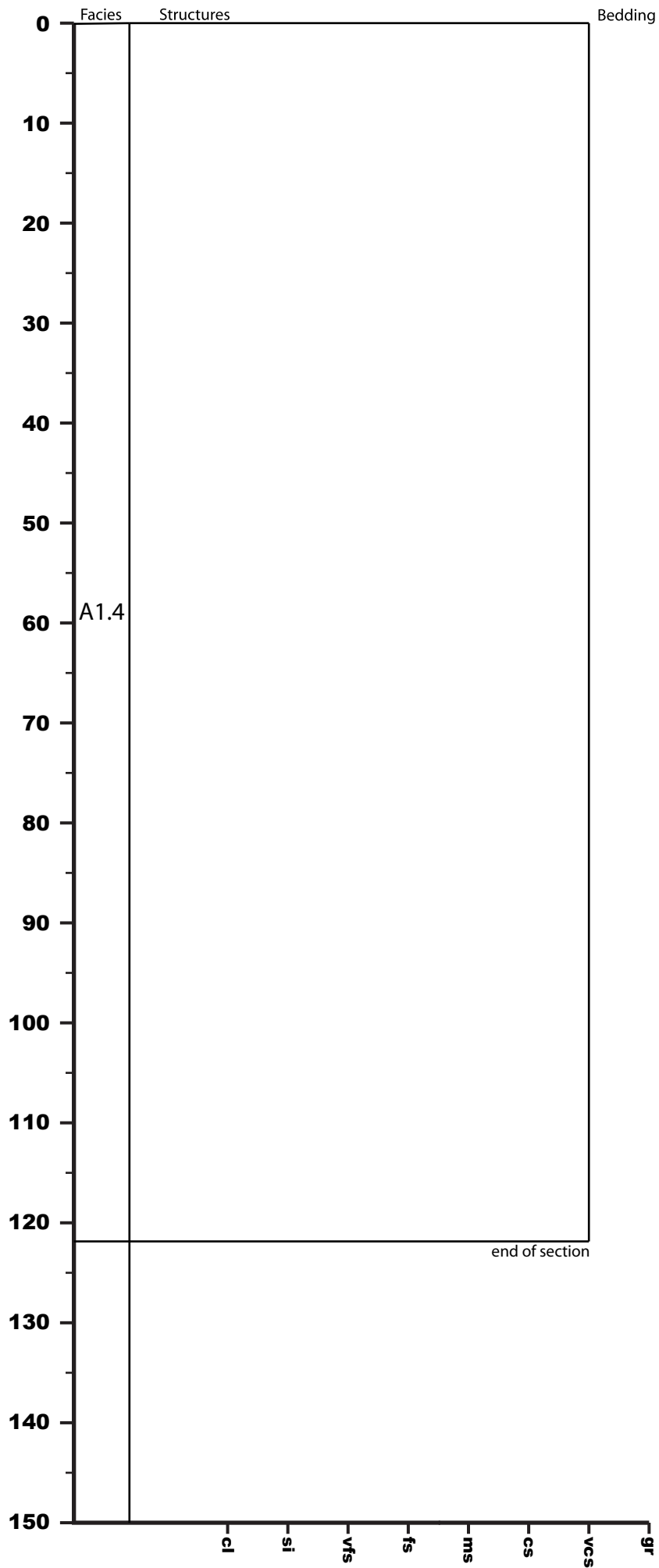

U1438D-61R-6

788.31 - 789.81 mbsf

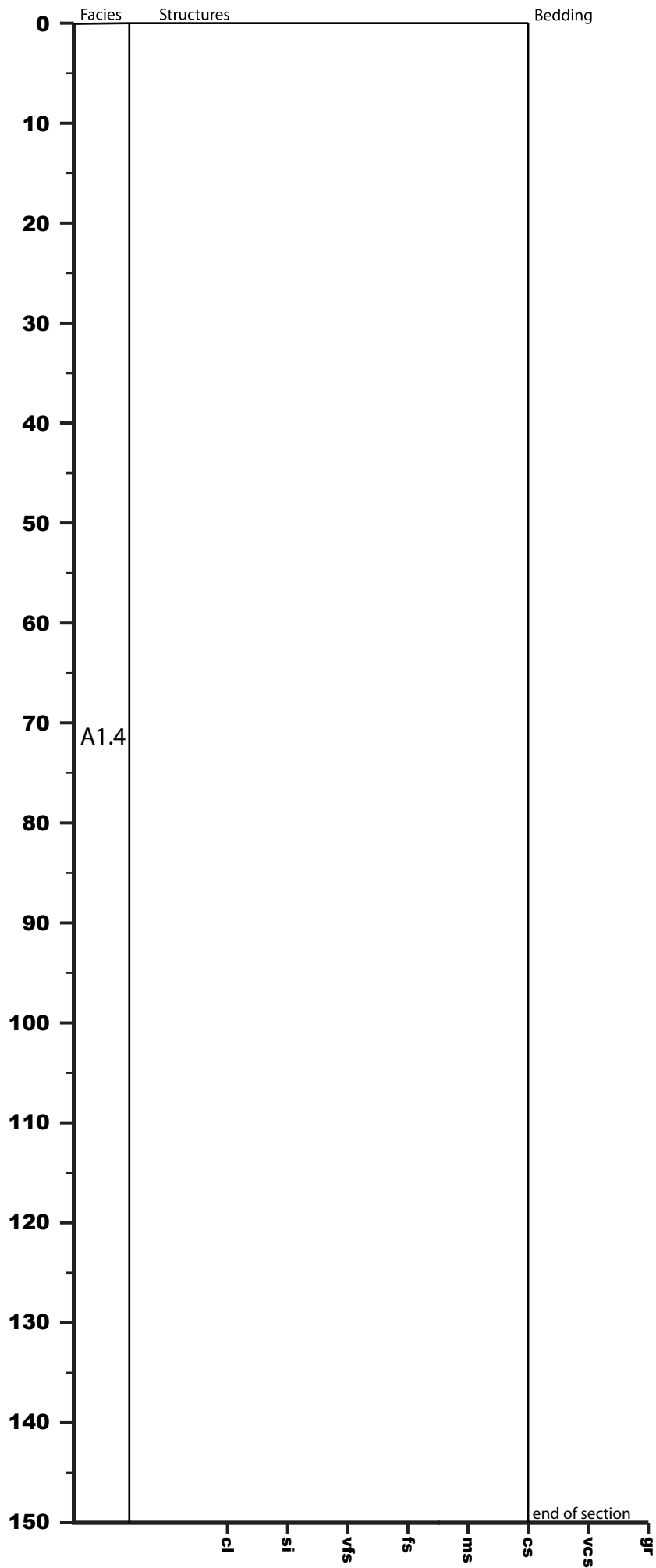

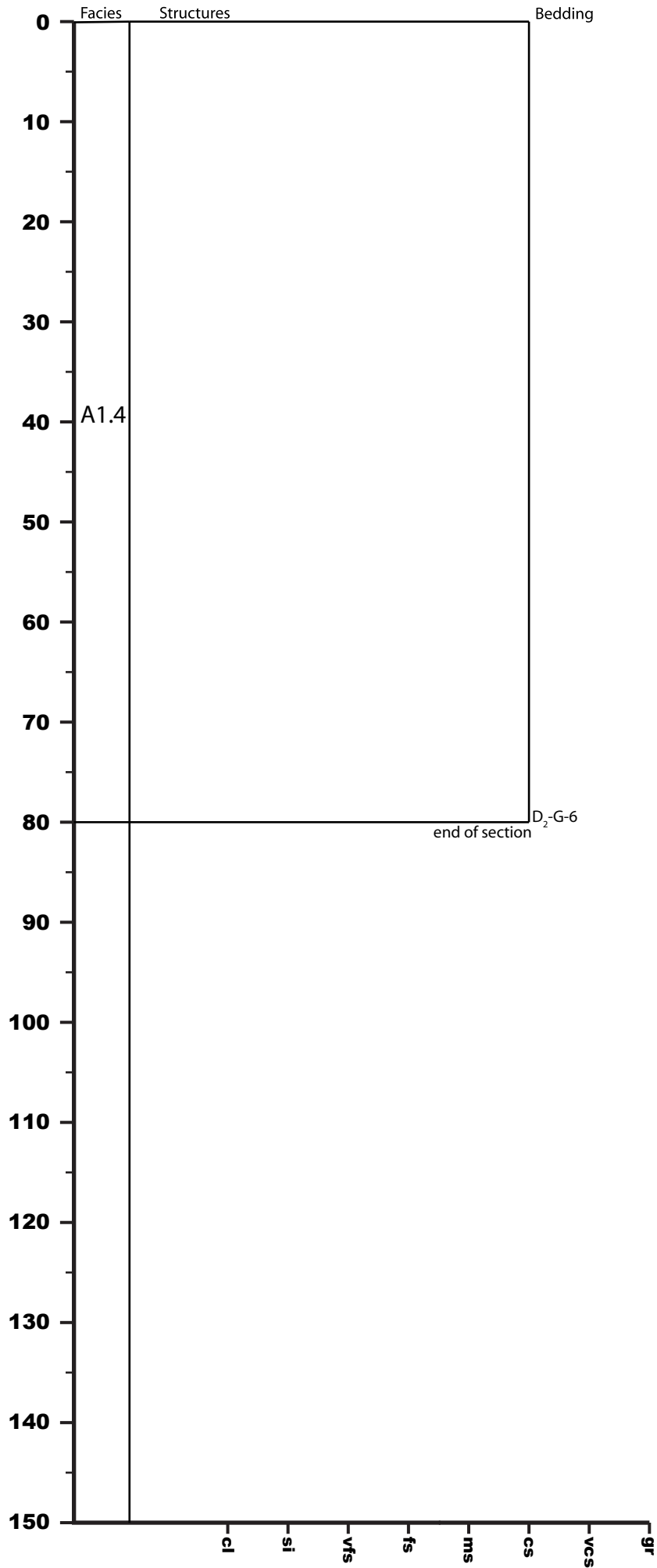

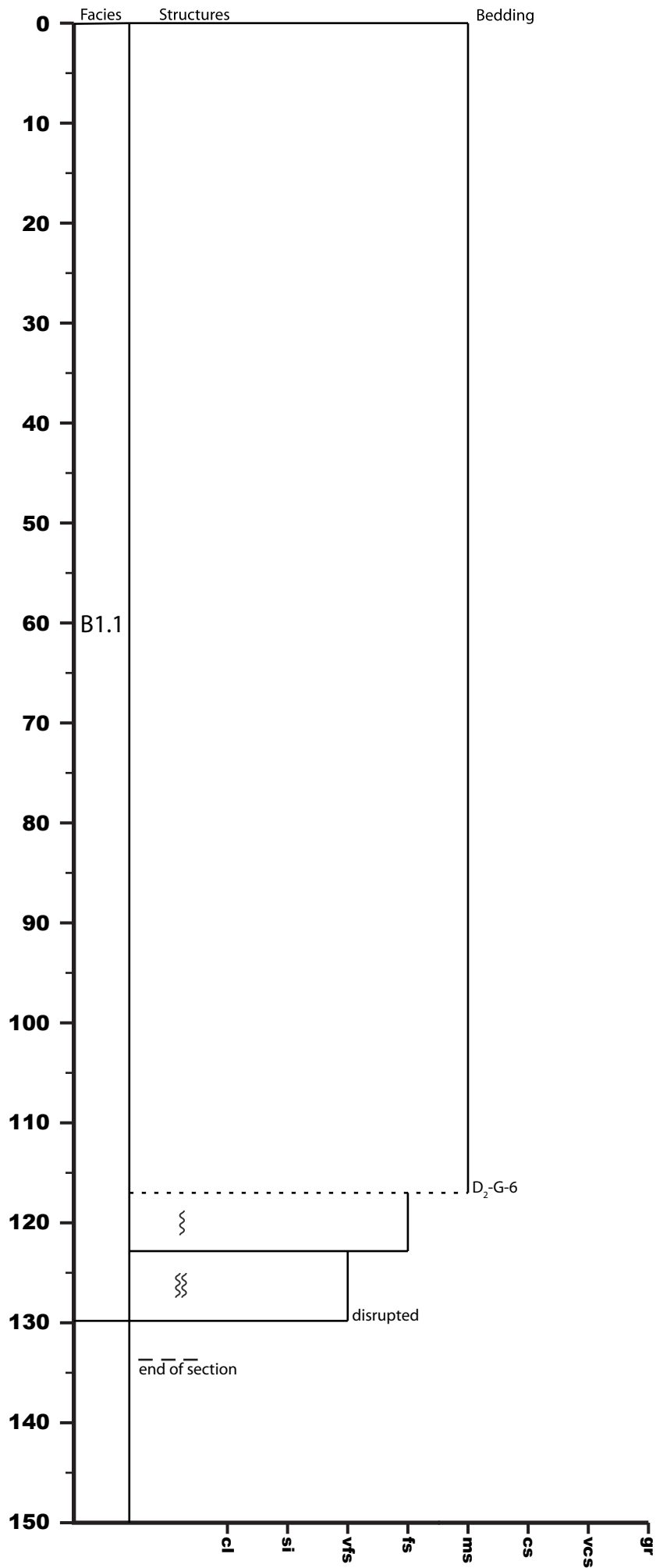

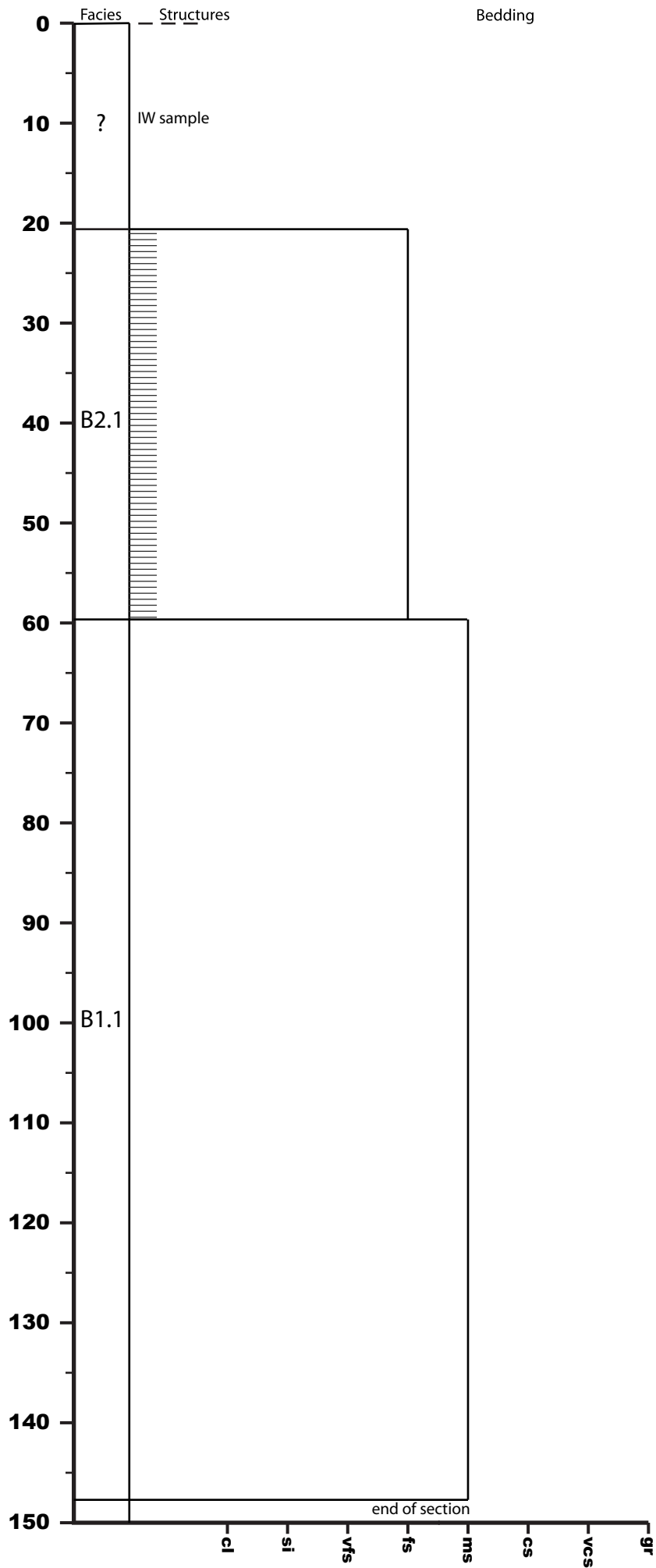

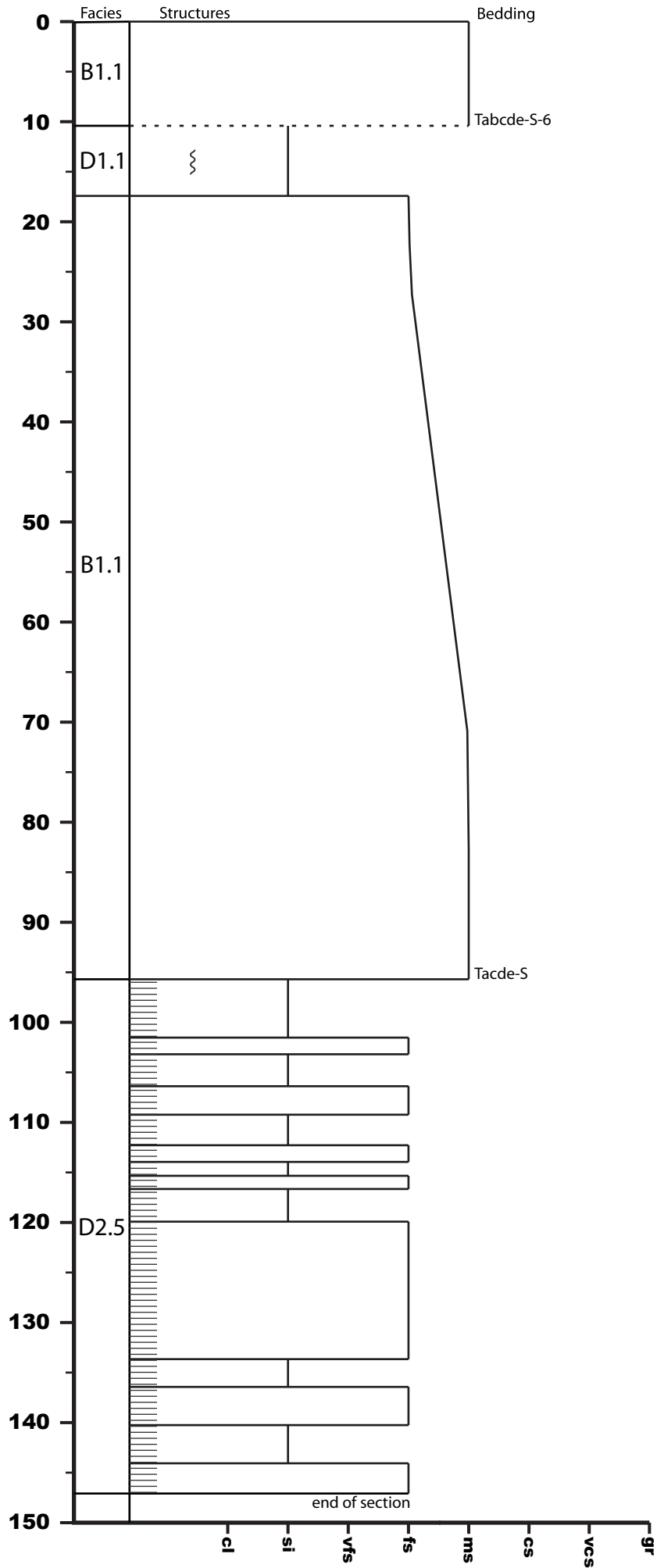



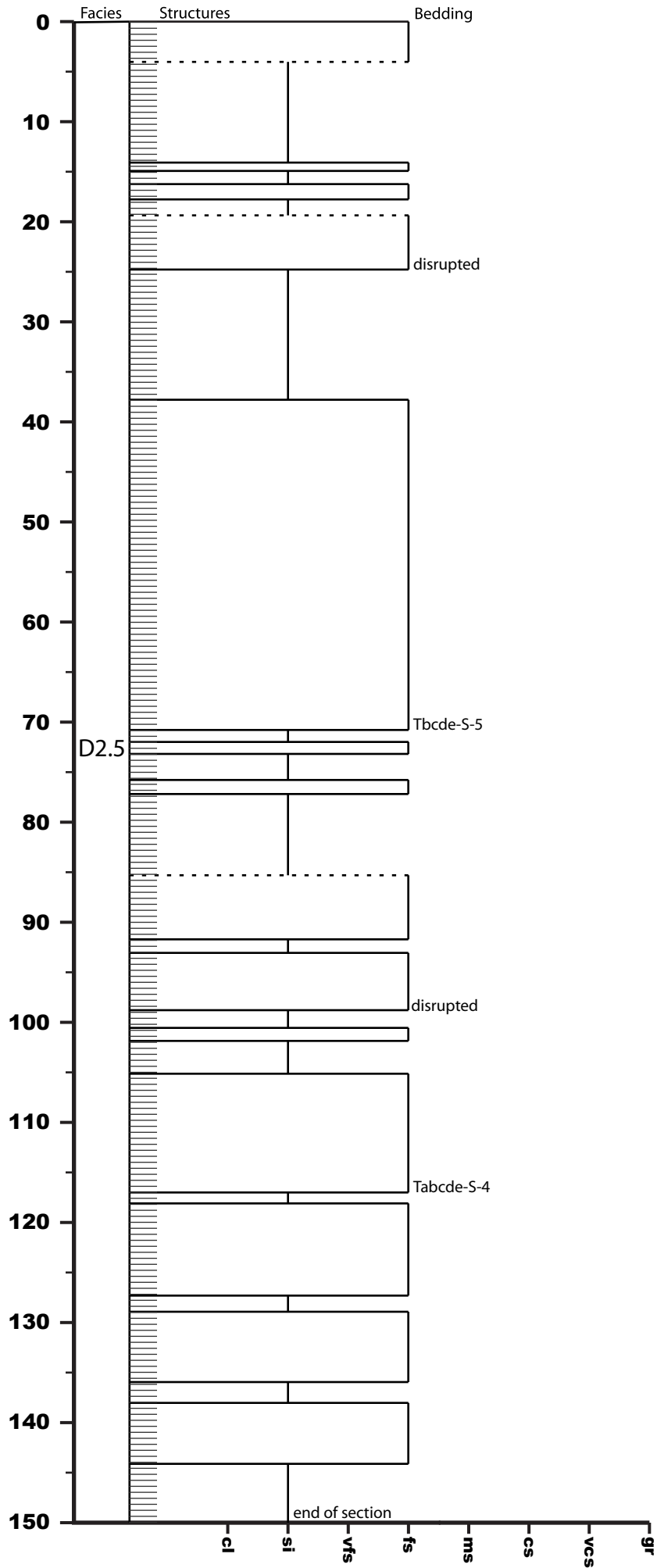

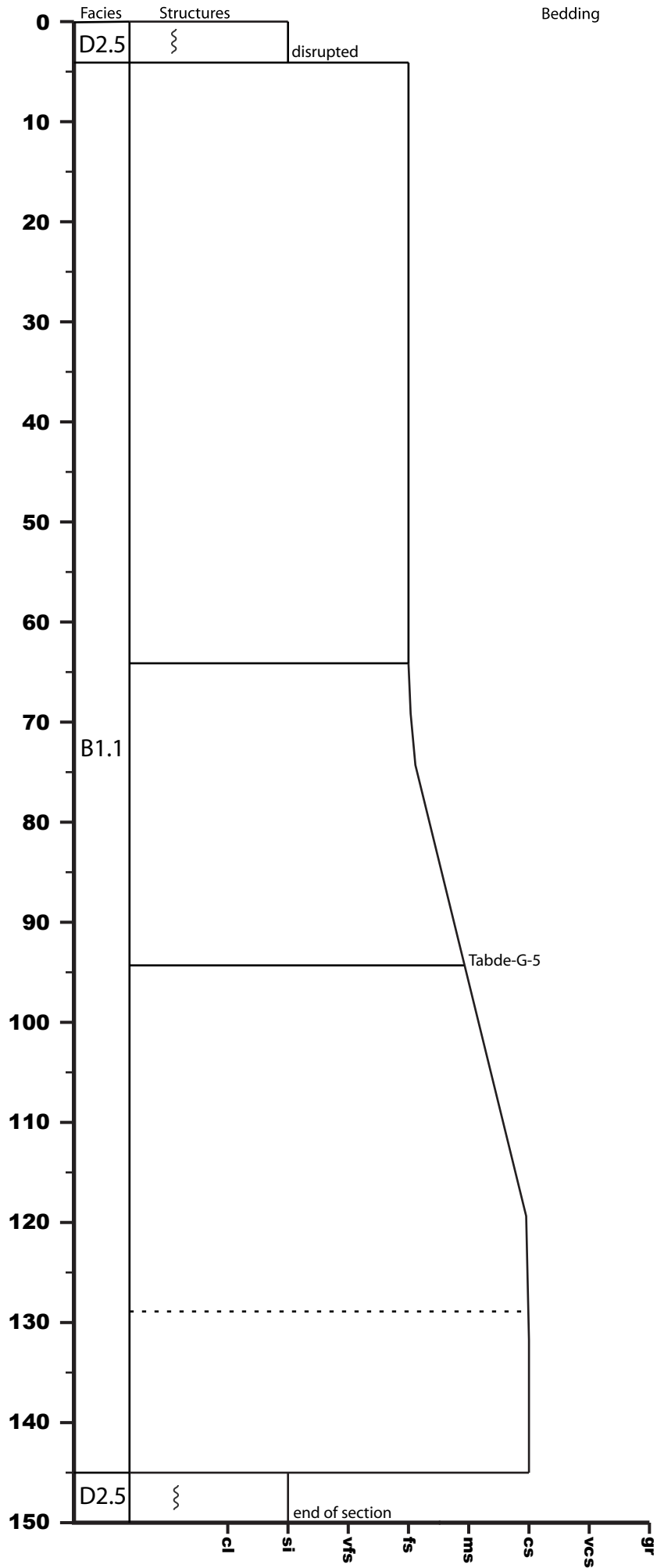

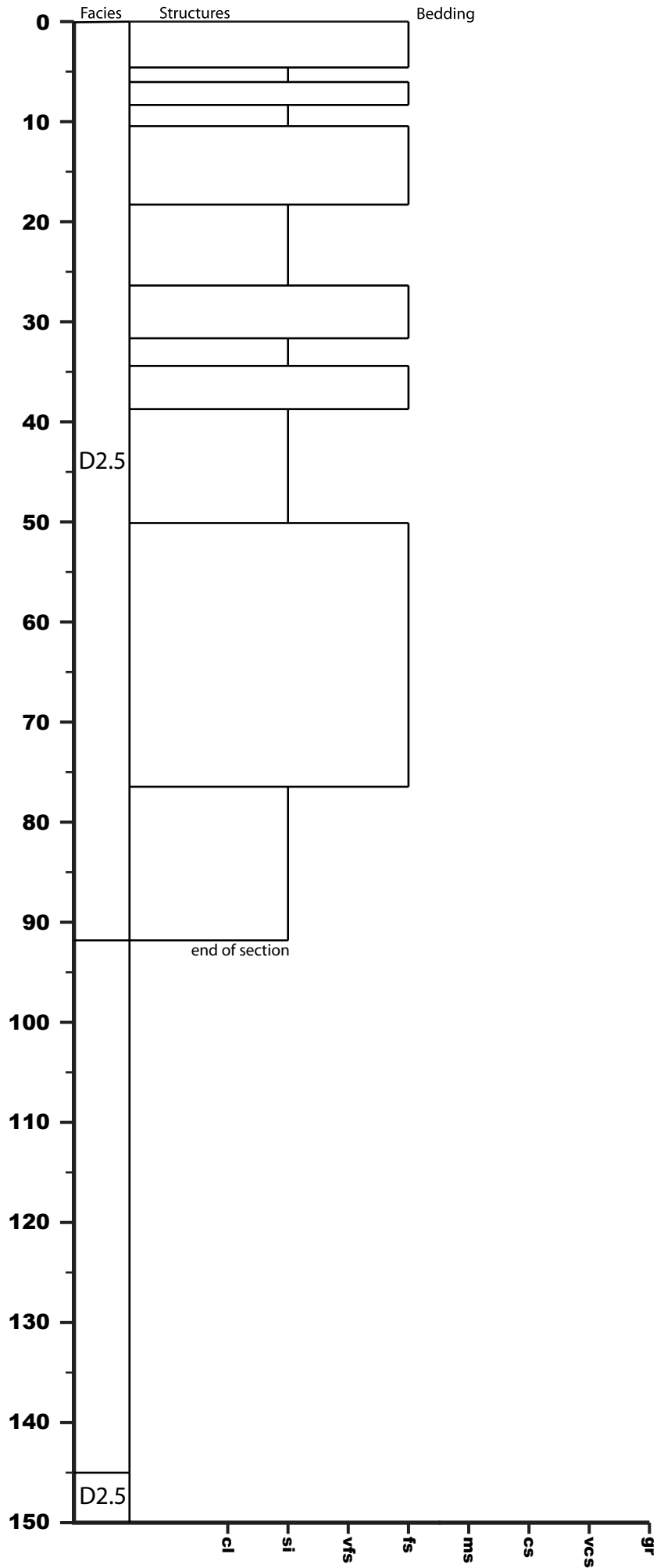

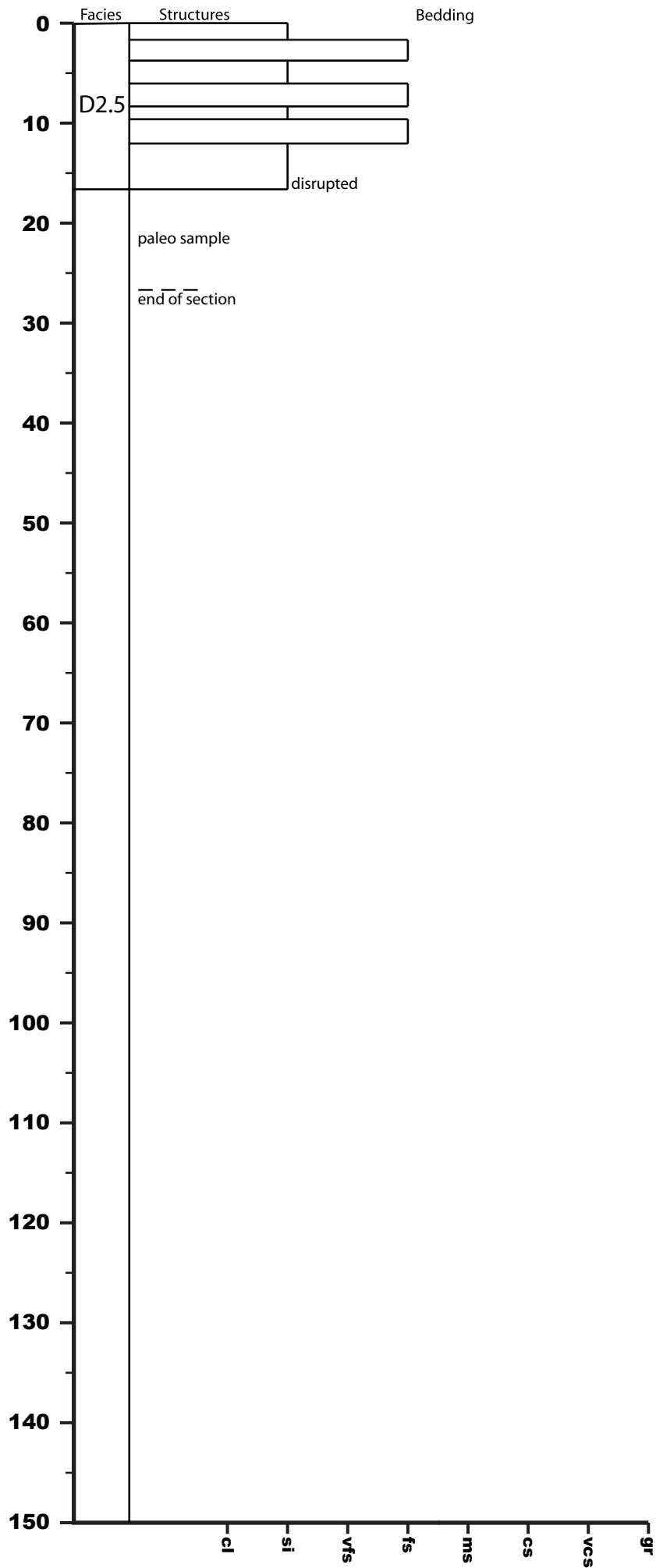

U1438D-63R-1

800.8 - 802.3 mbsf

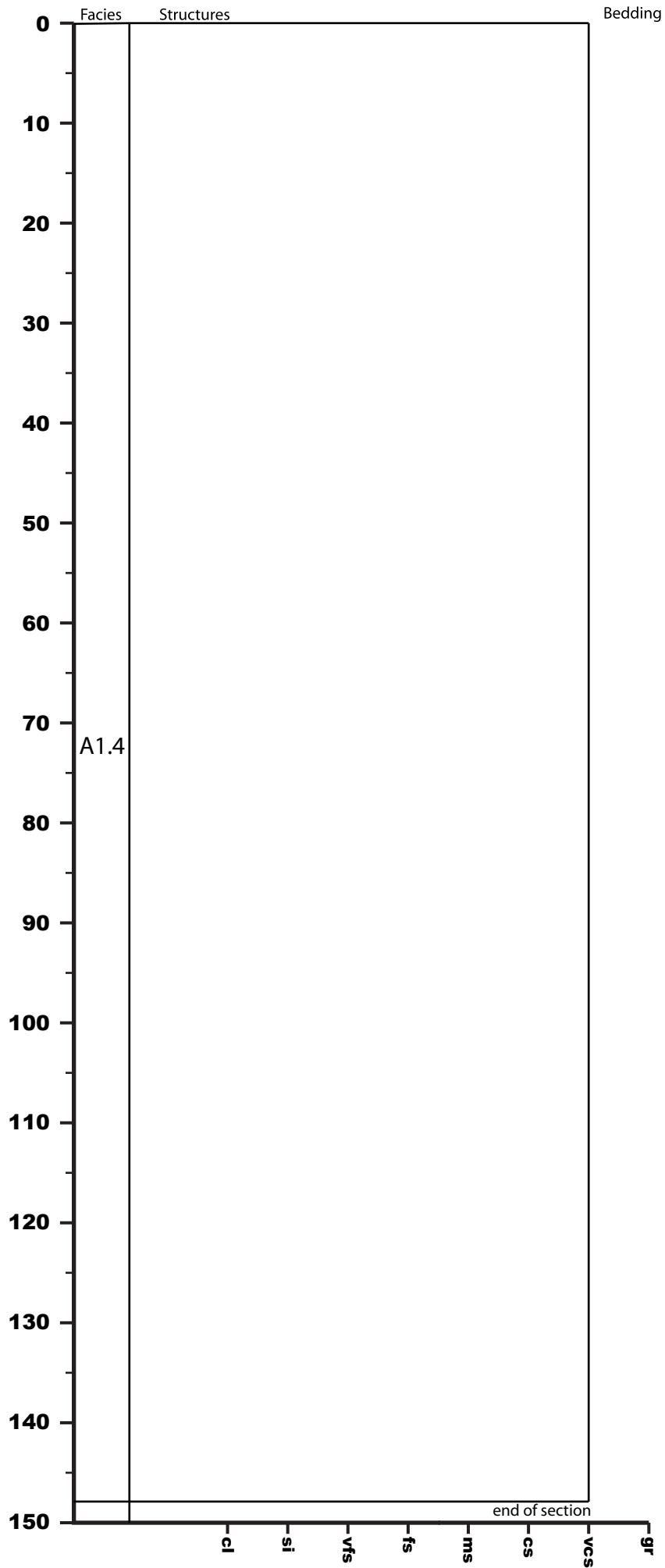

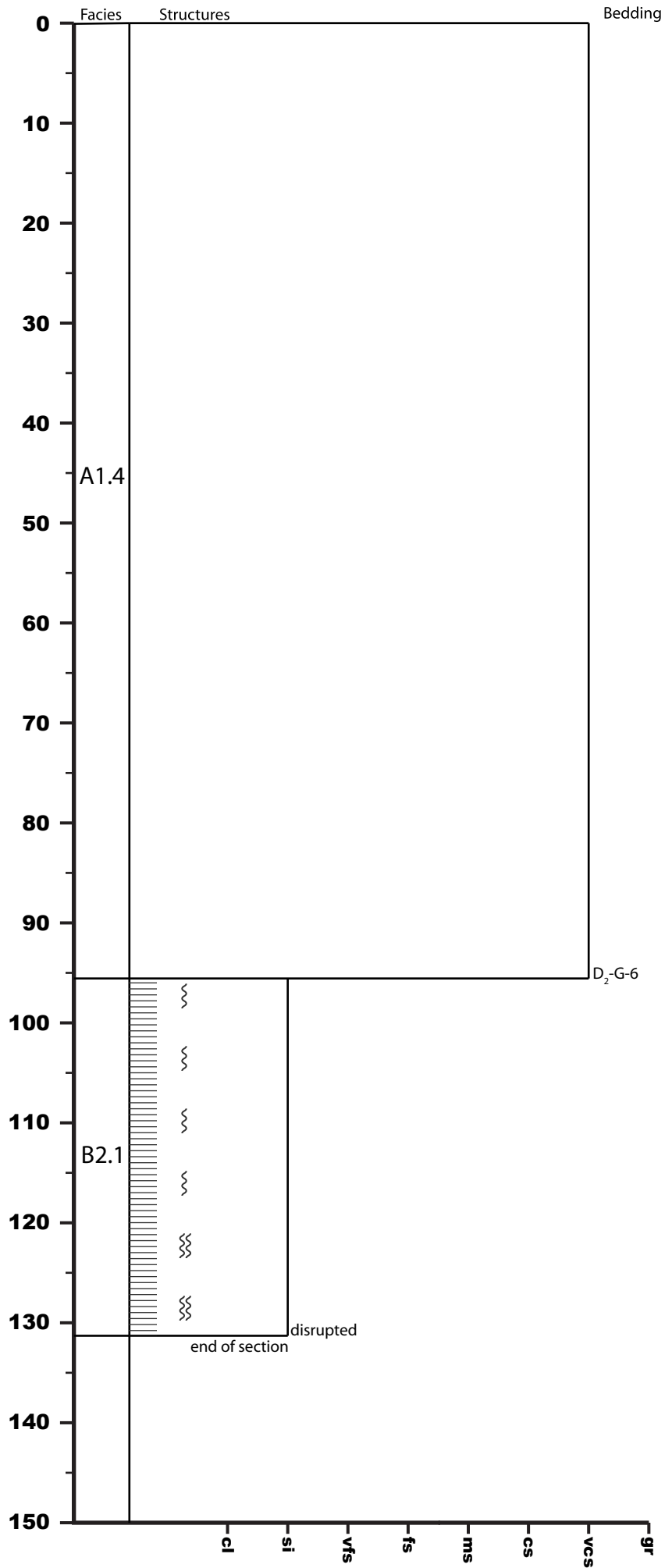

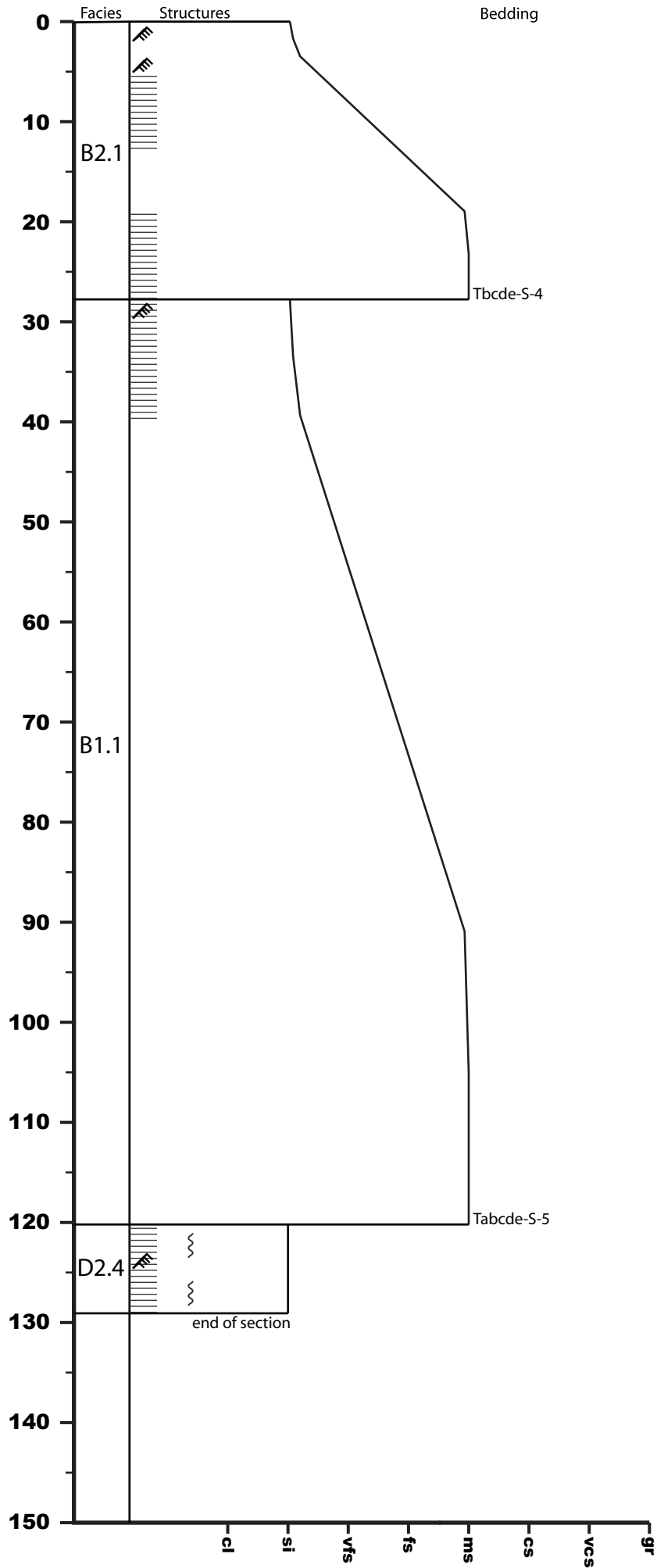

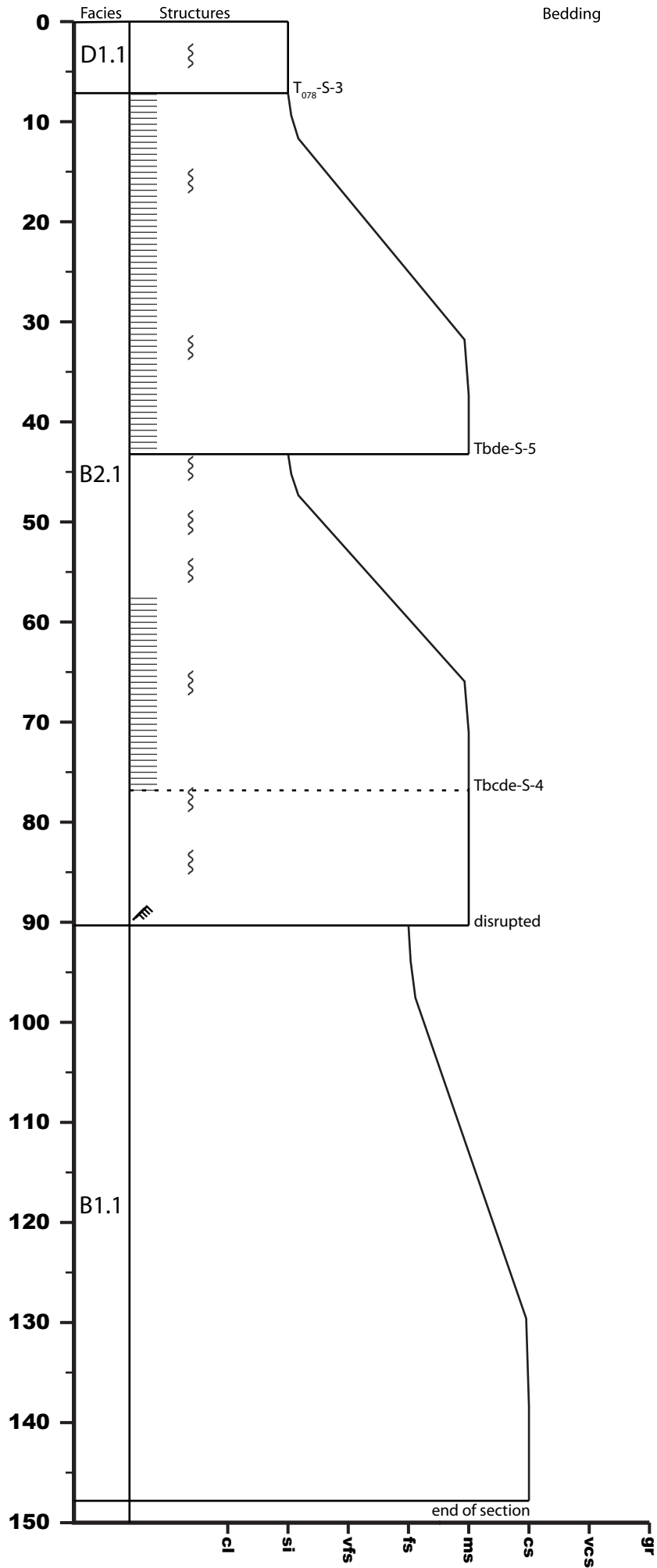



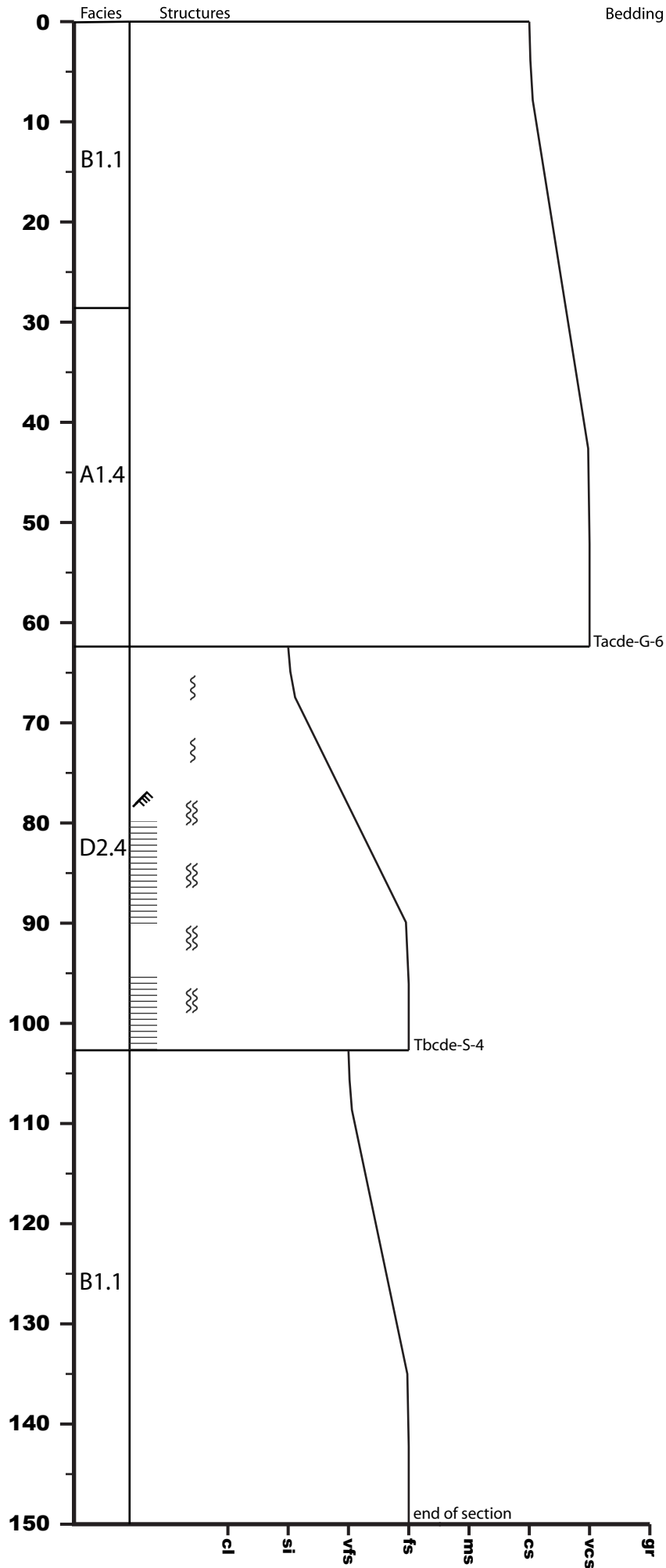

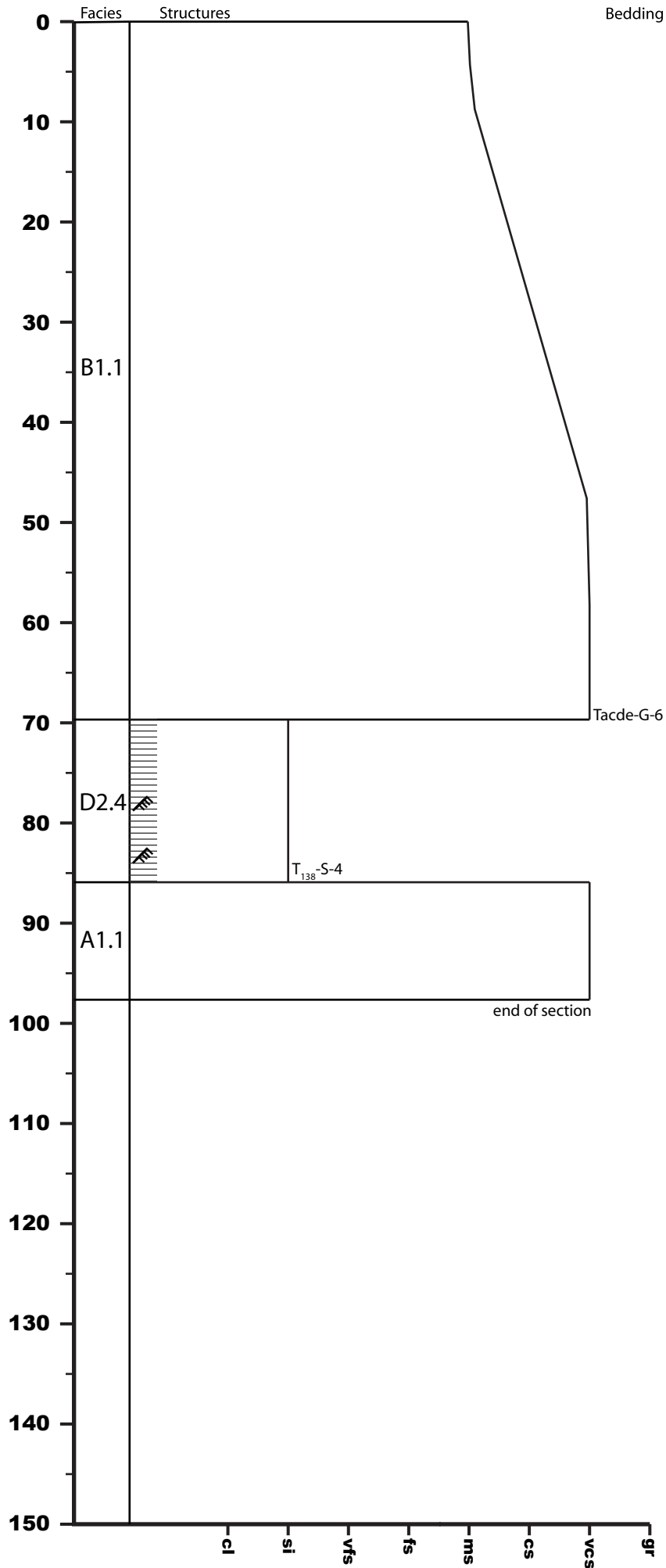

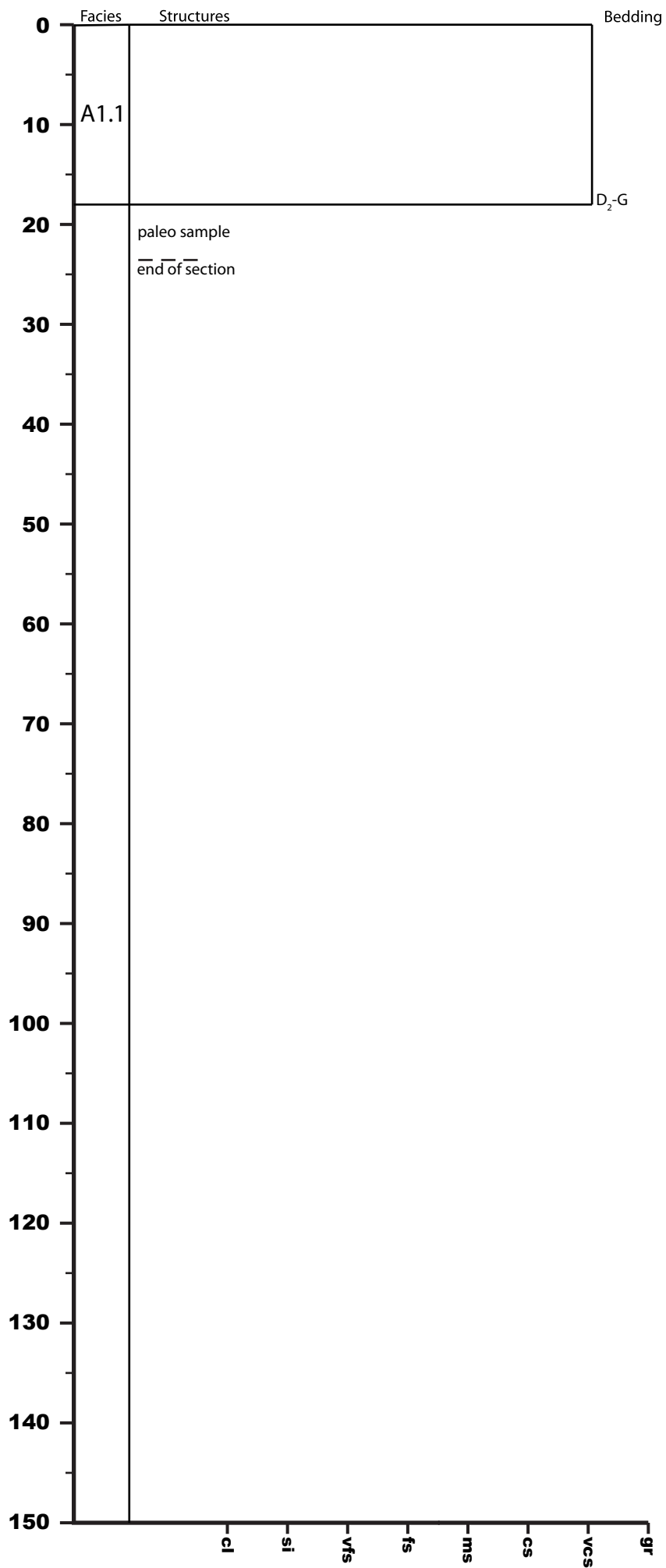

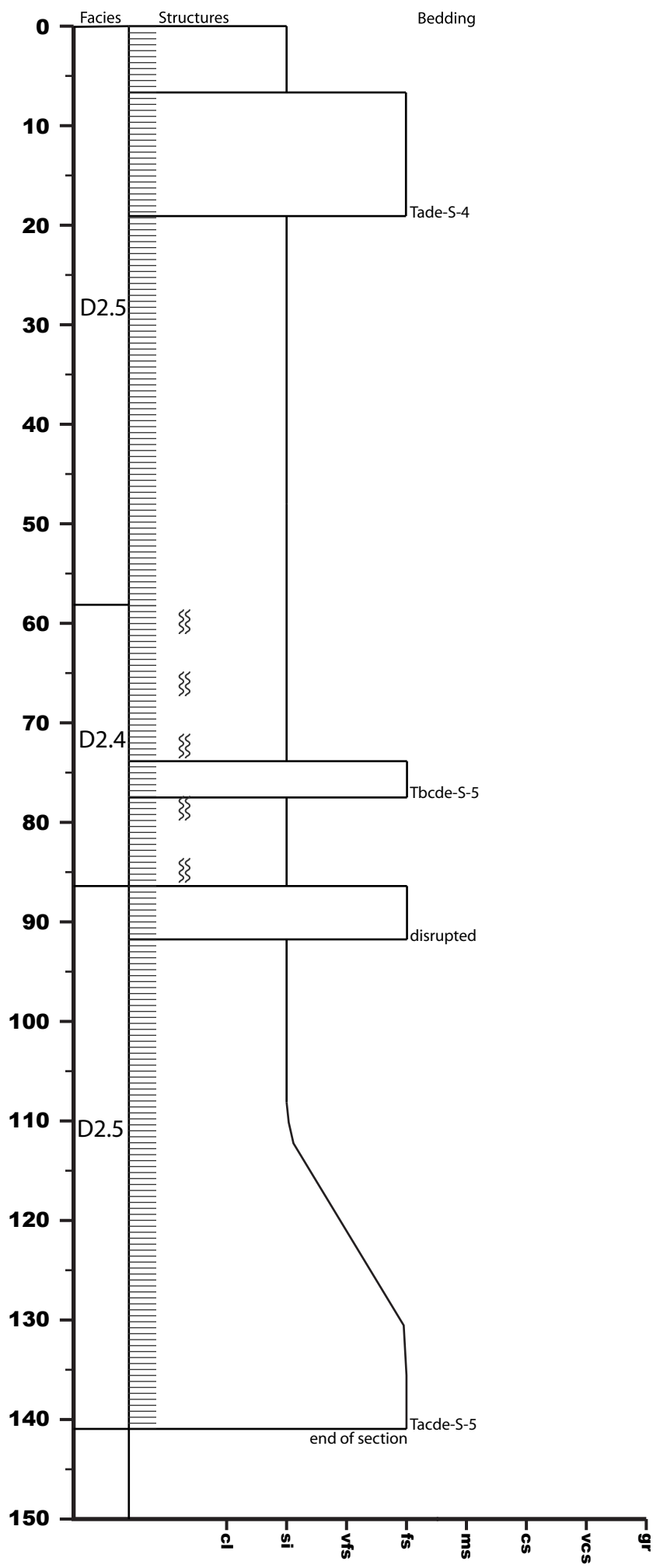

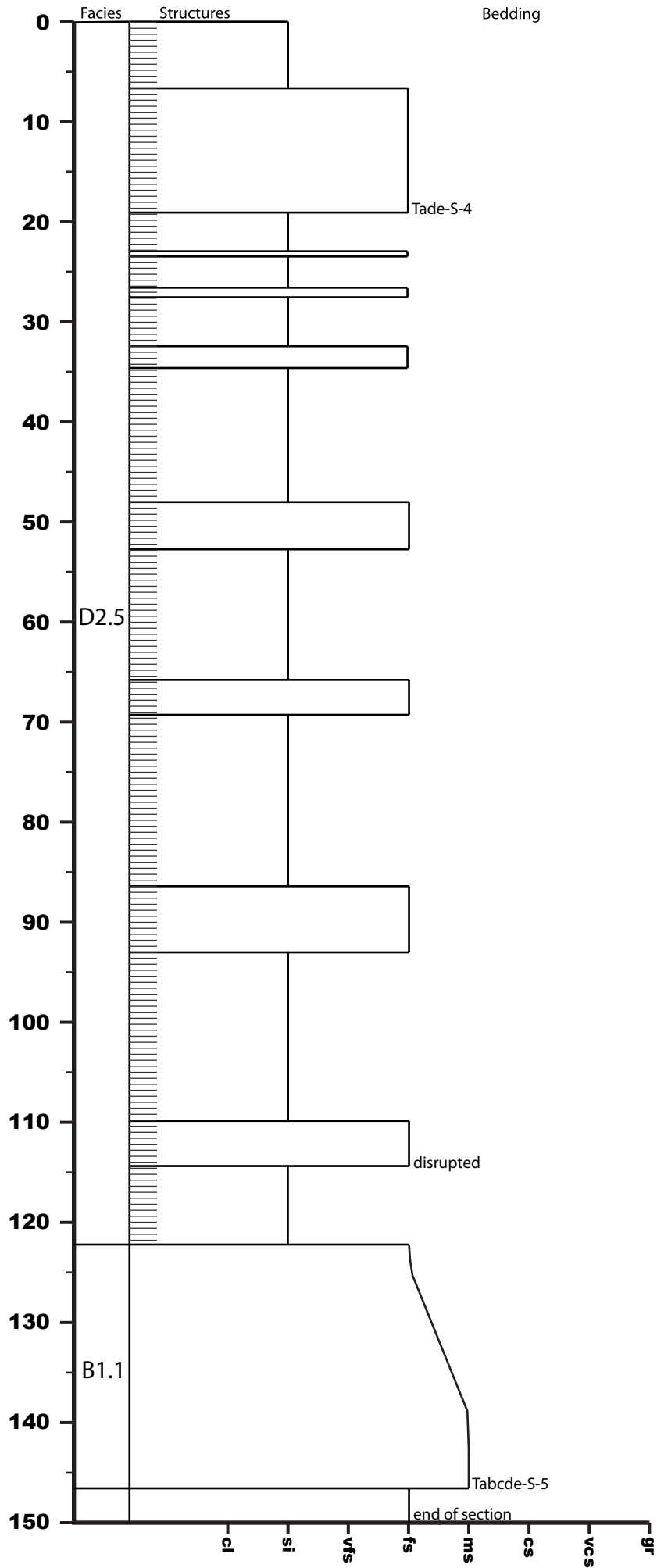

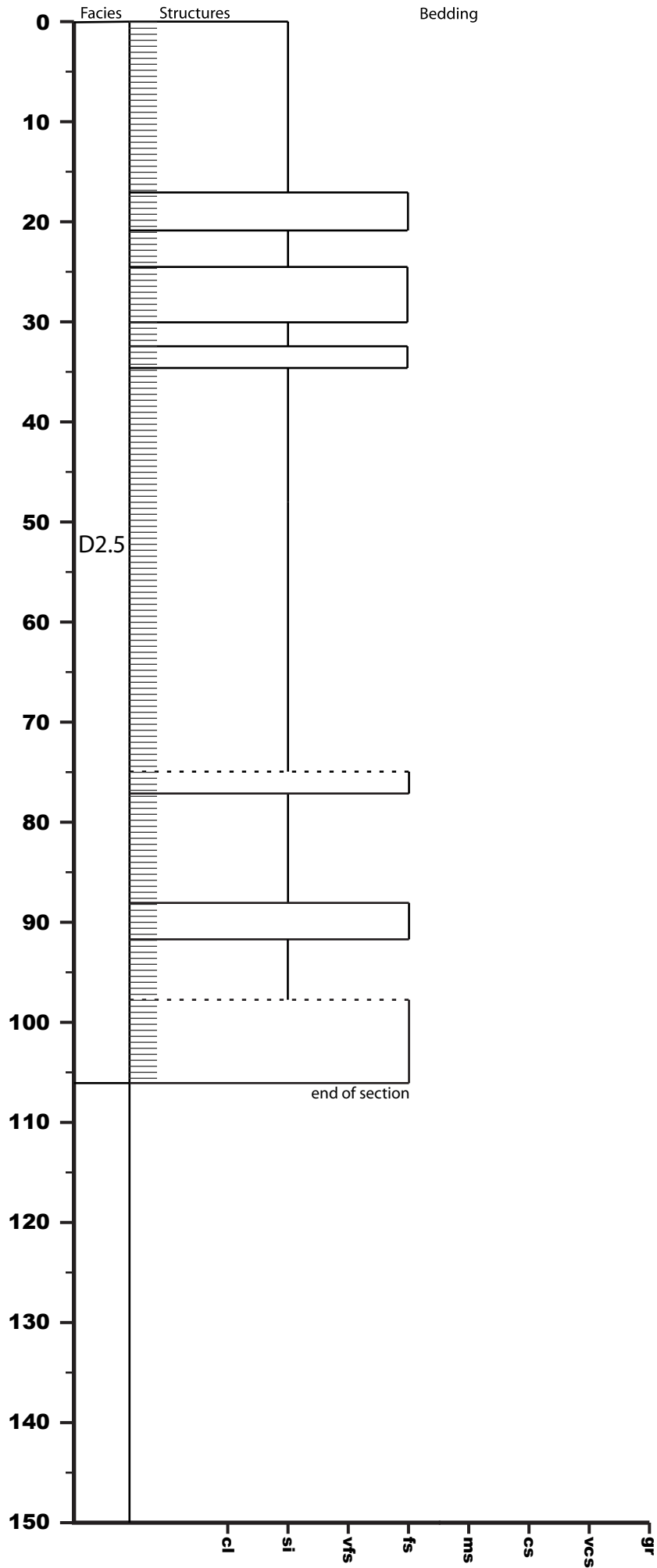

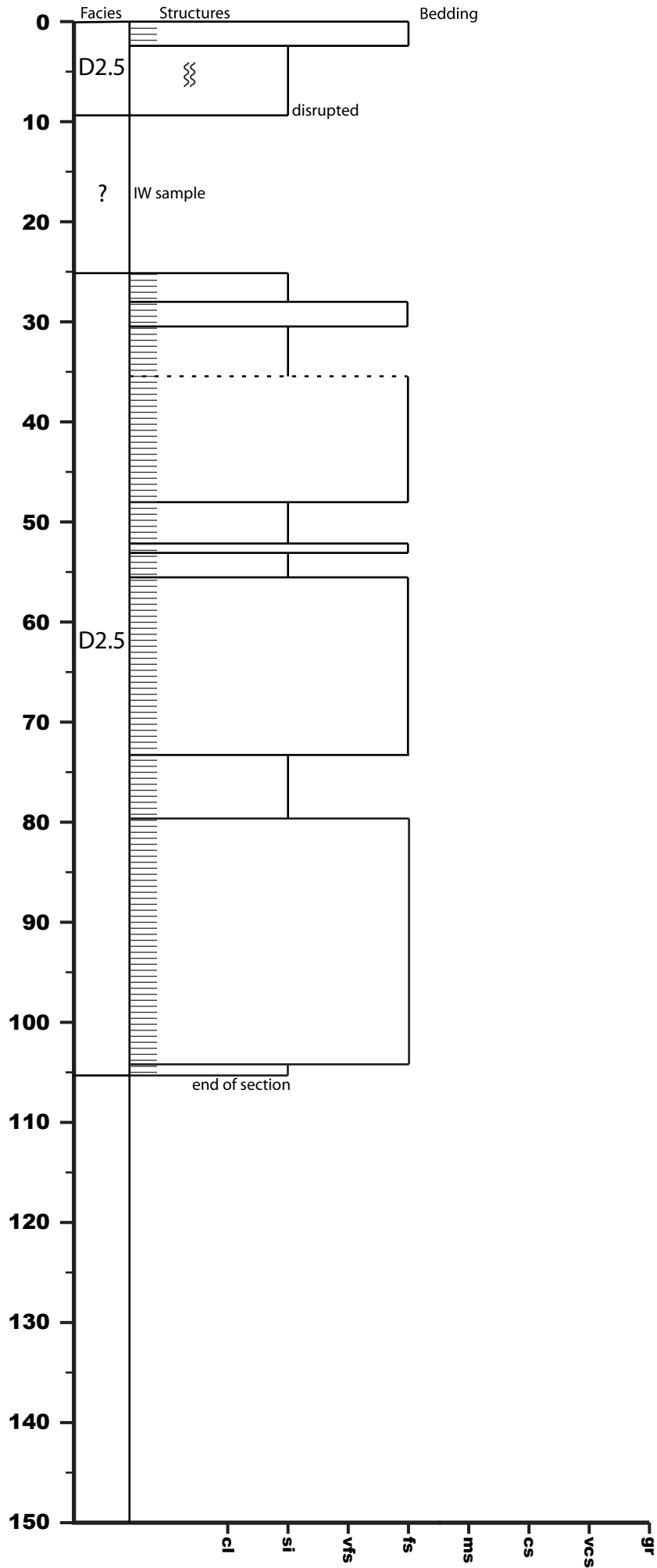

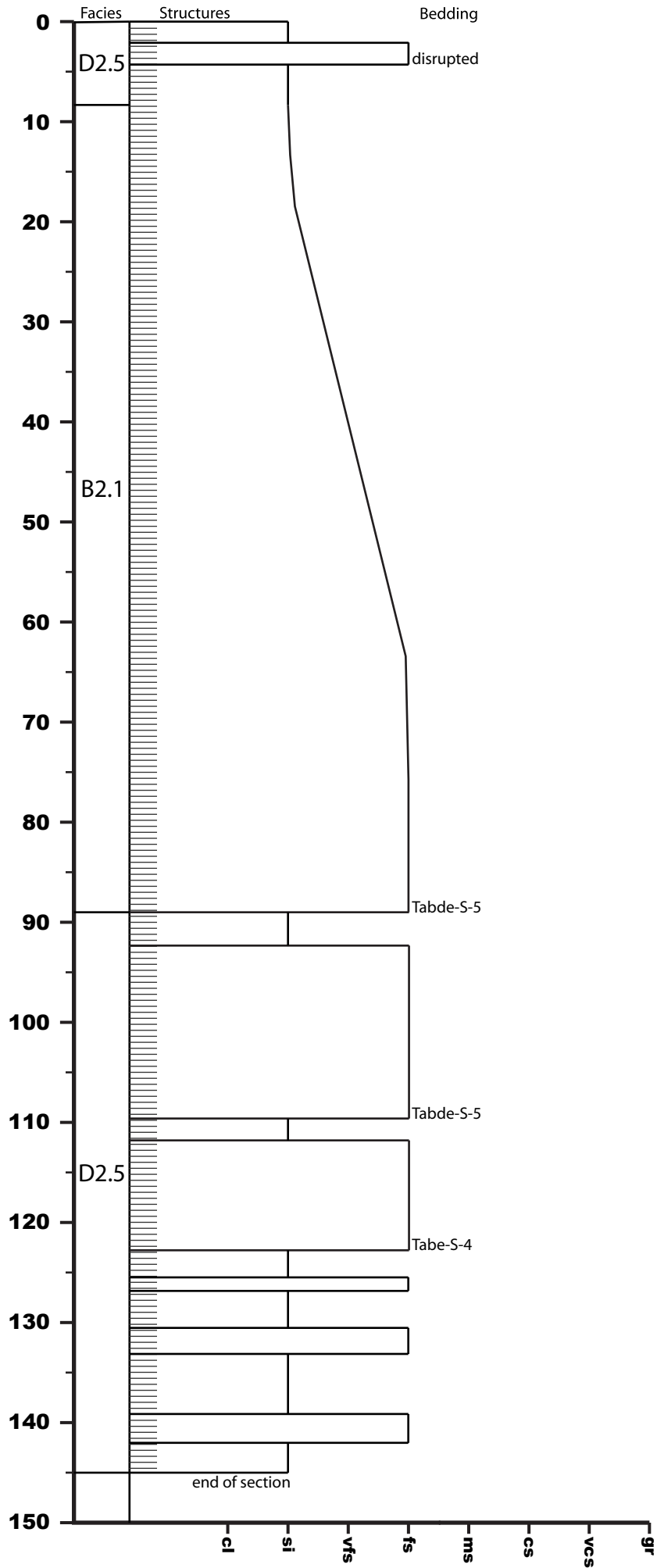



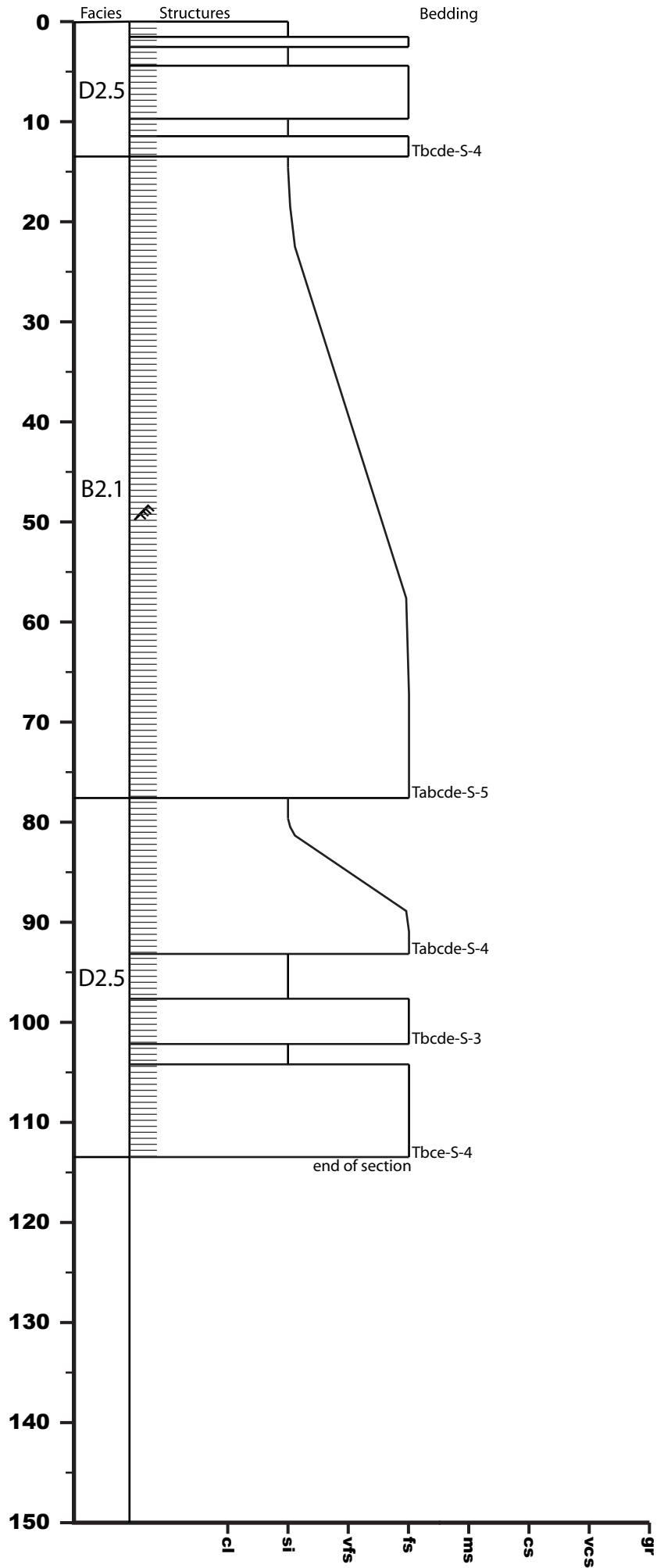

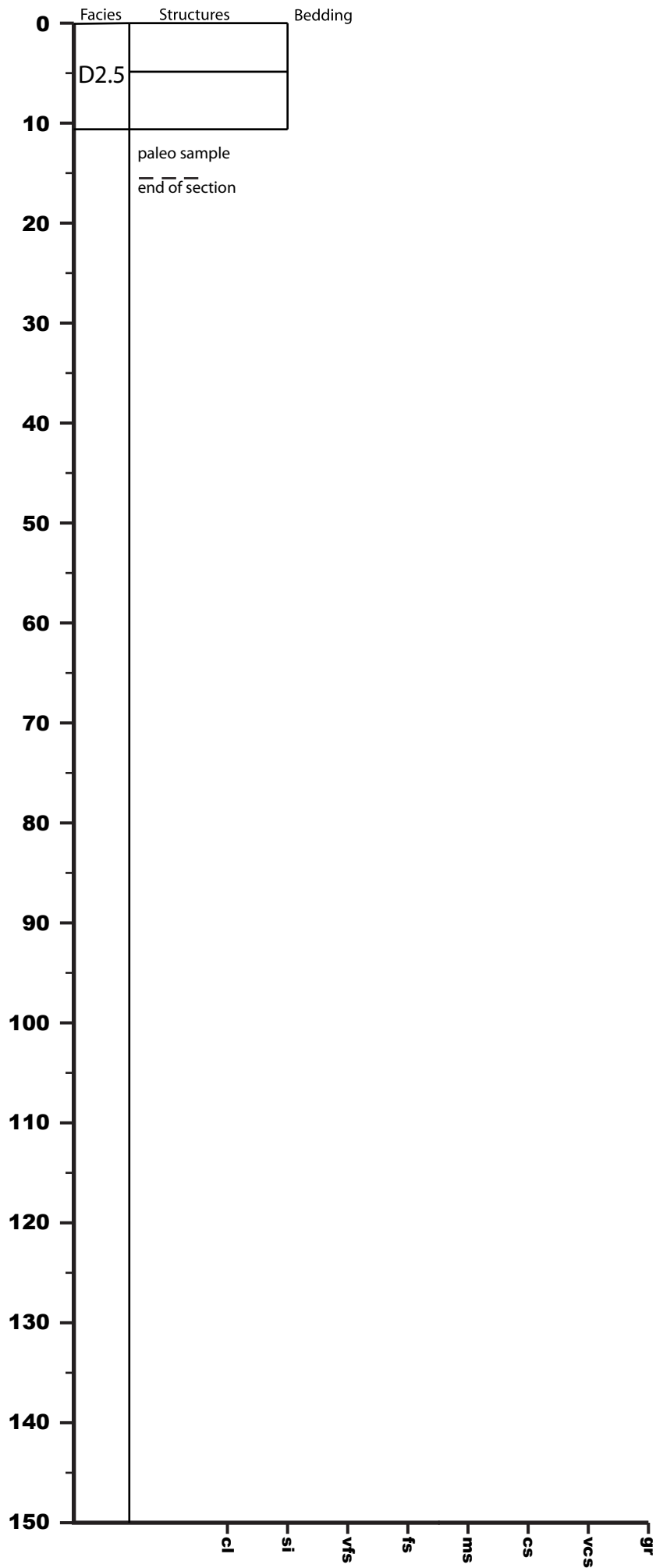

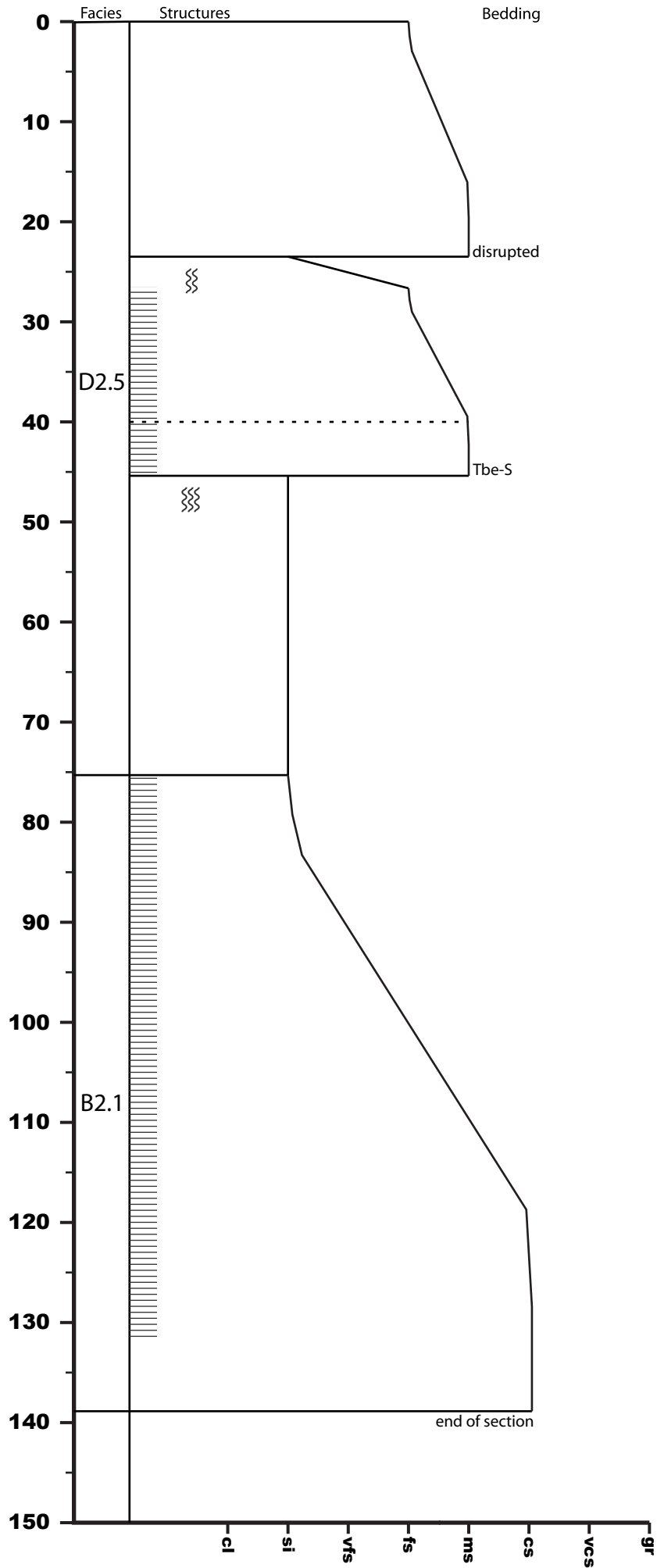

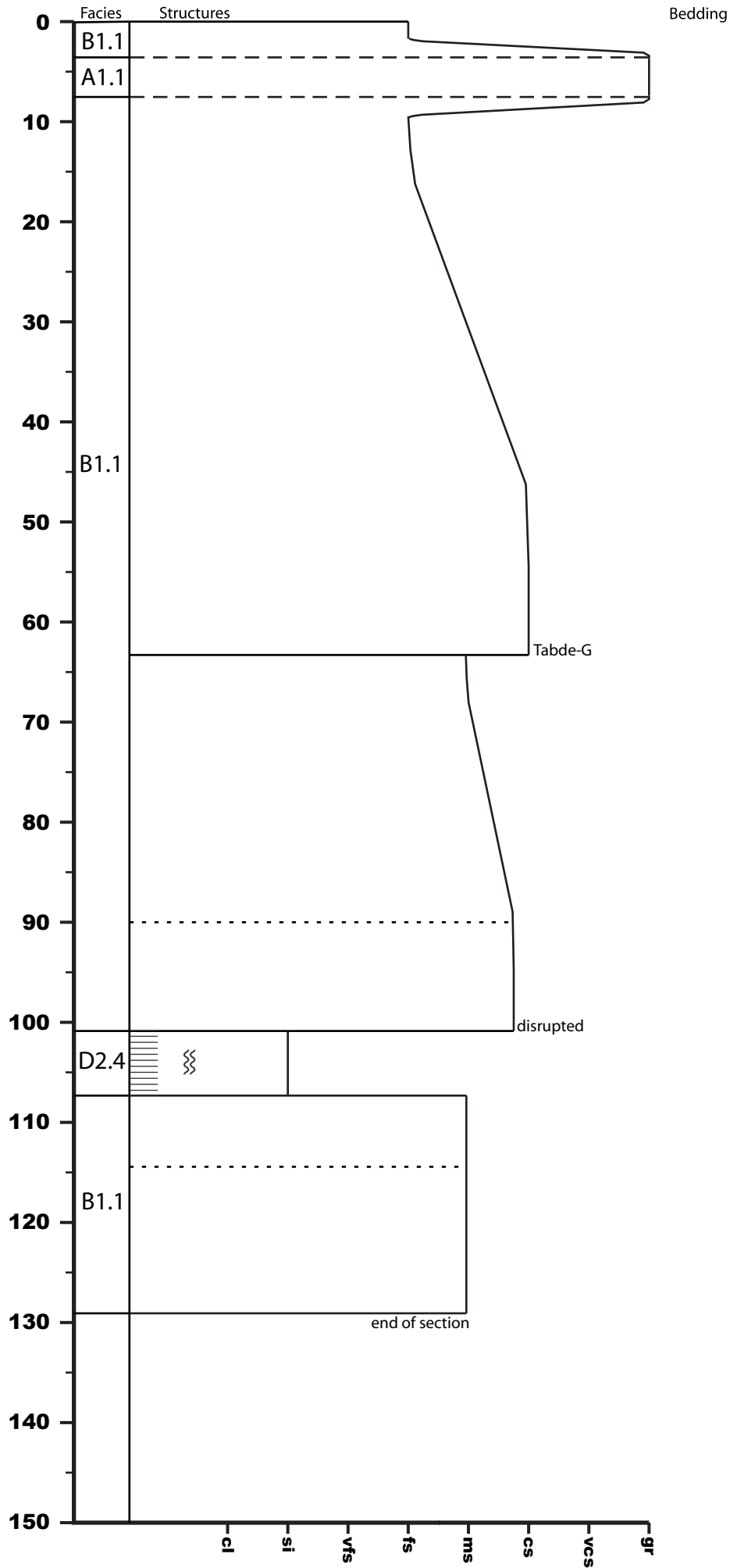

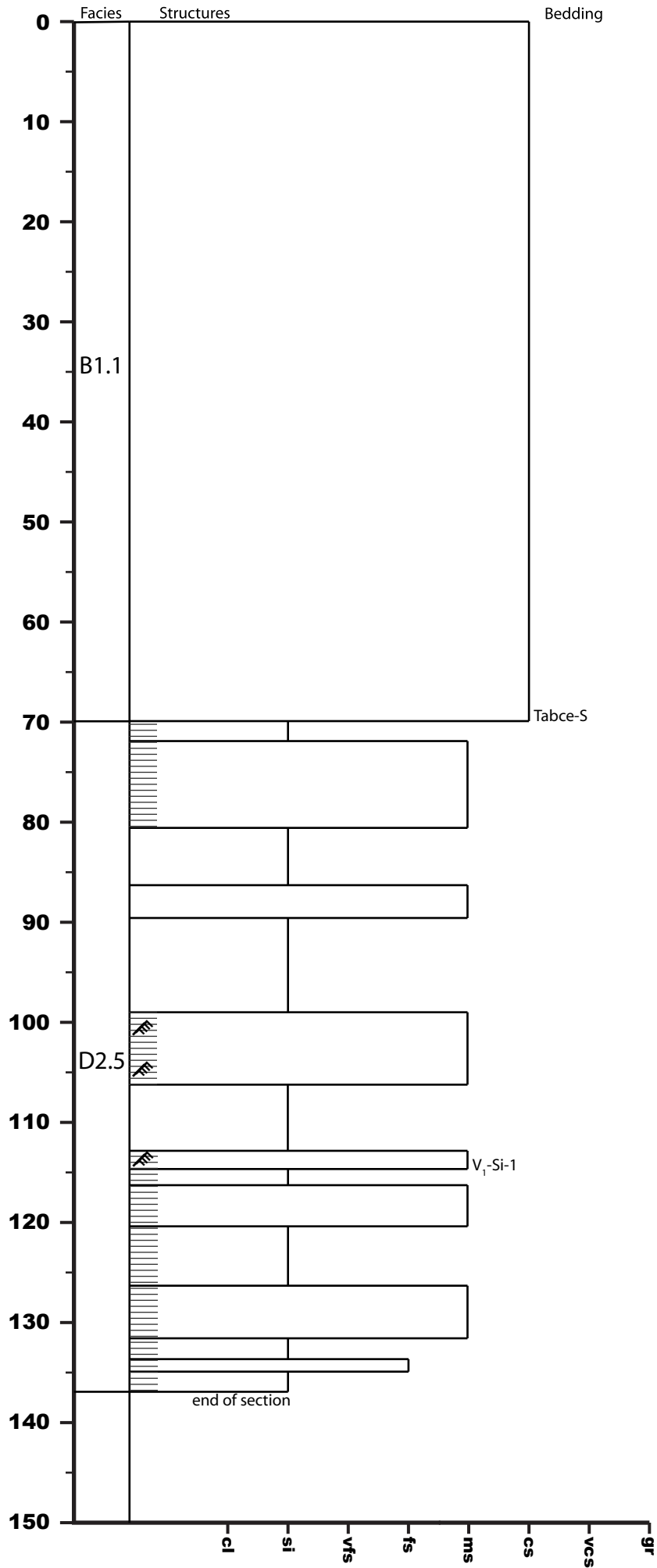

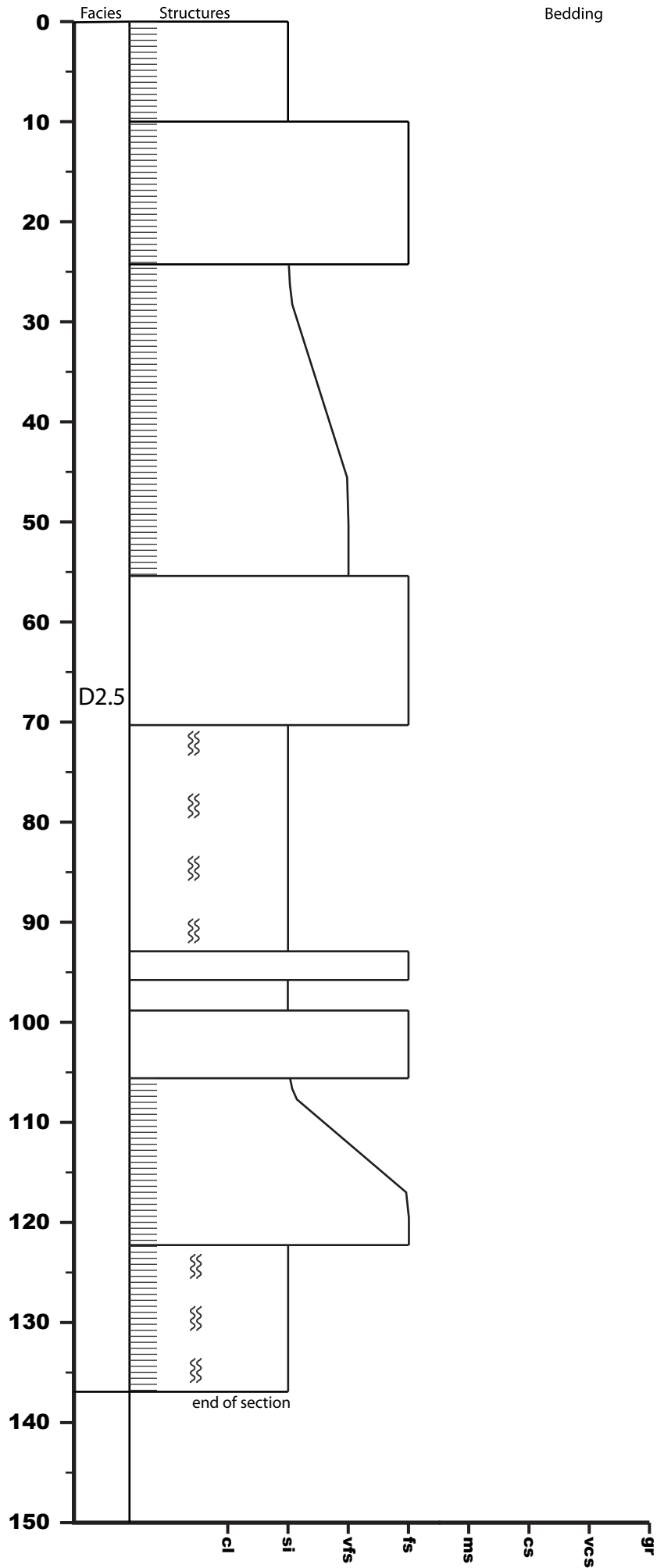

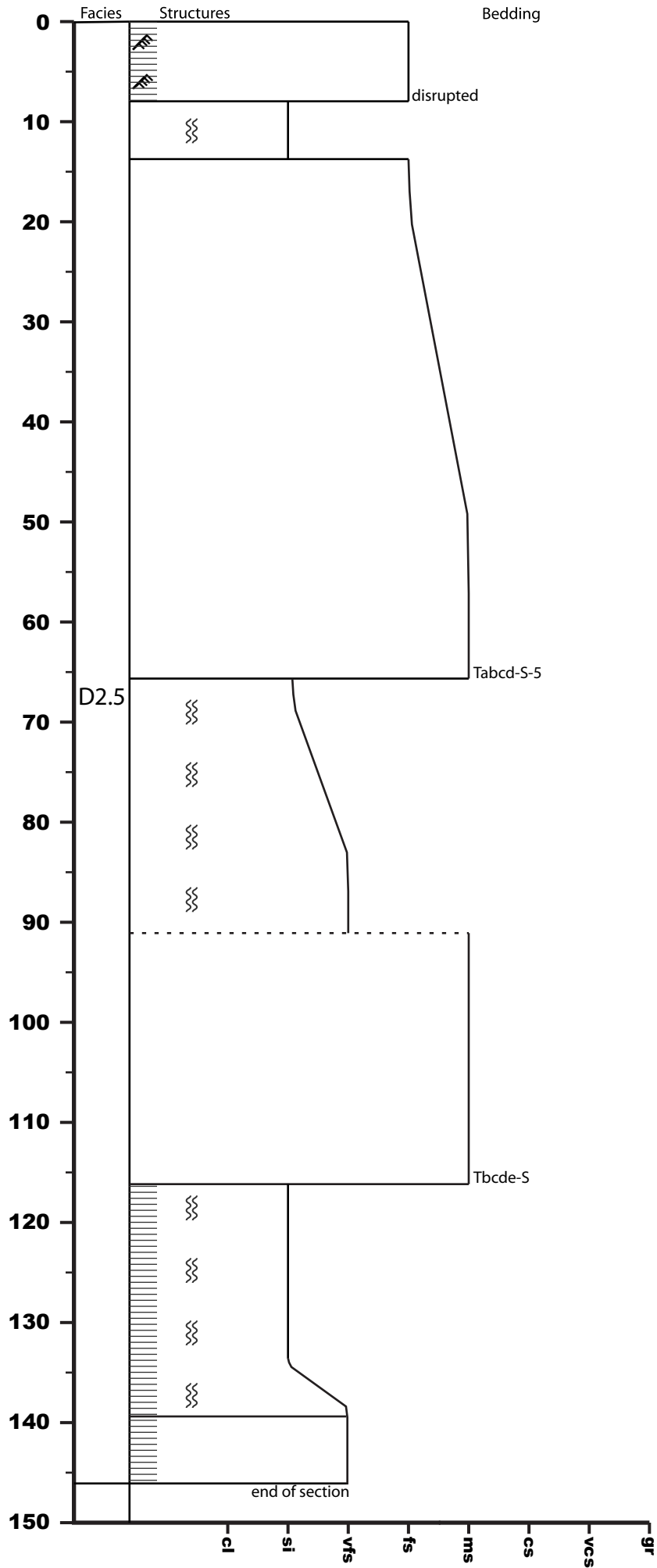

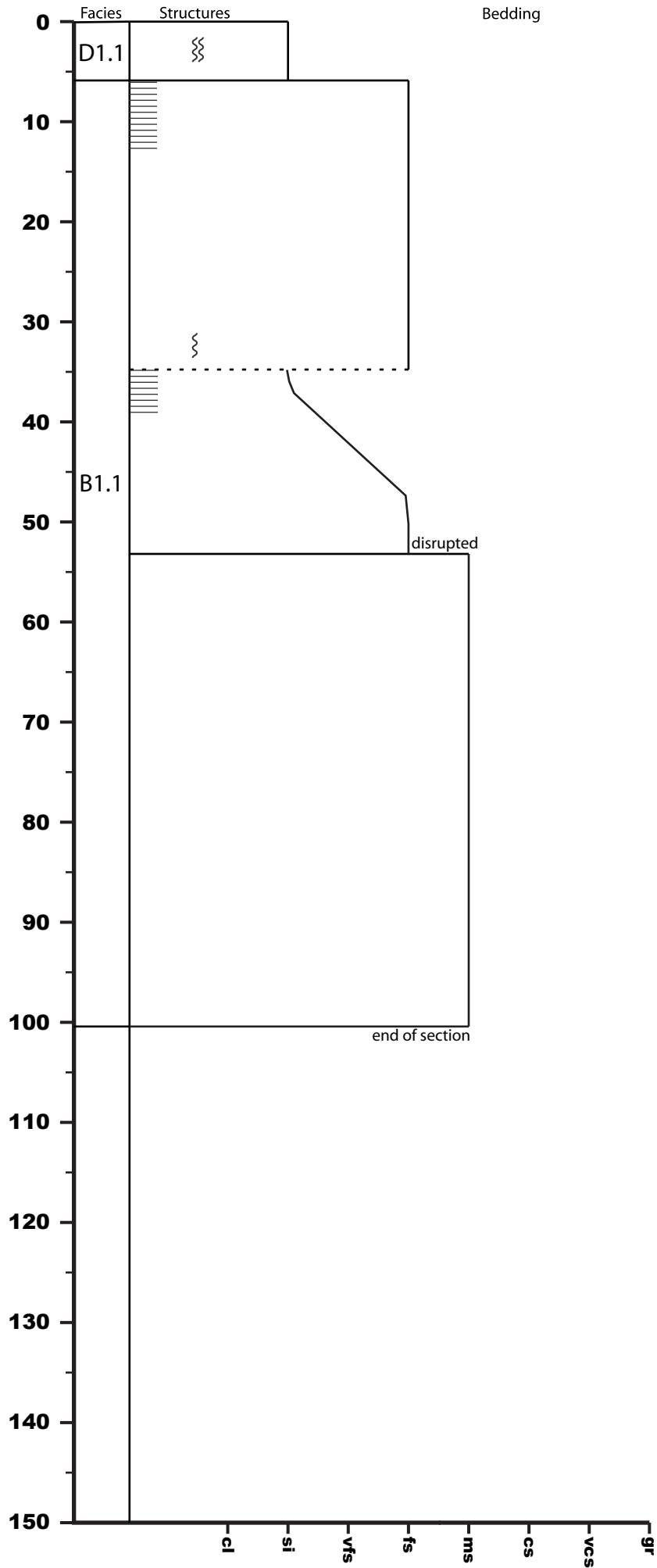



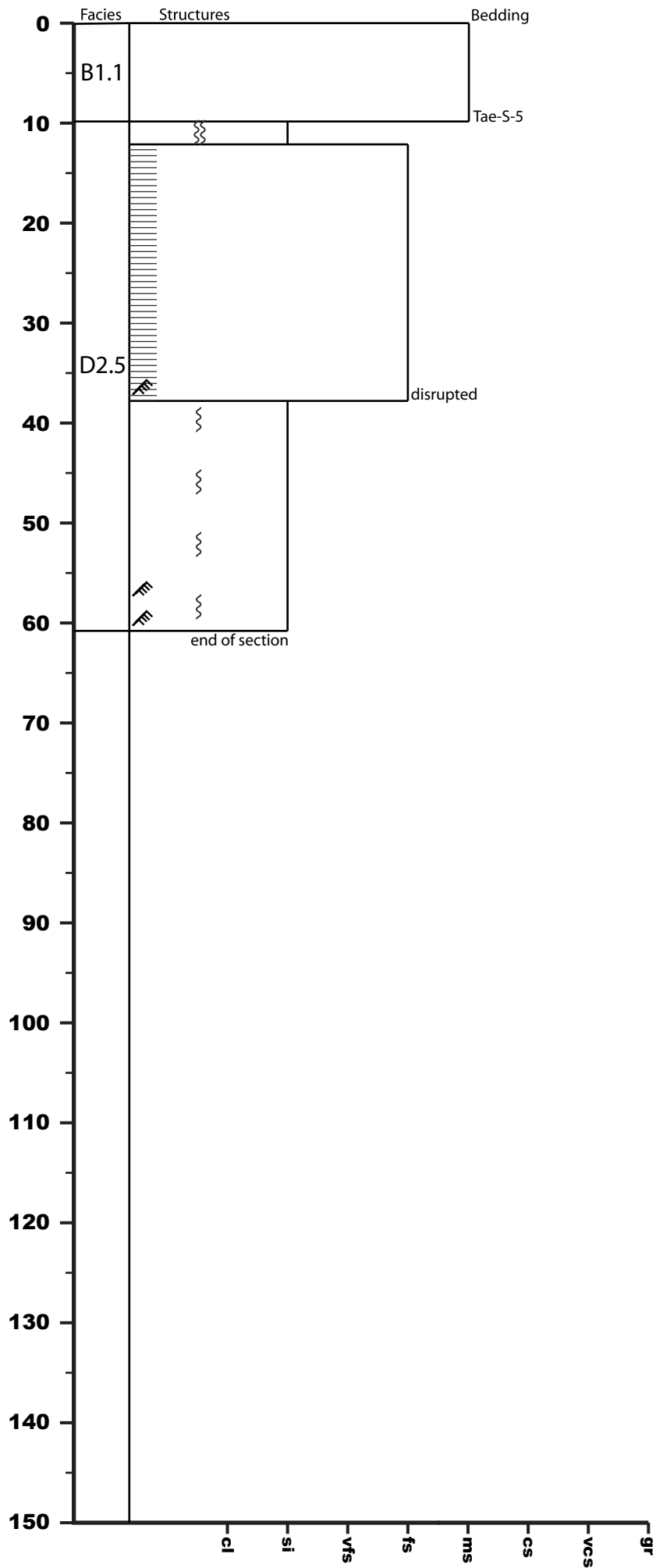

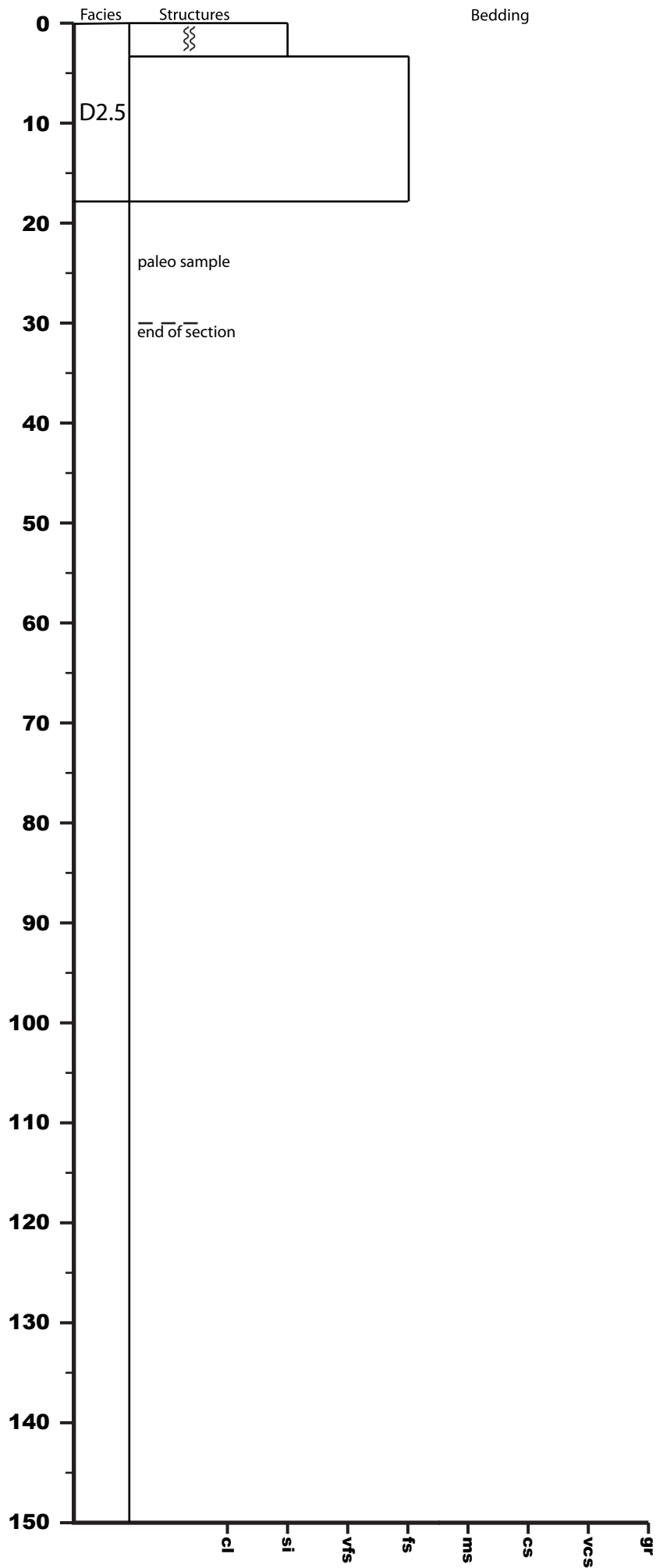

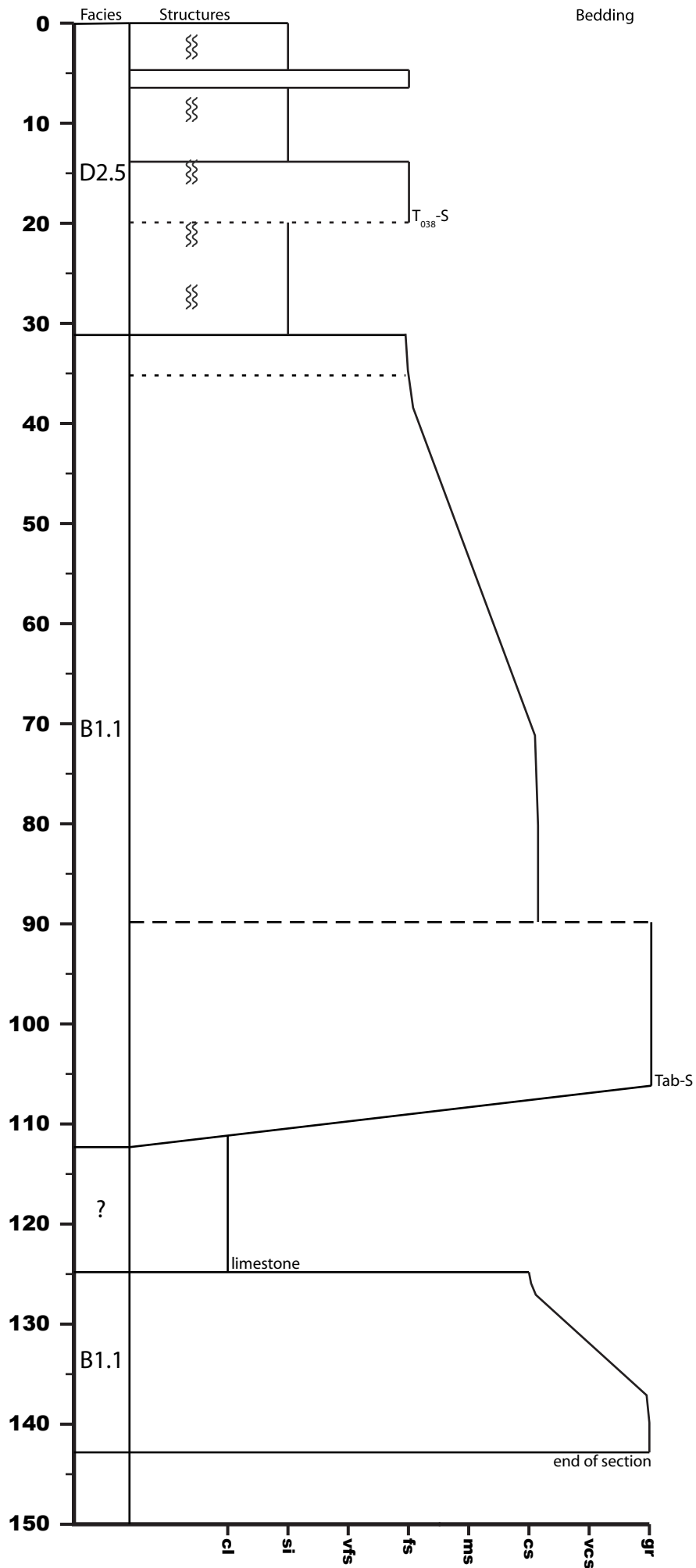

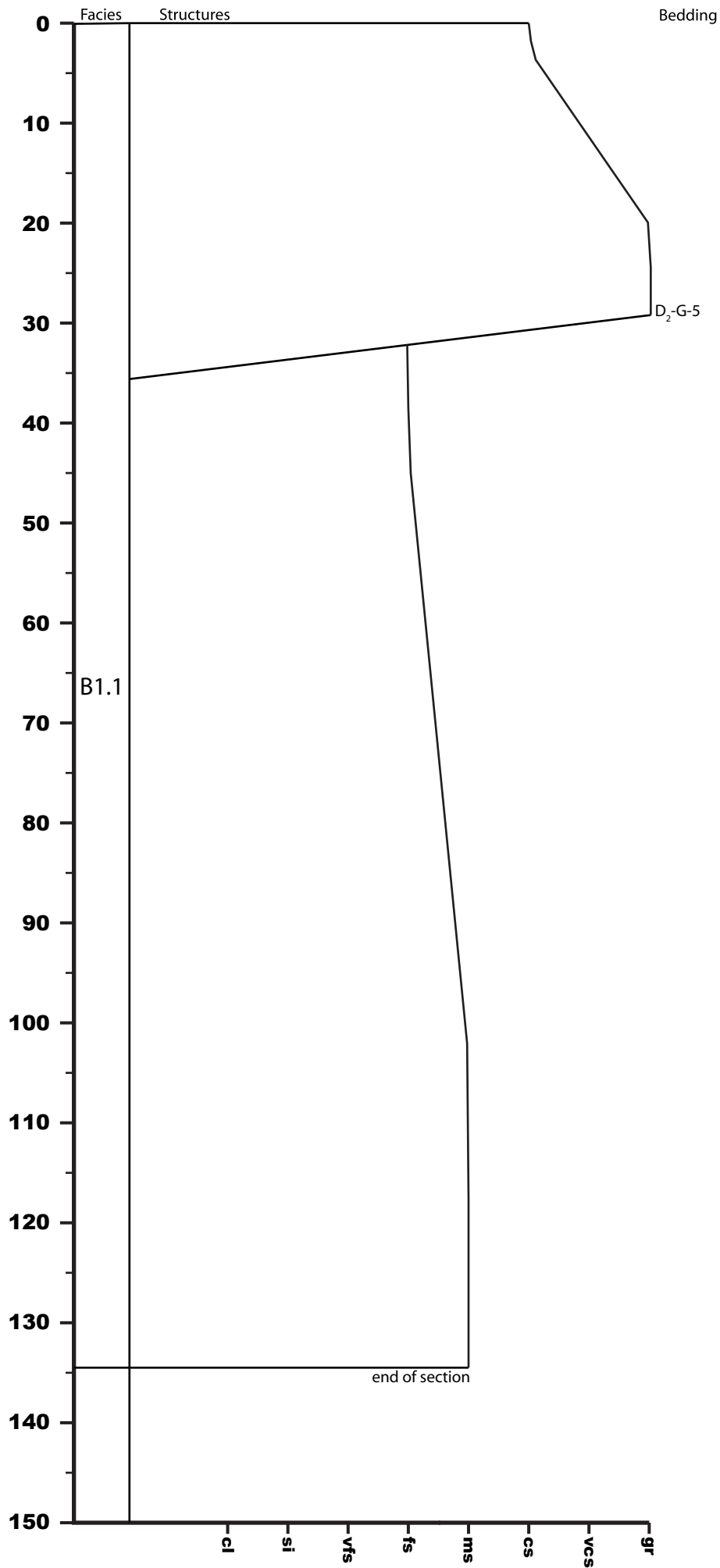

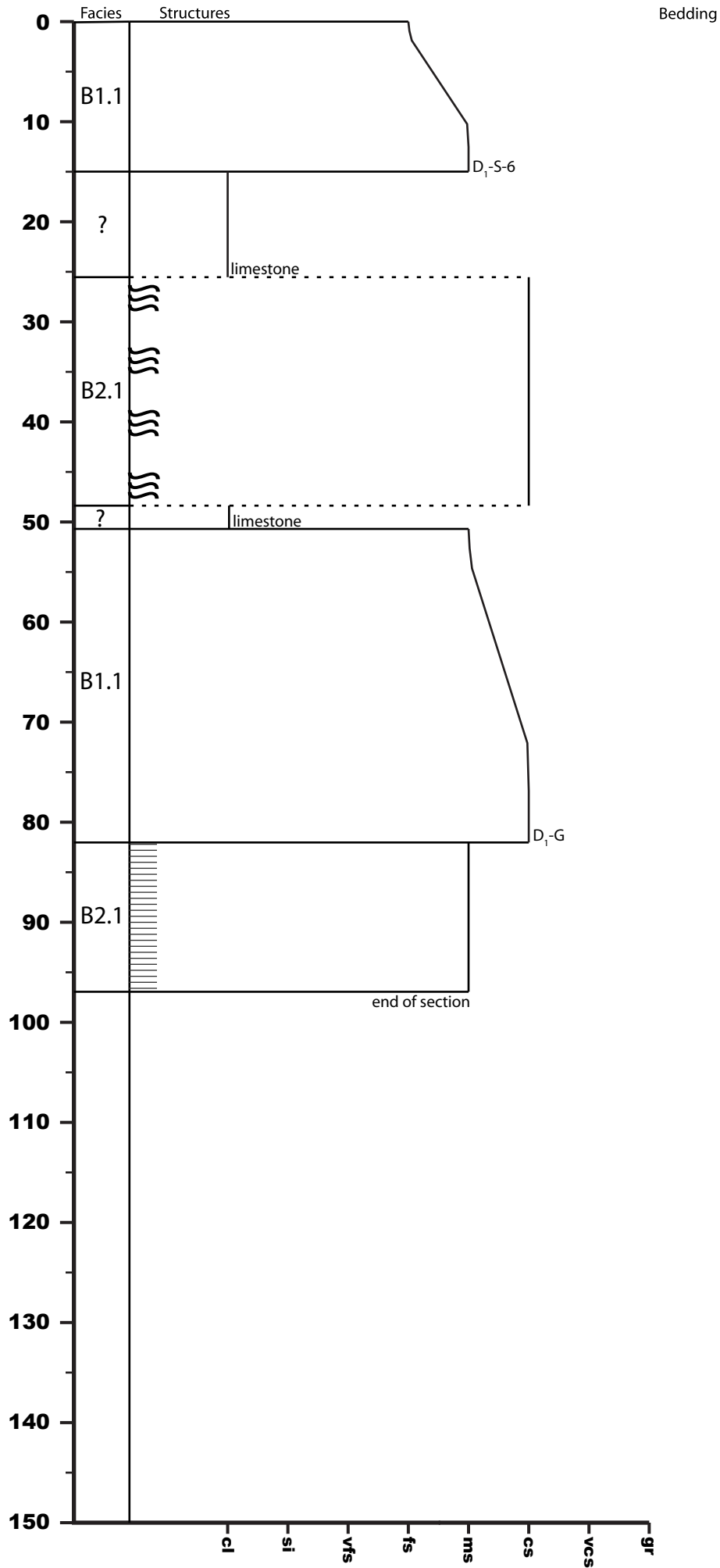

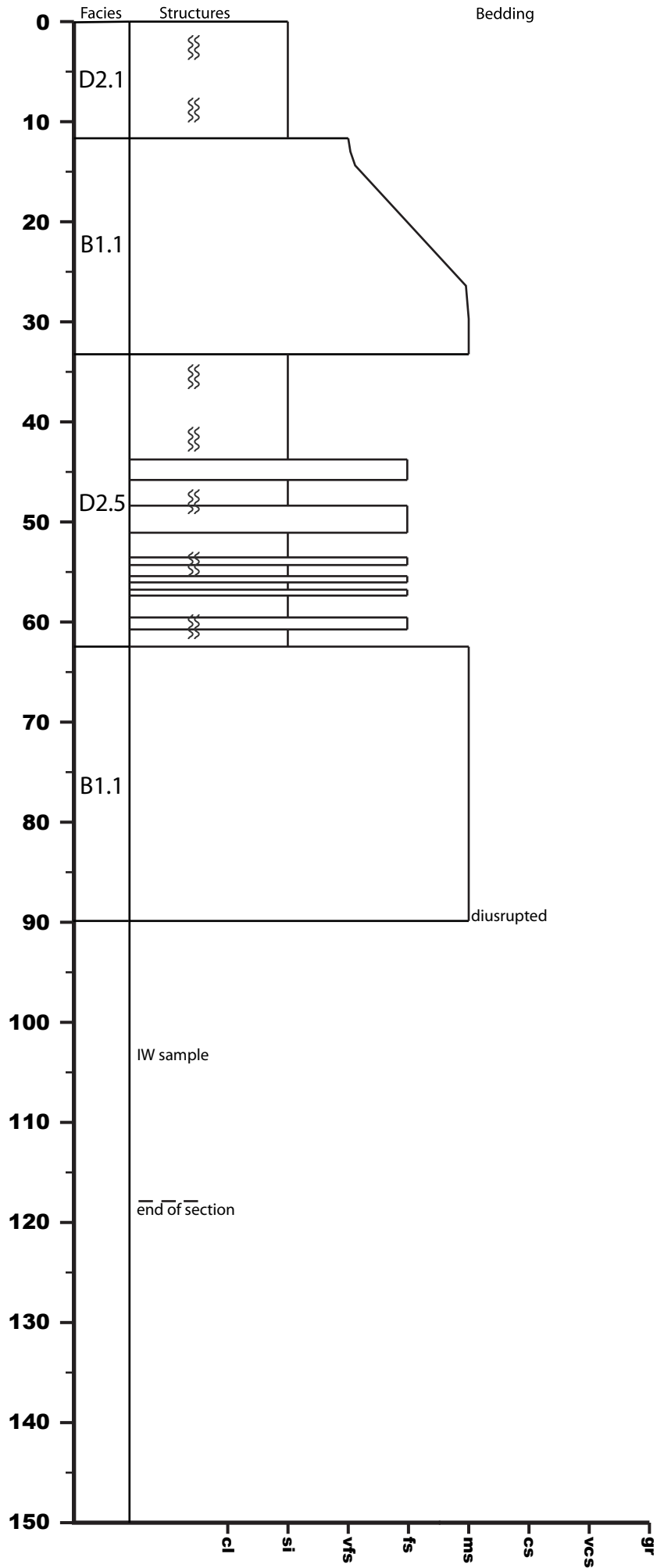

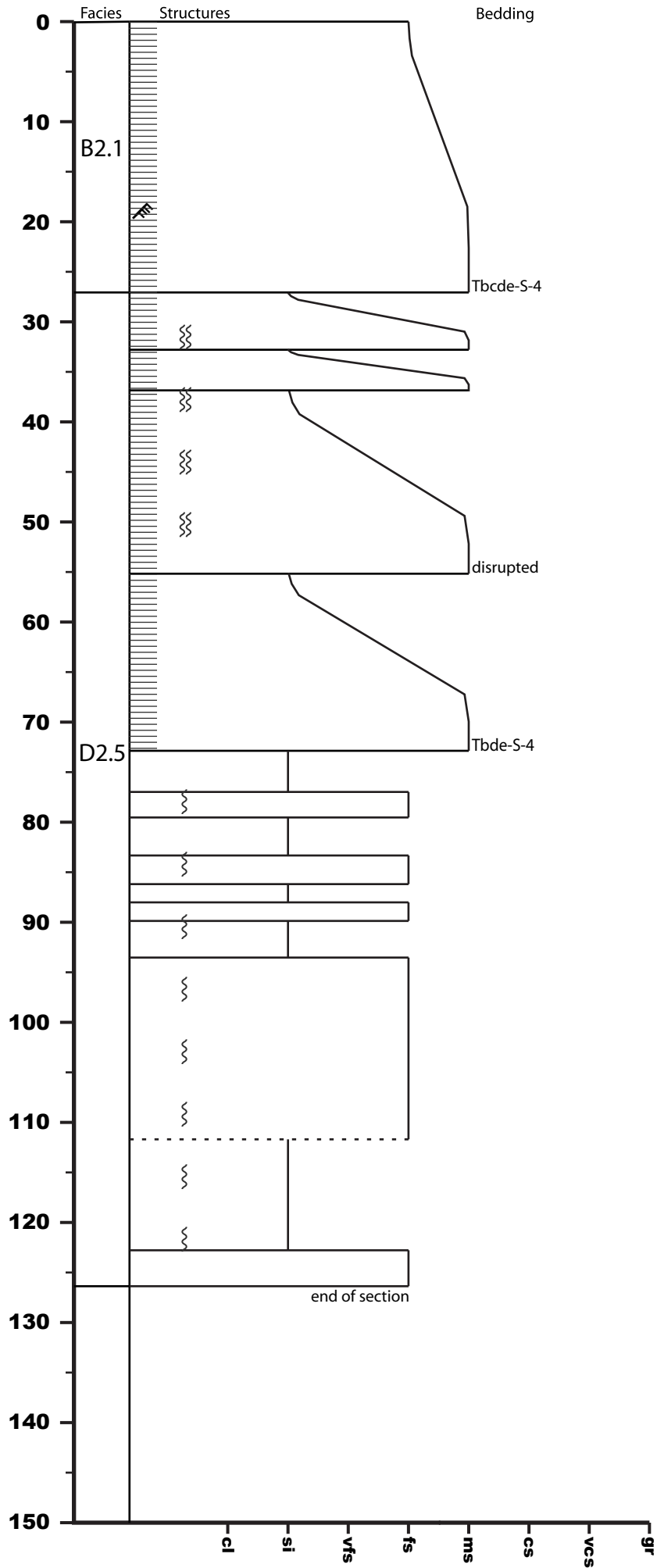

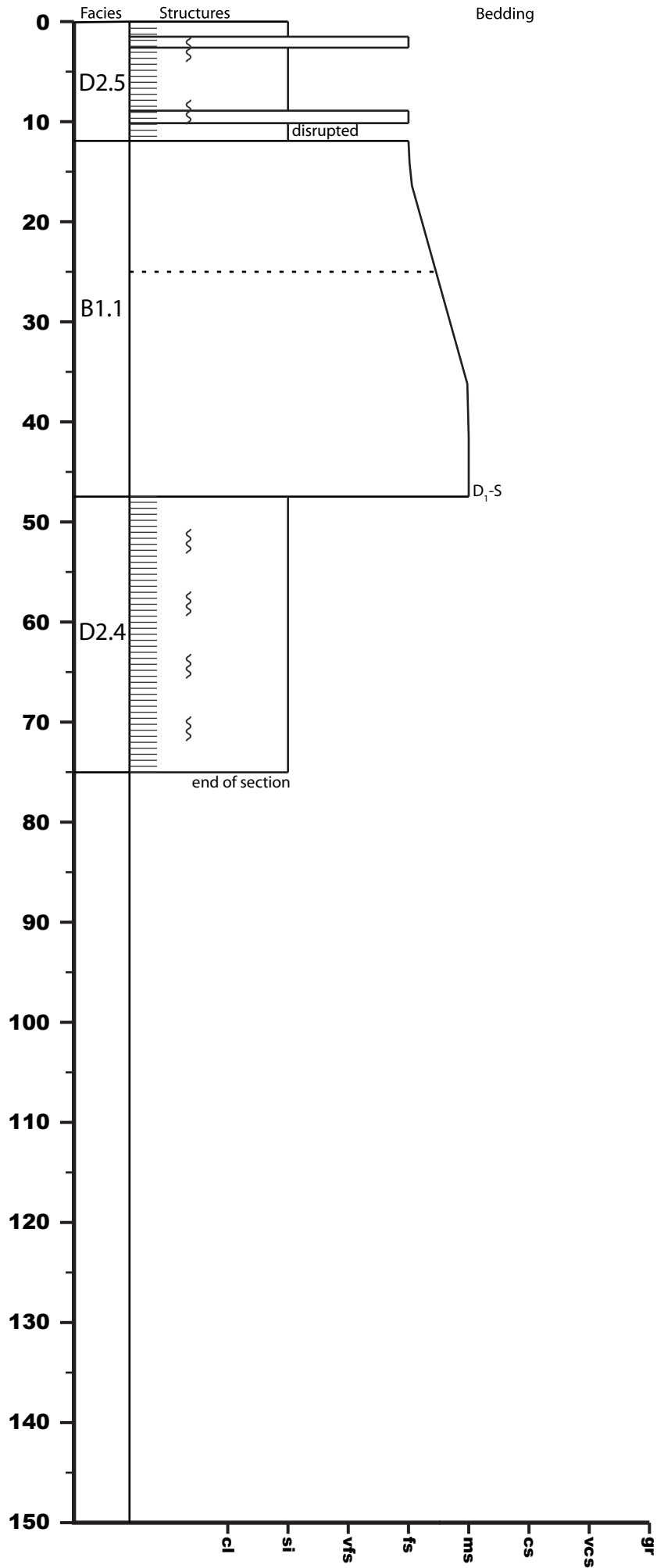



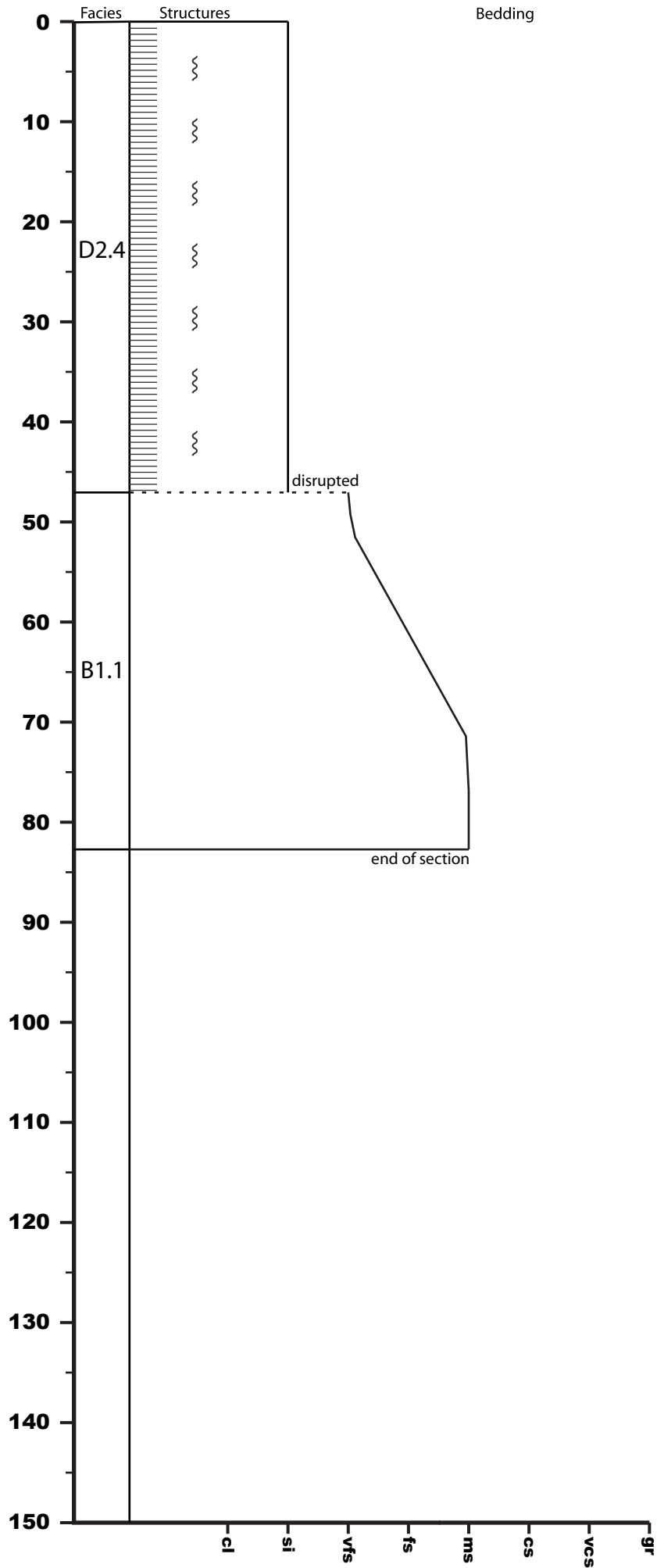

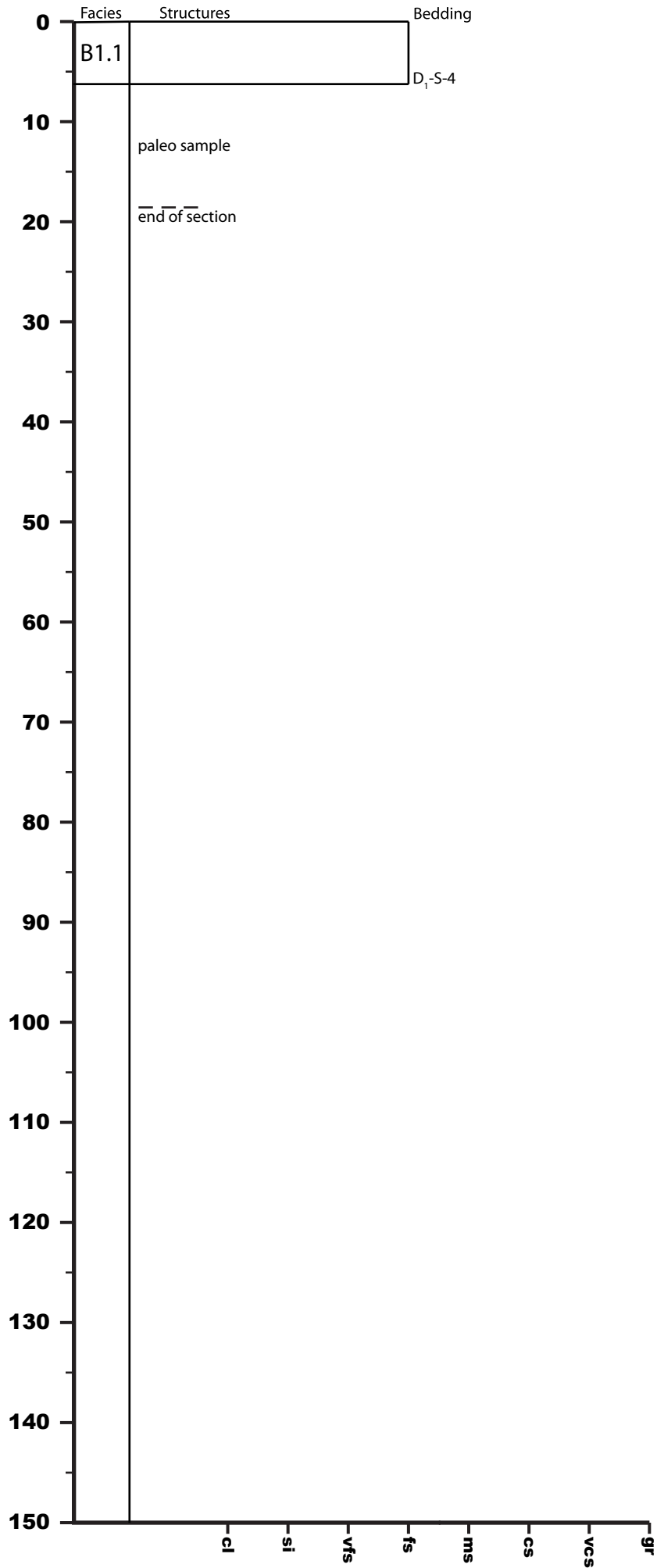

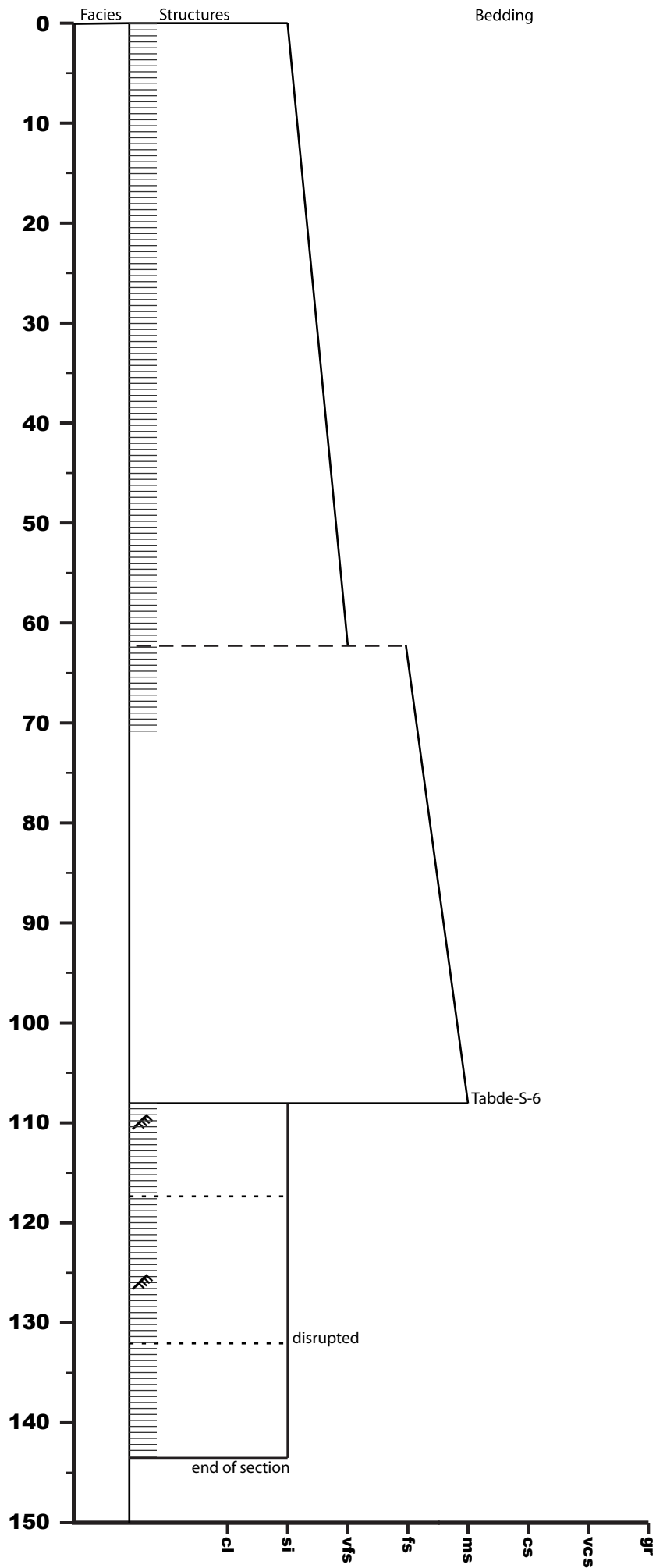

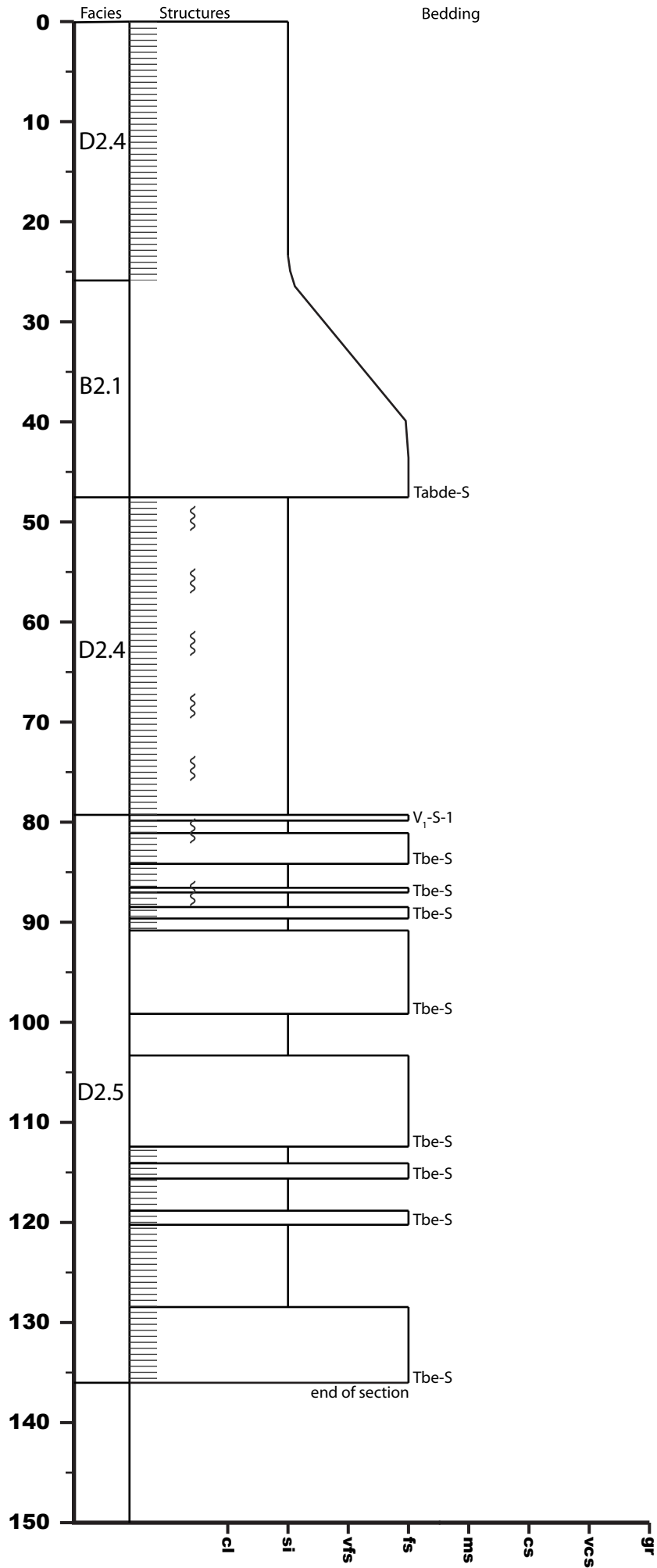

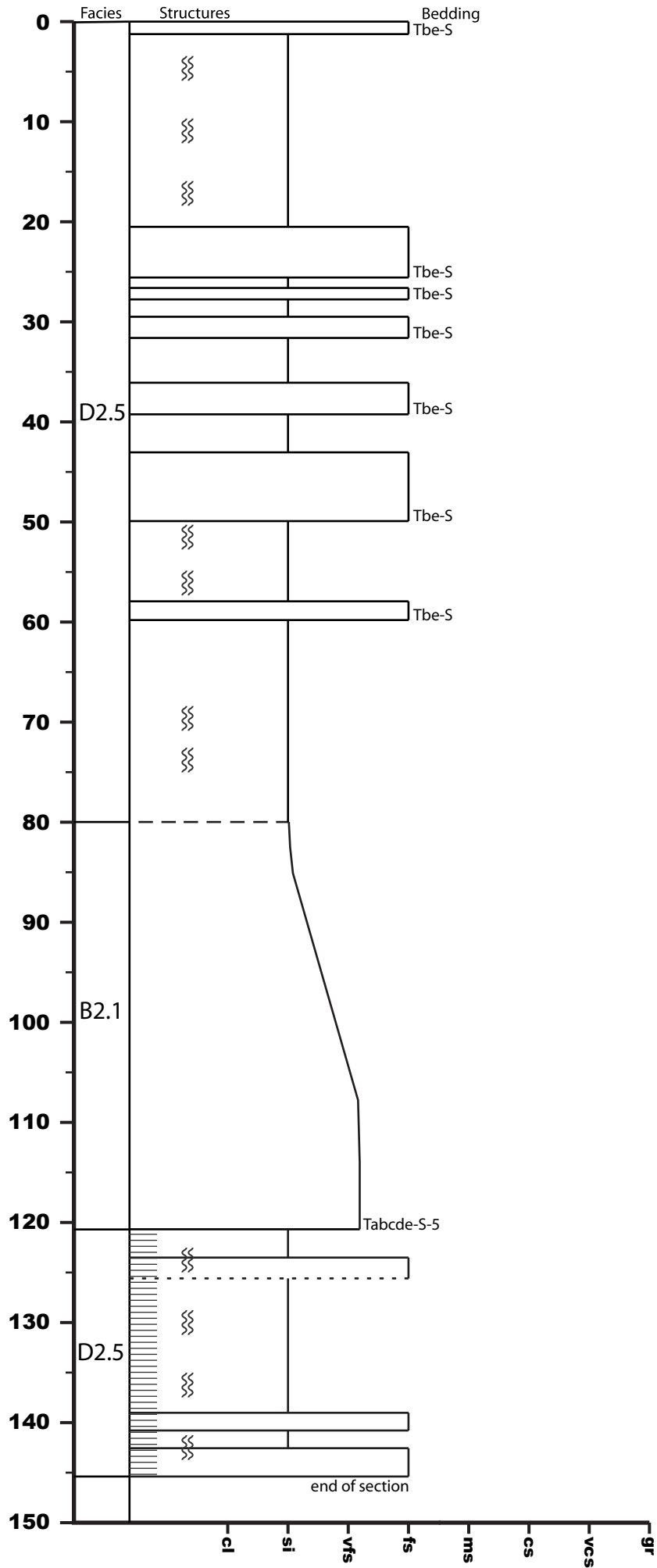

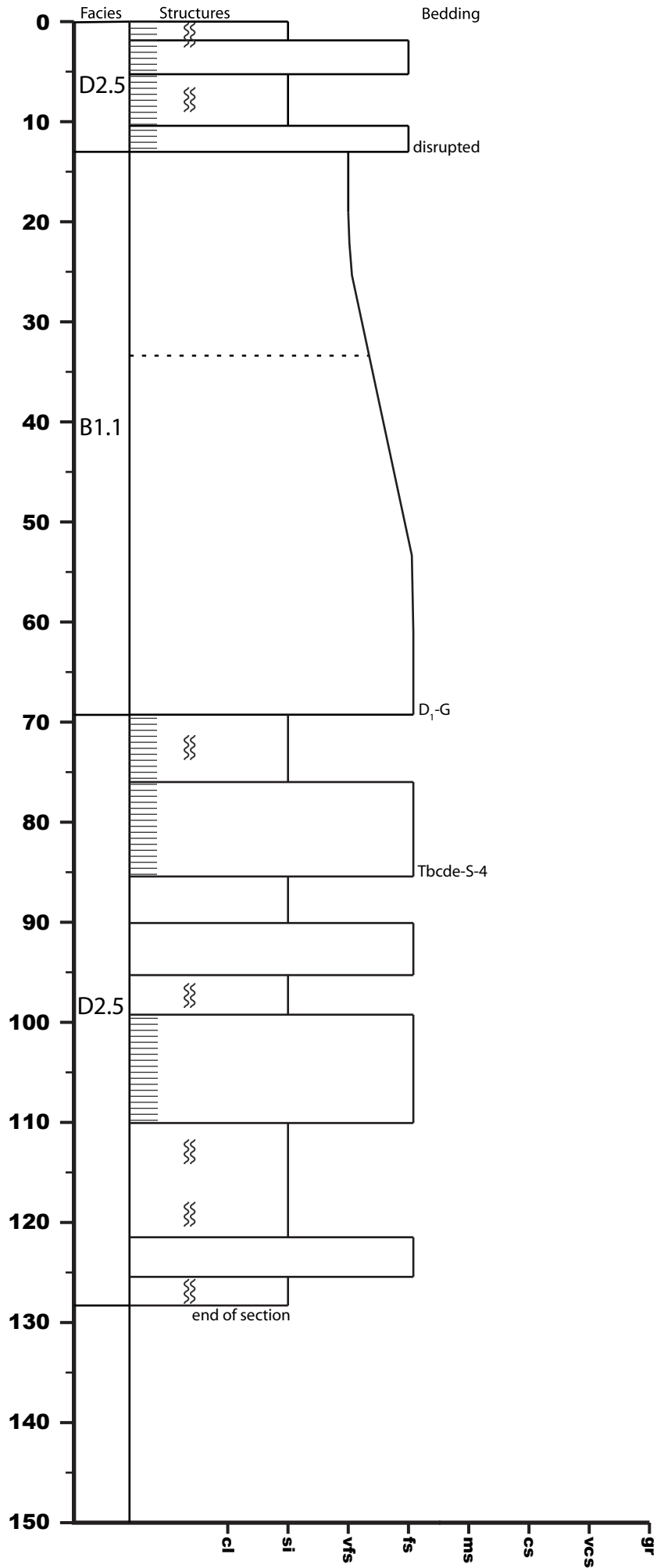

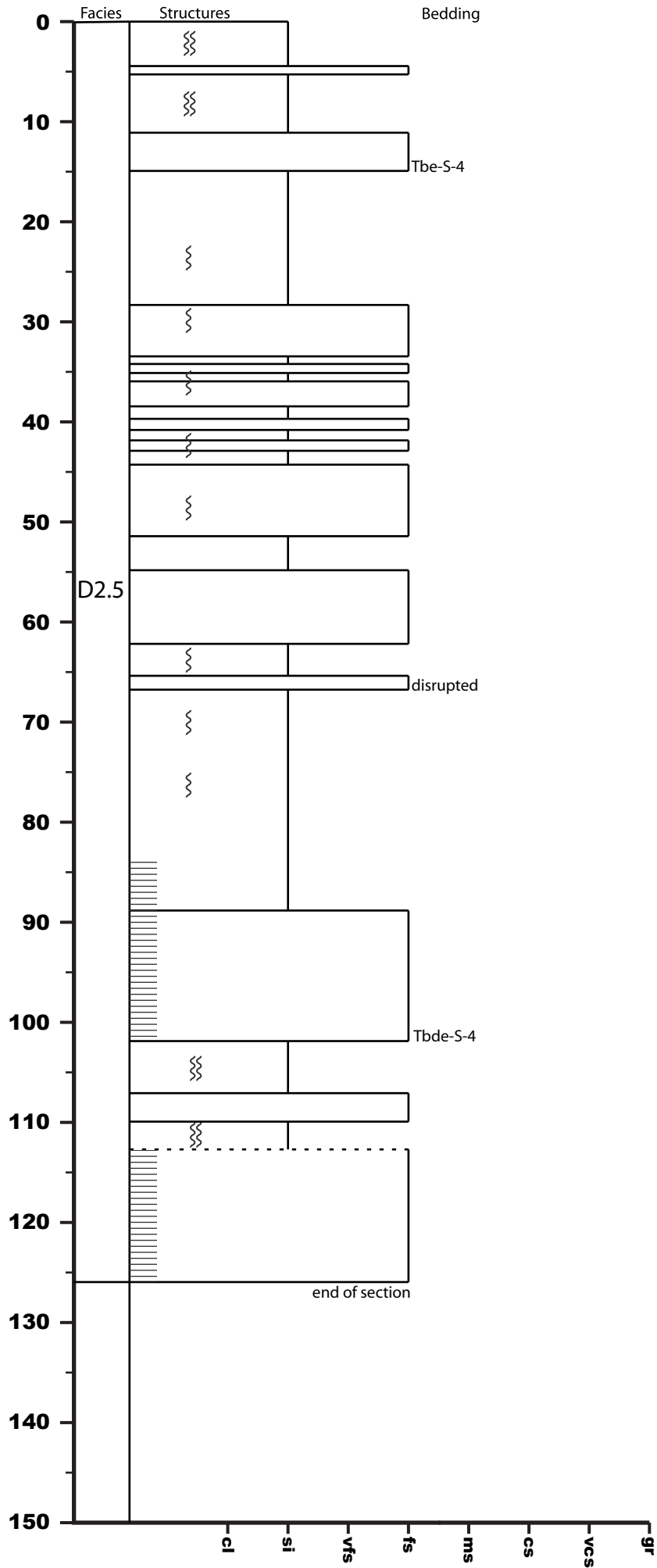

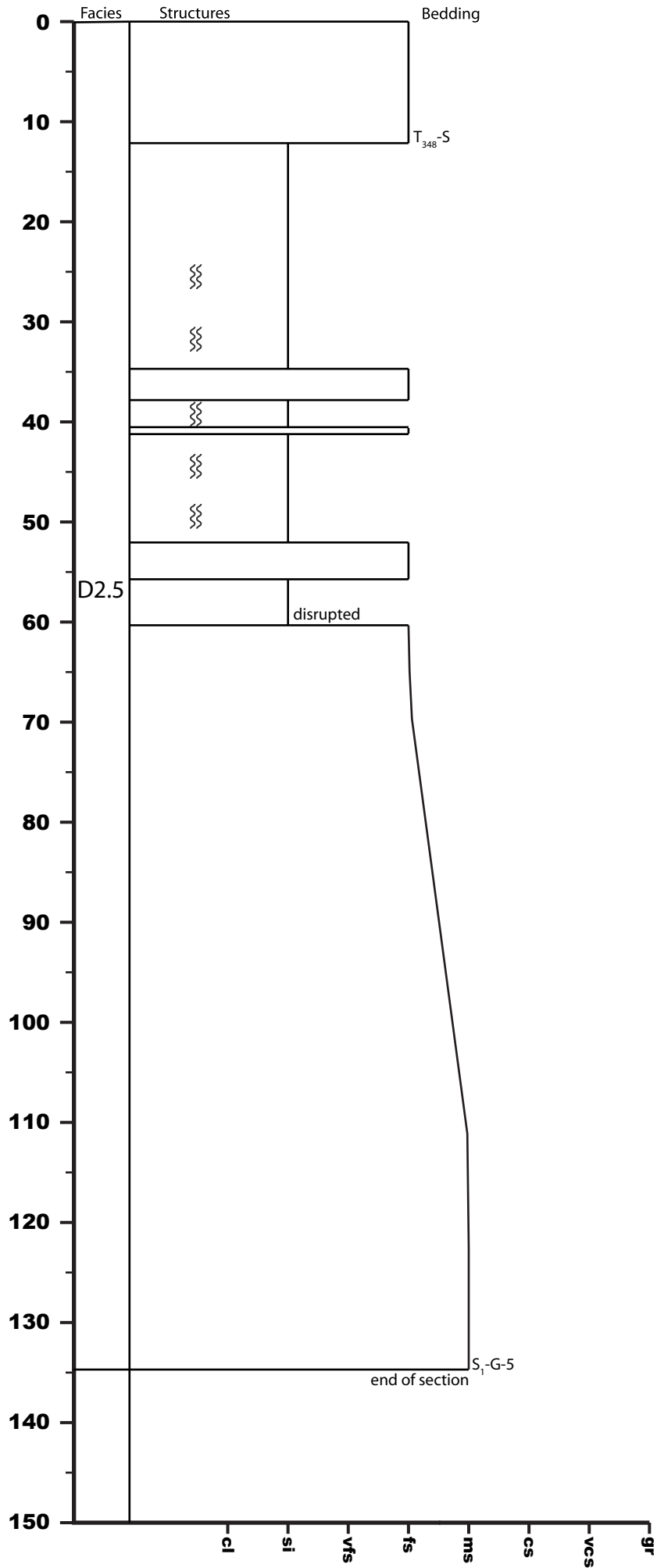



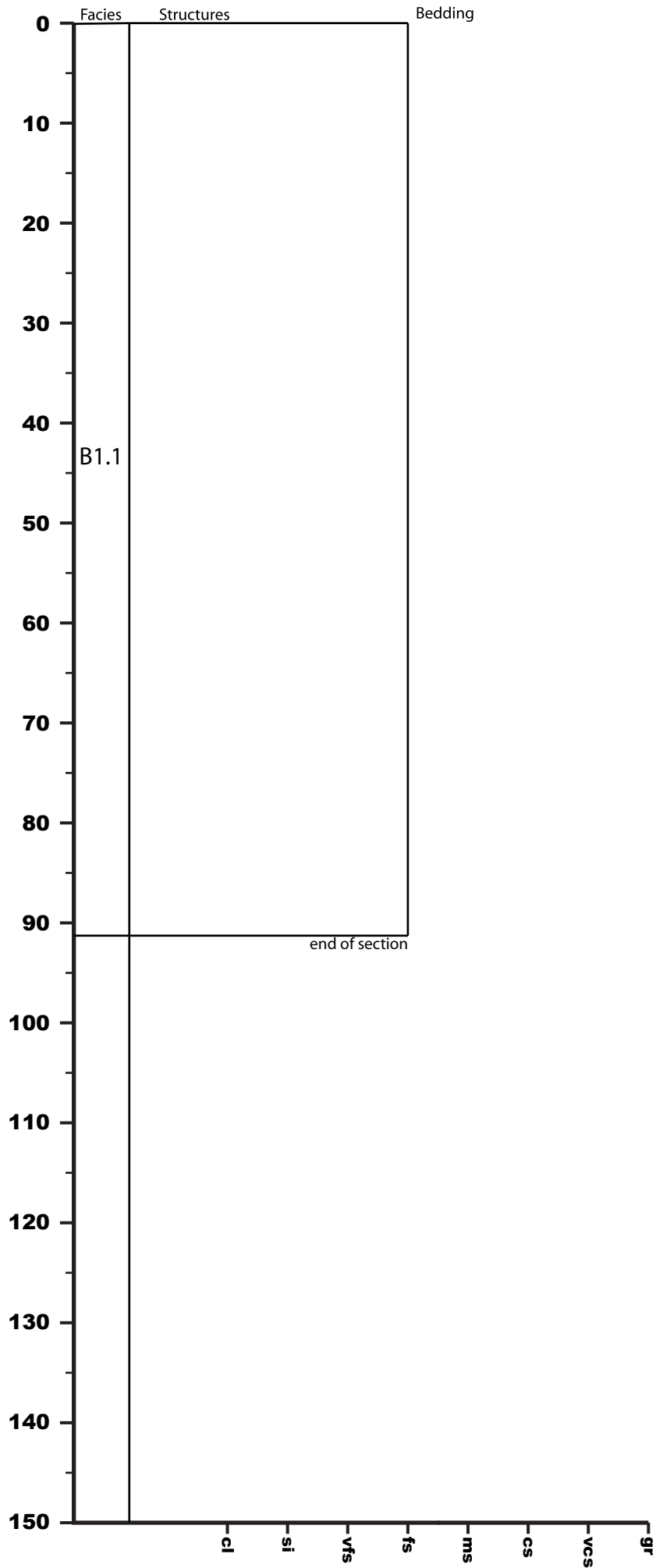

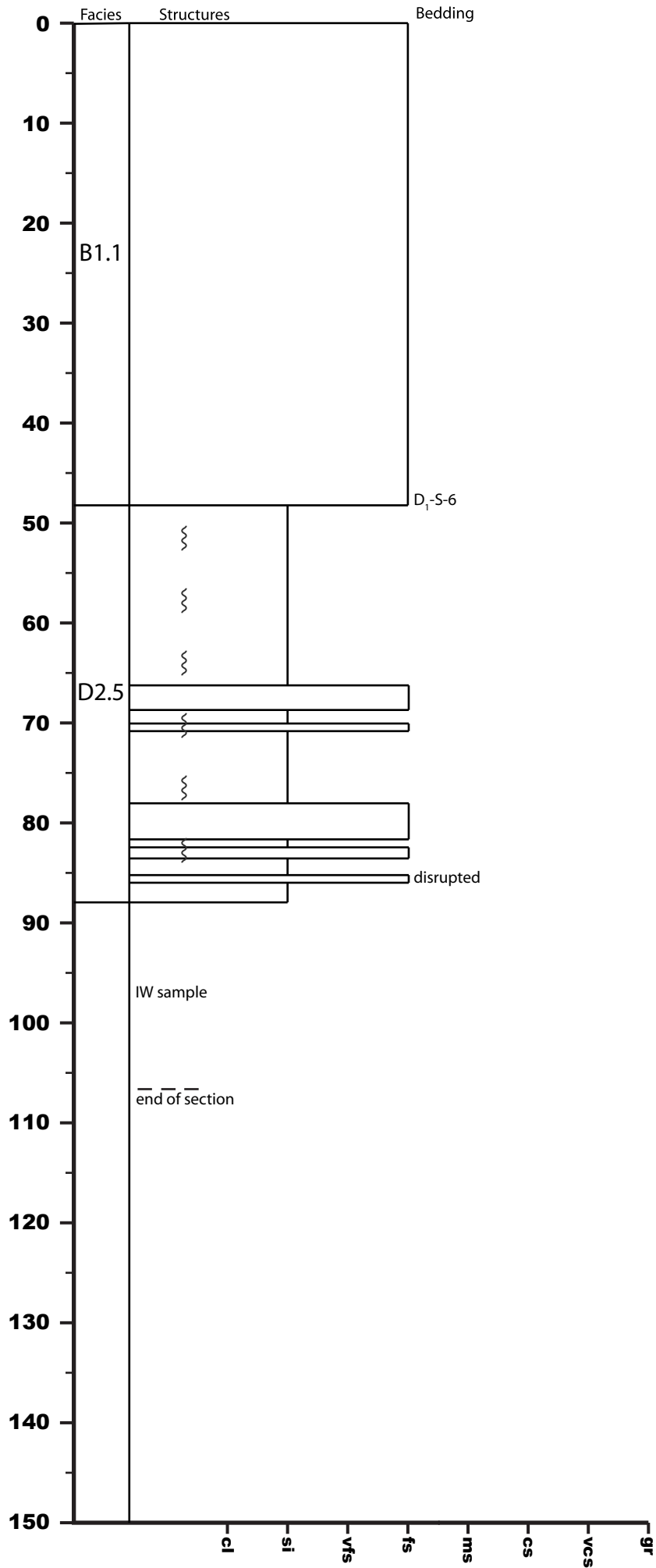

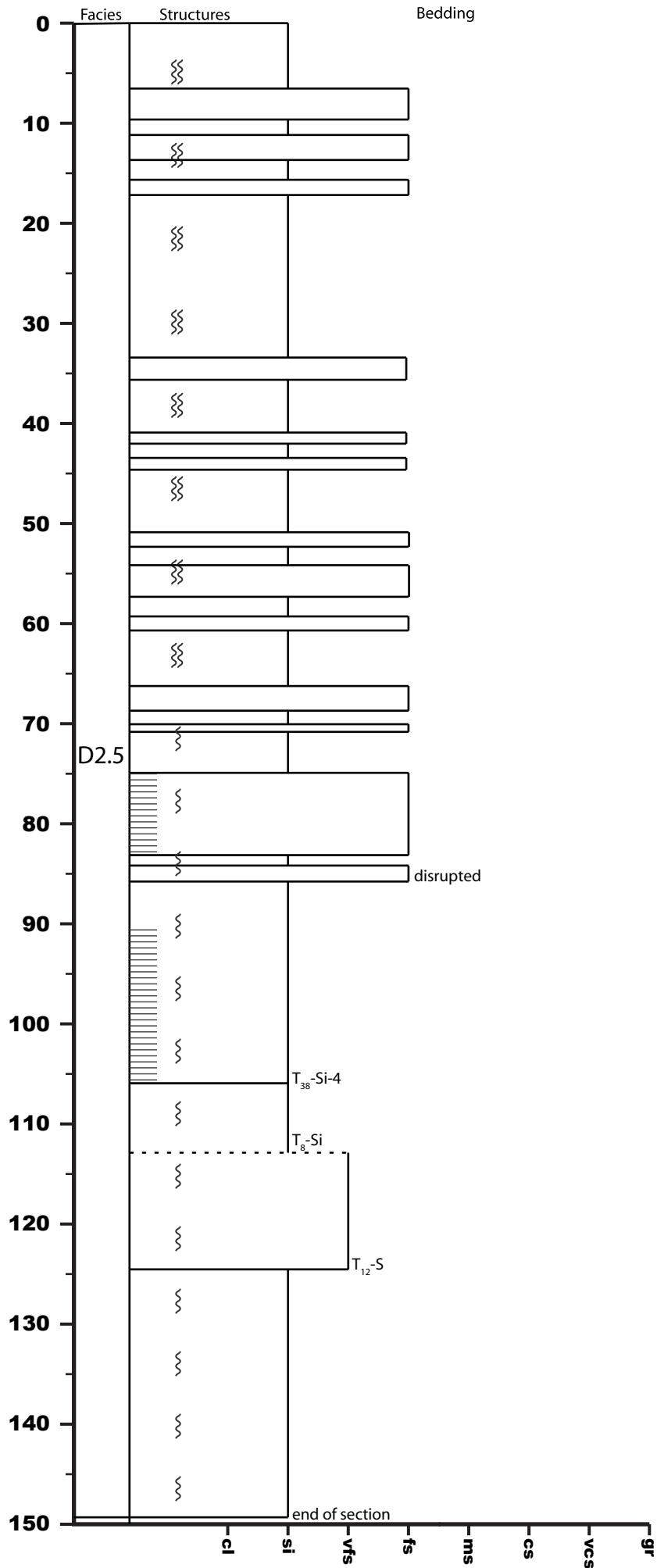

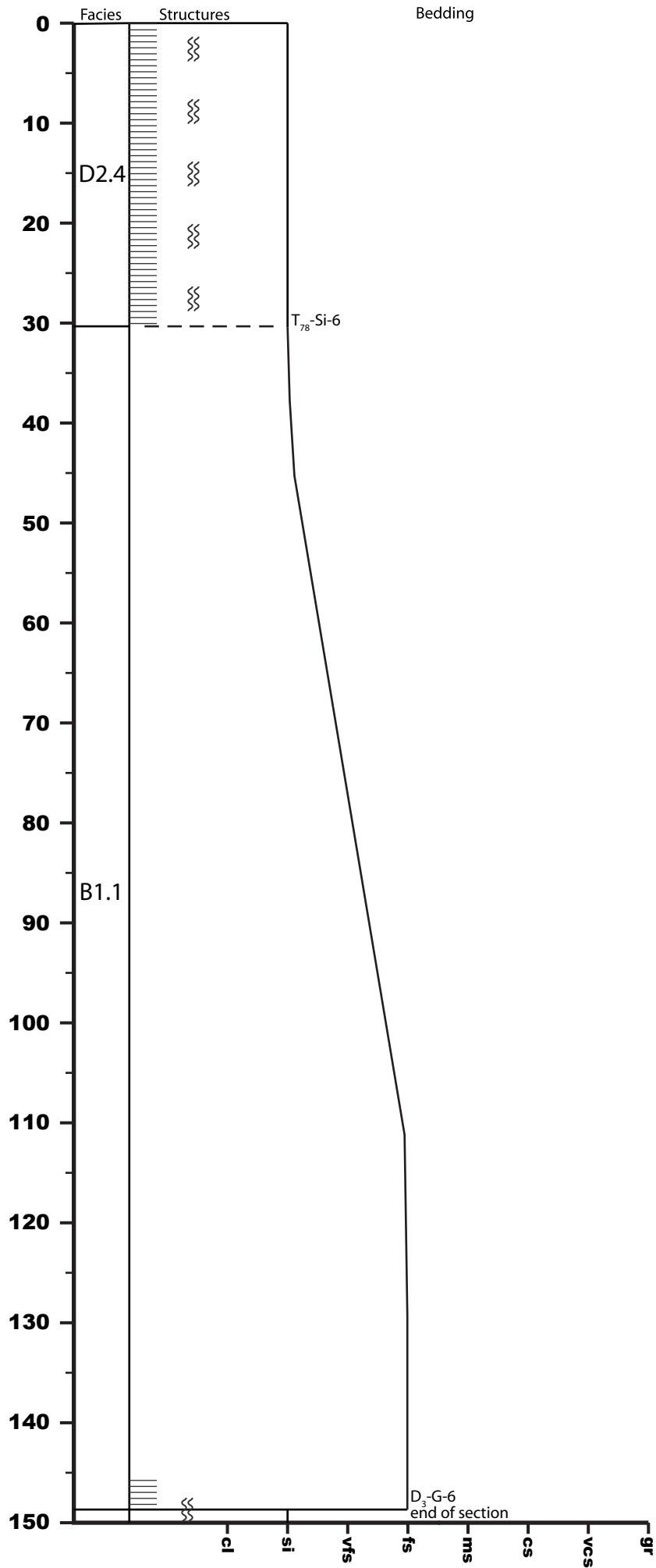

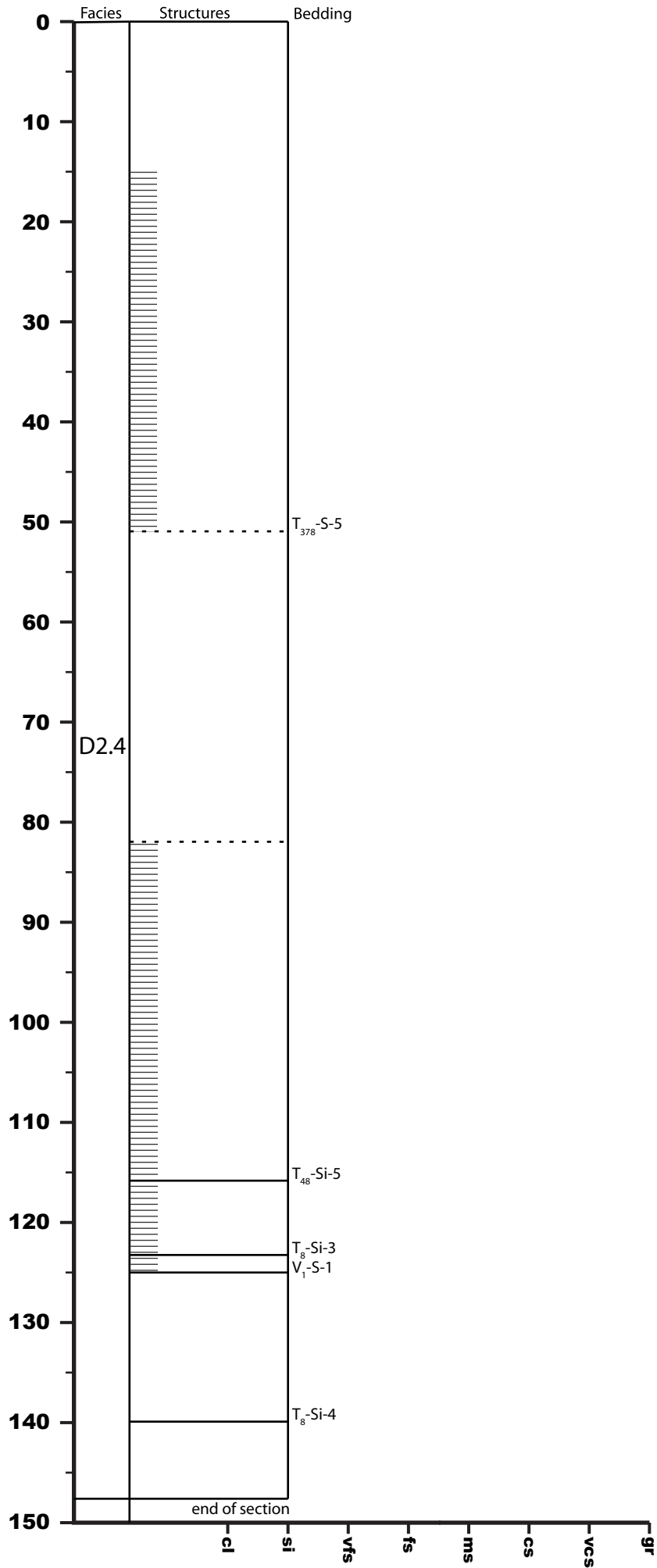

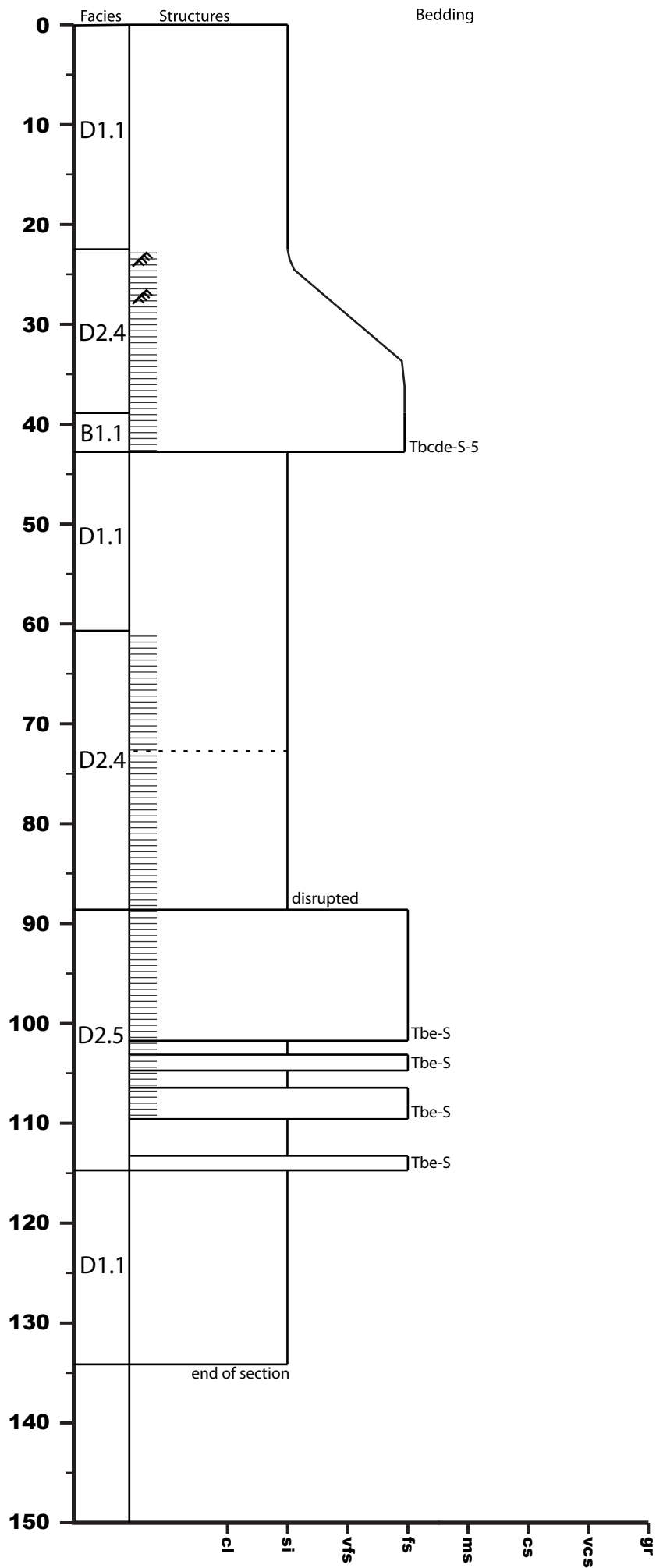

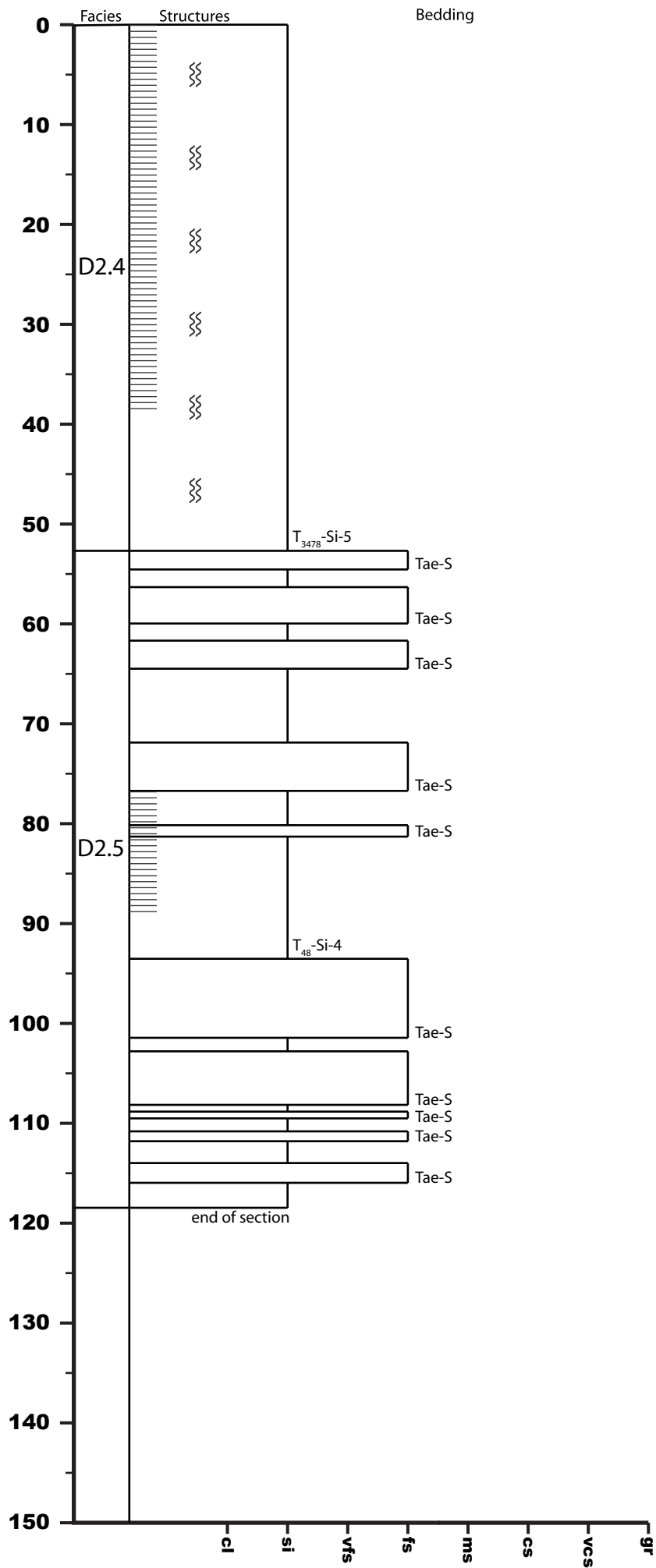

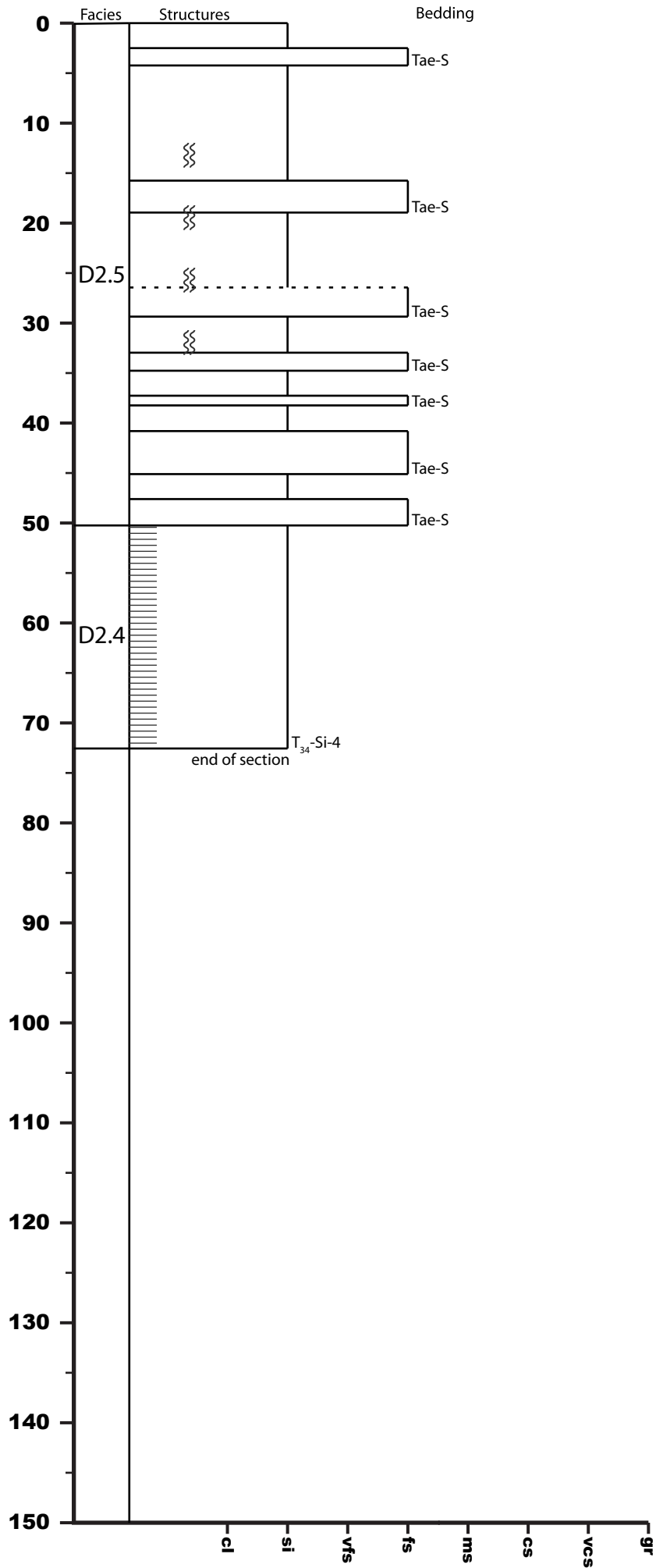



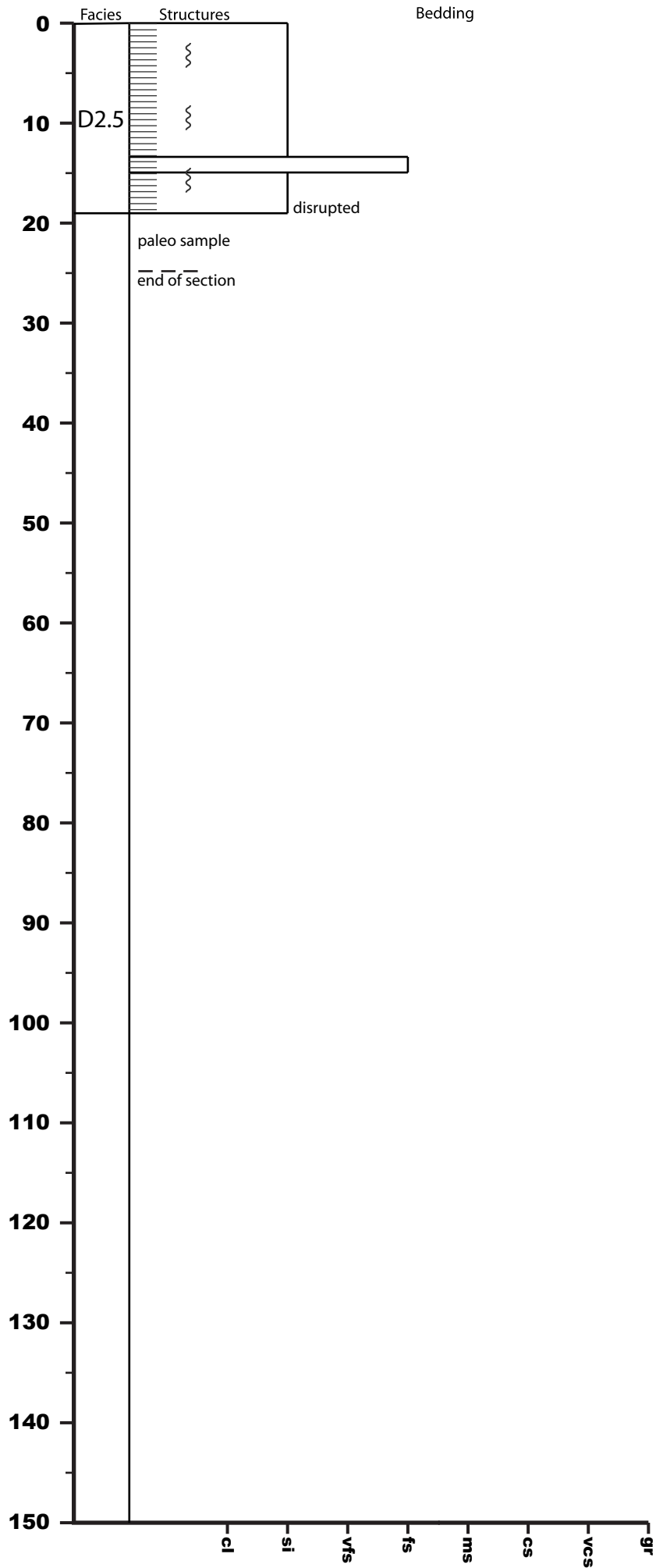

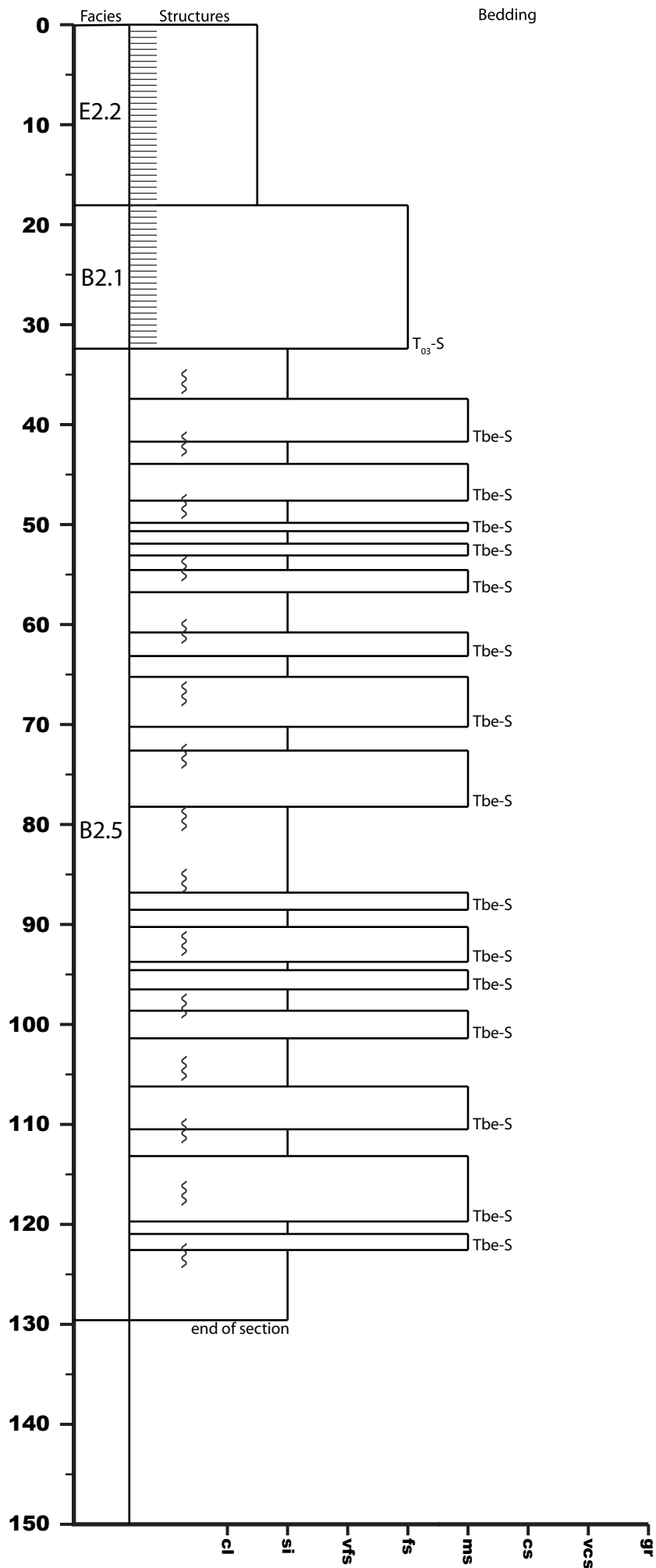

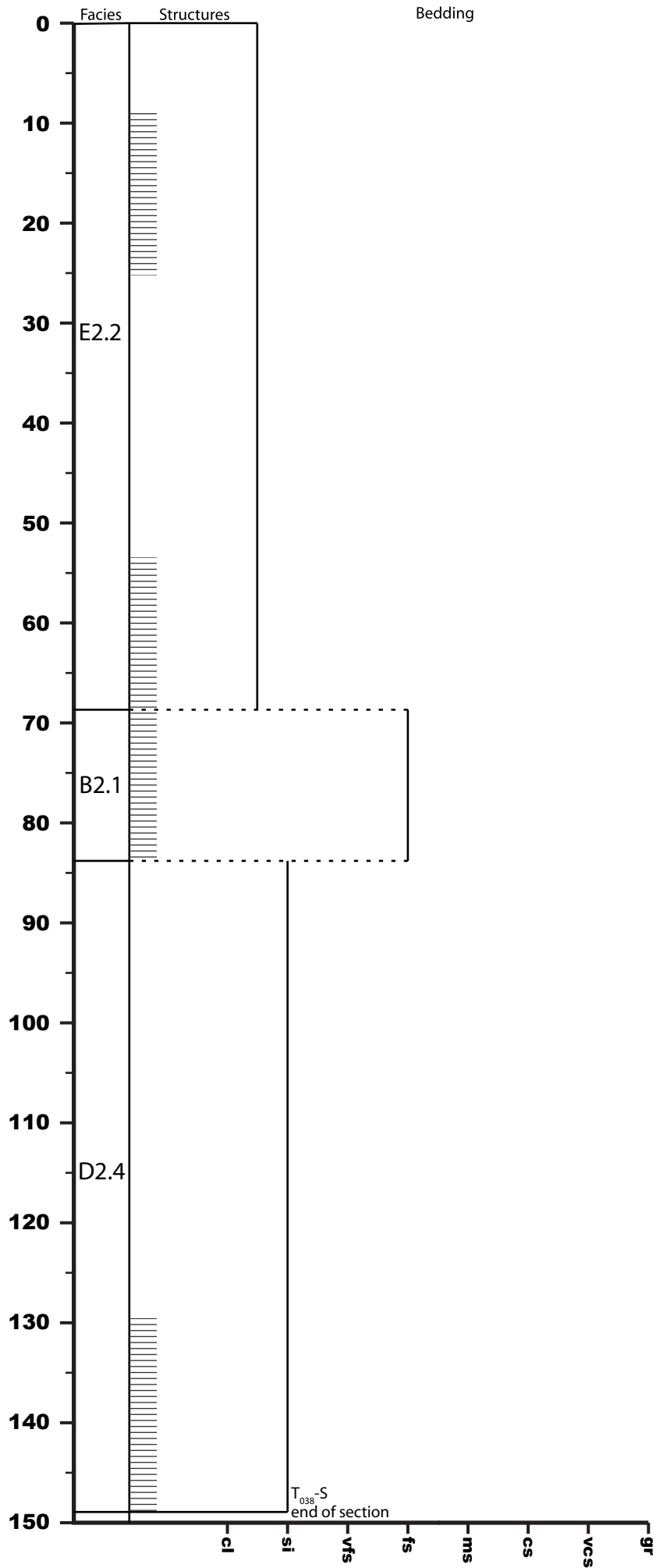

U1438D-69R-3

861.8 - 863.3 mbsf

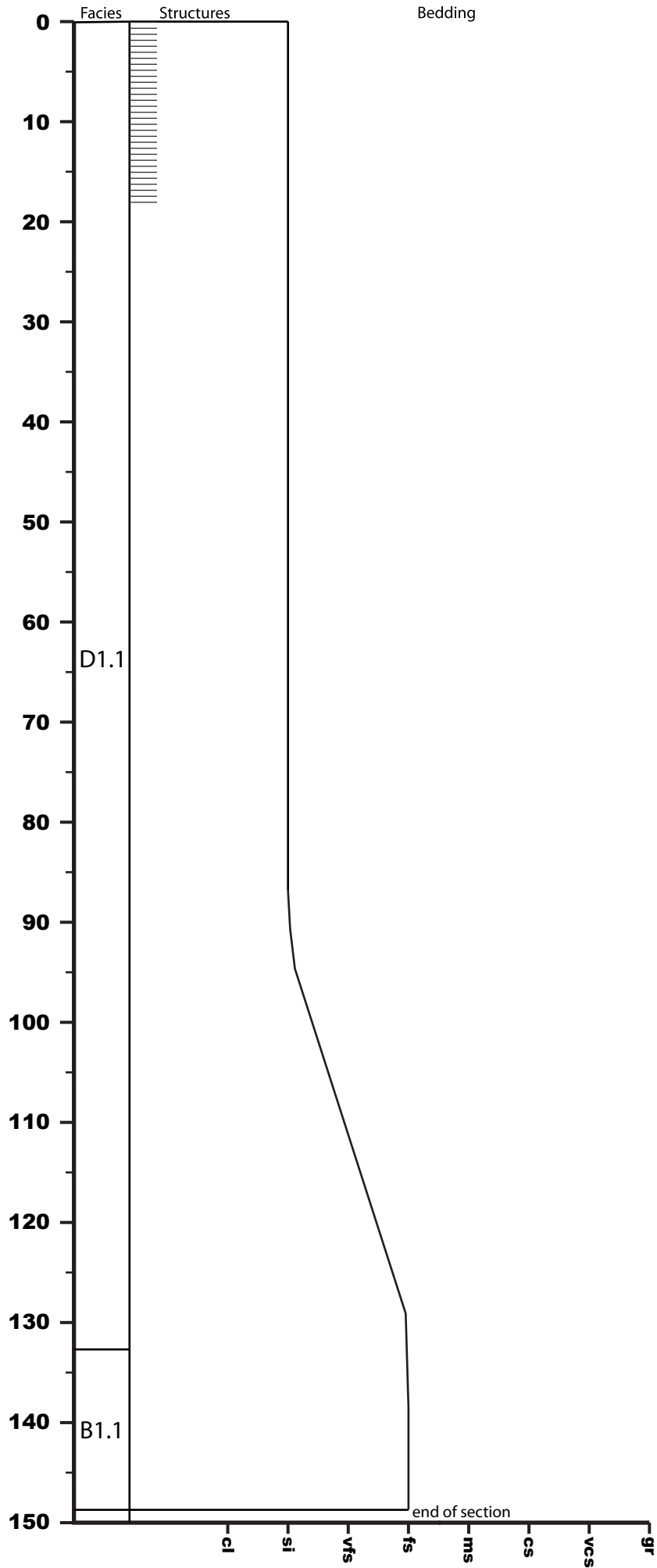

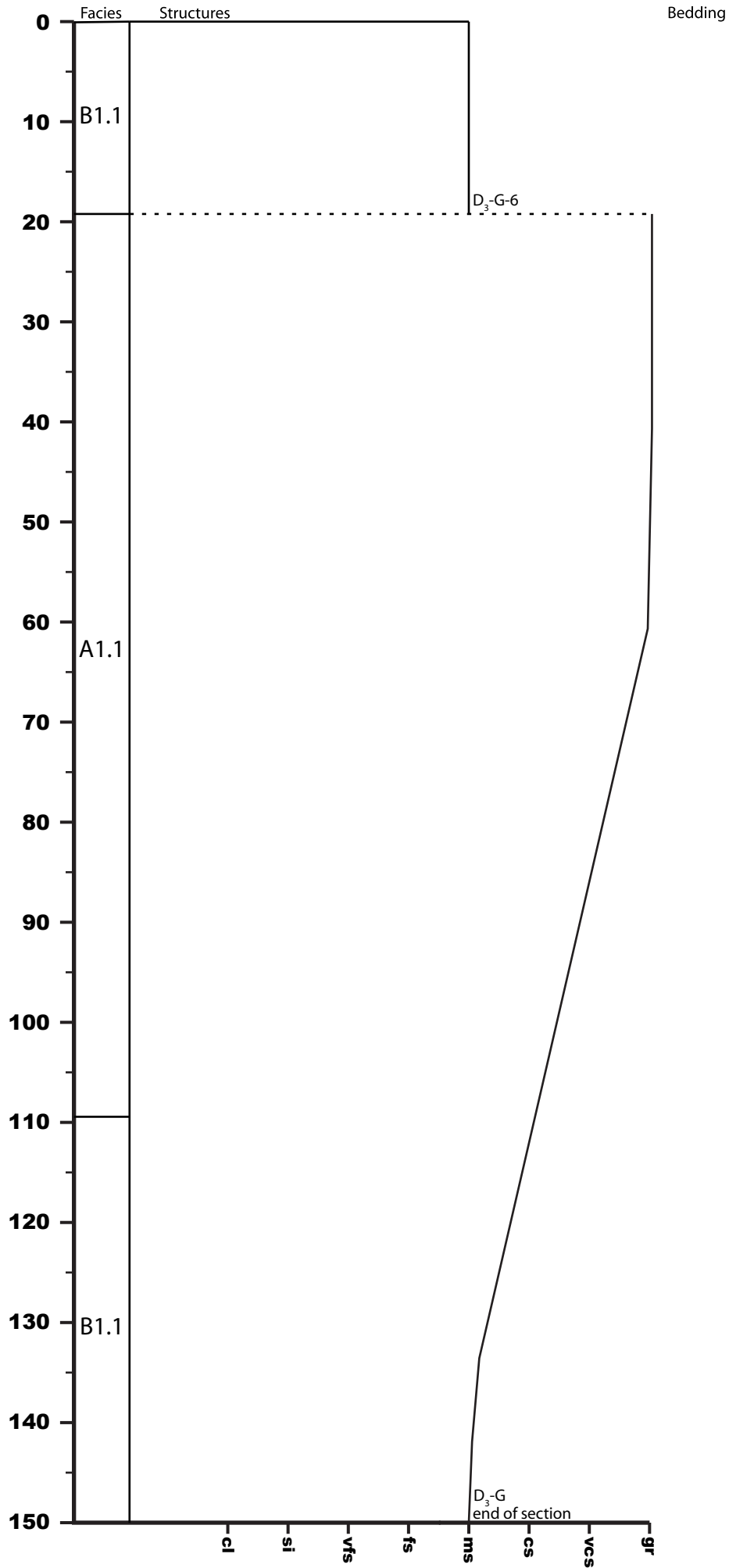

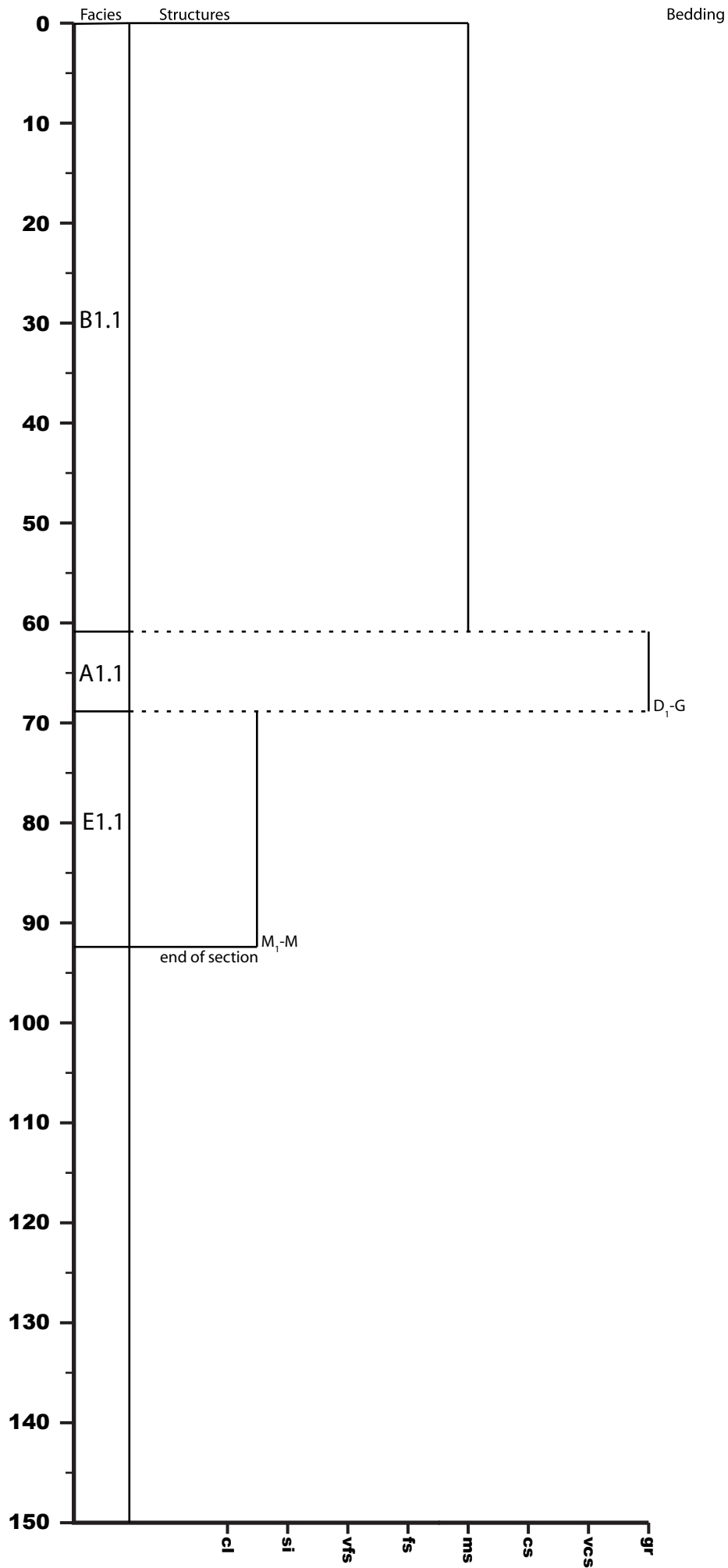

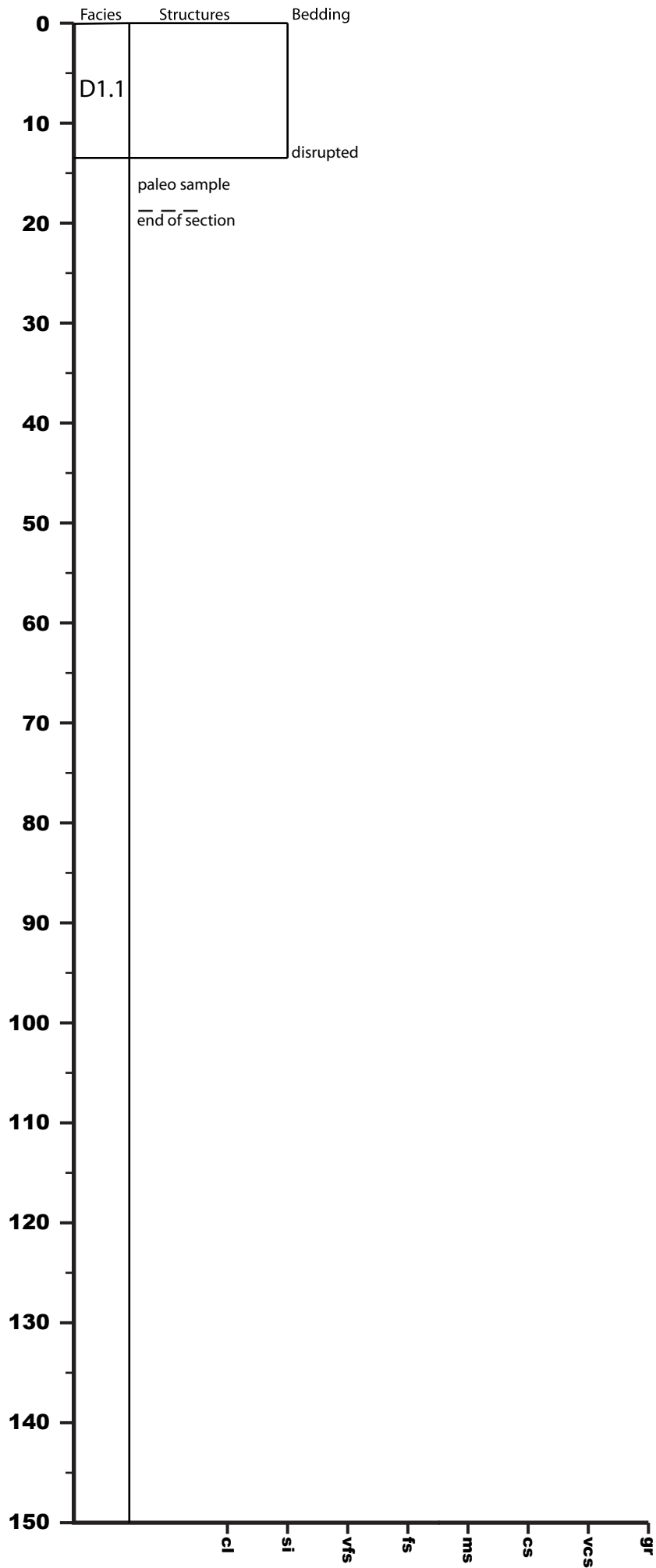

U1438D-70R-1

868.7 - 870.14 mbsf

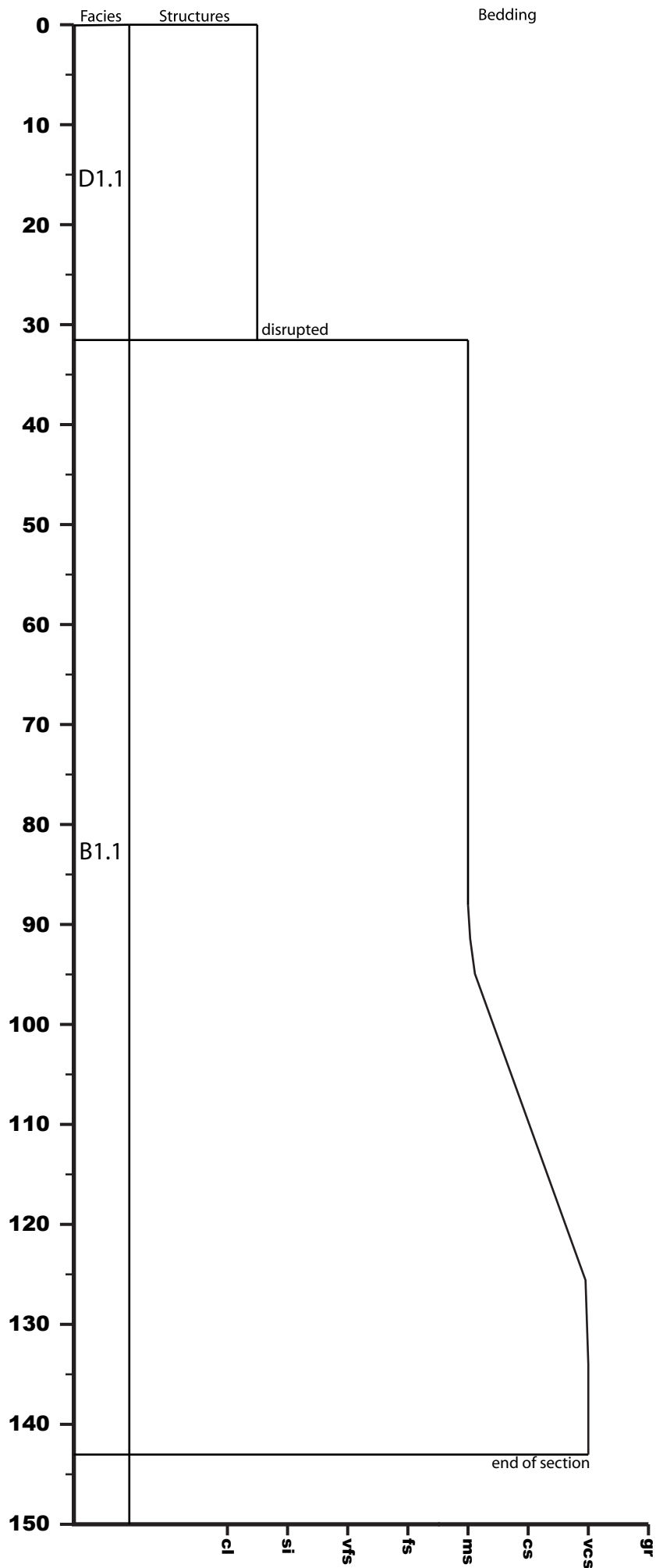



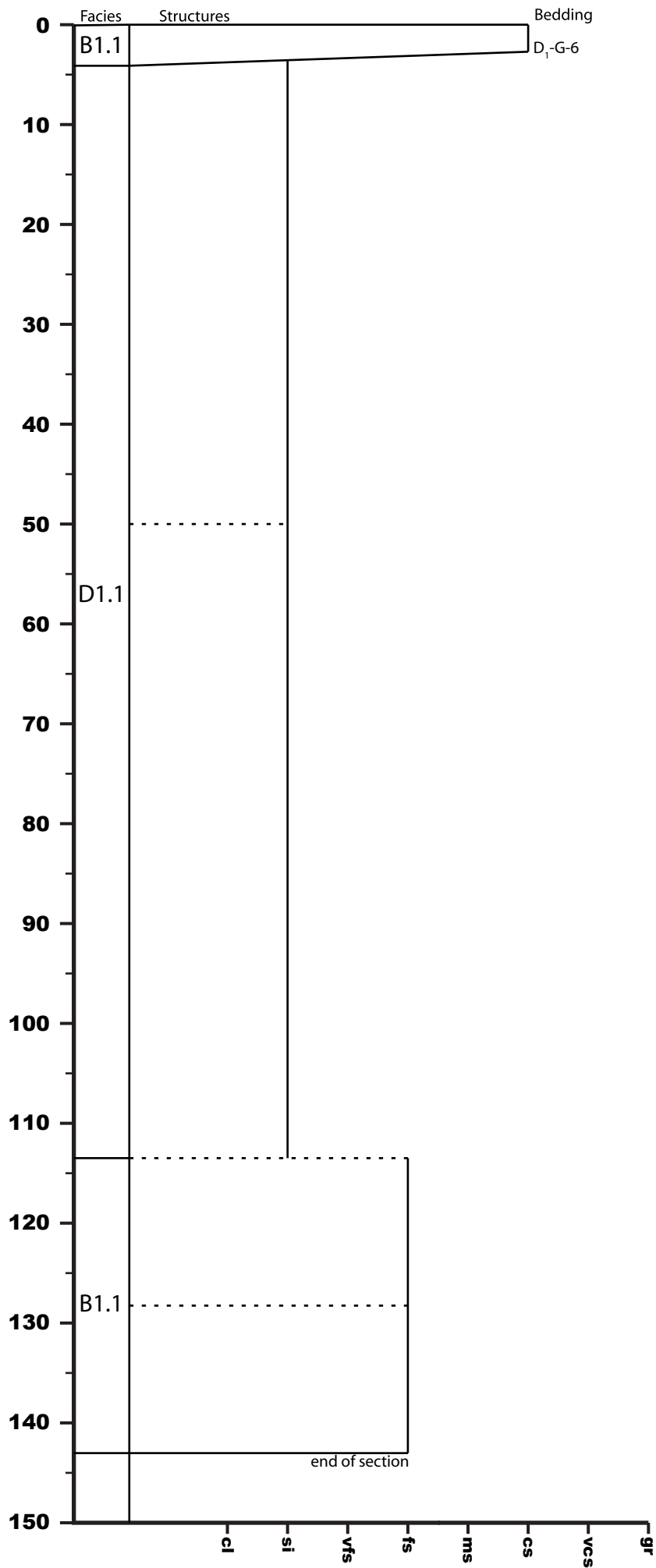

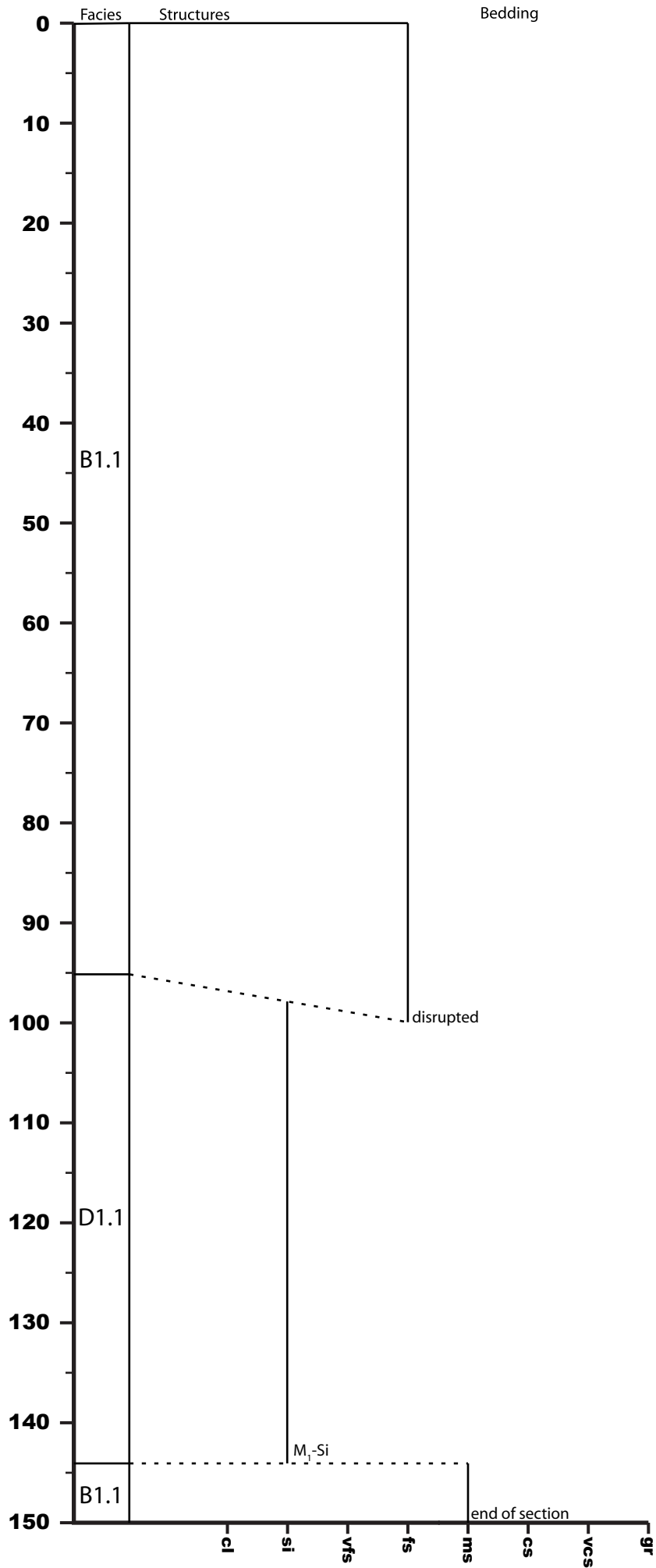

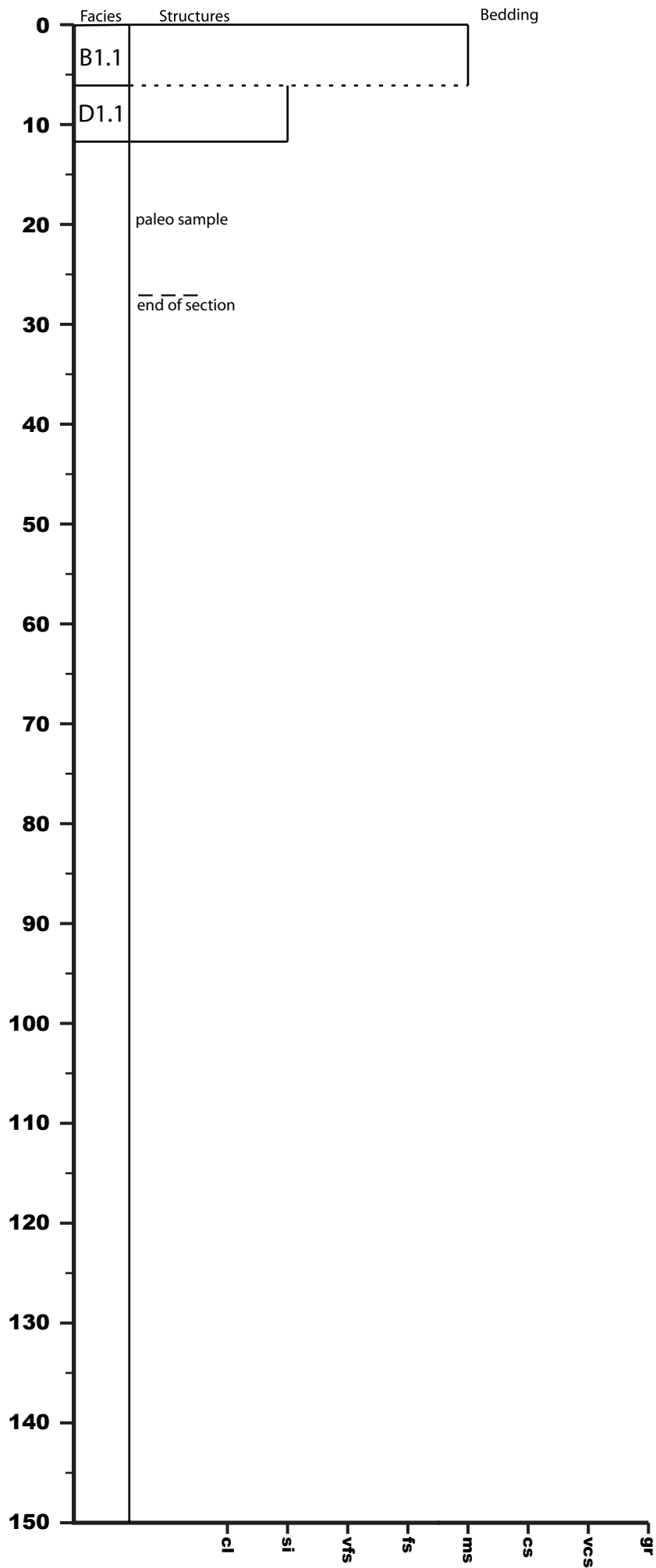

U1438D-71R-1

878.4 - 879.76 mbsf

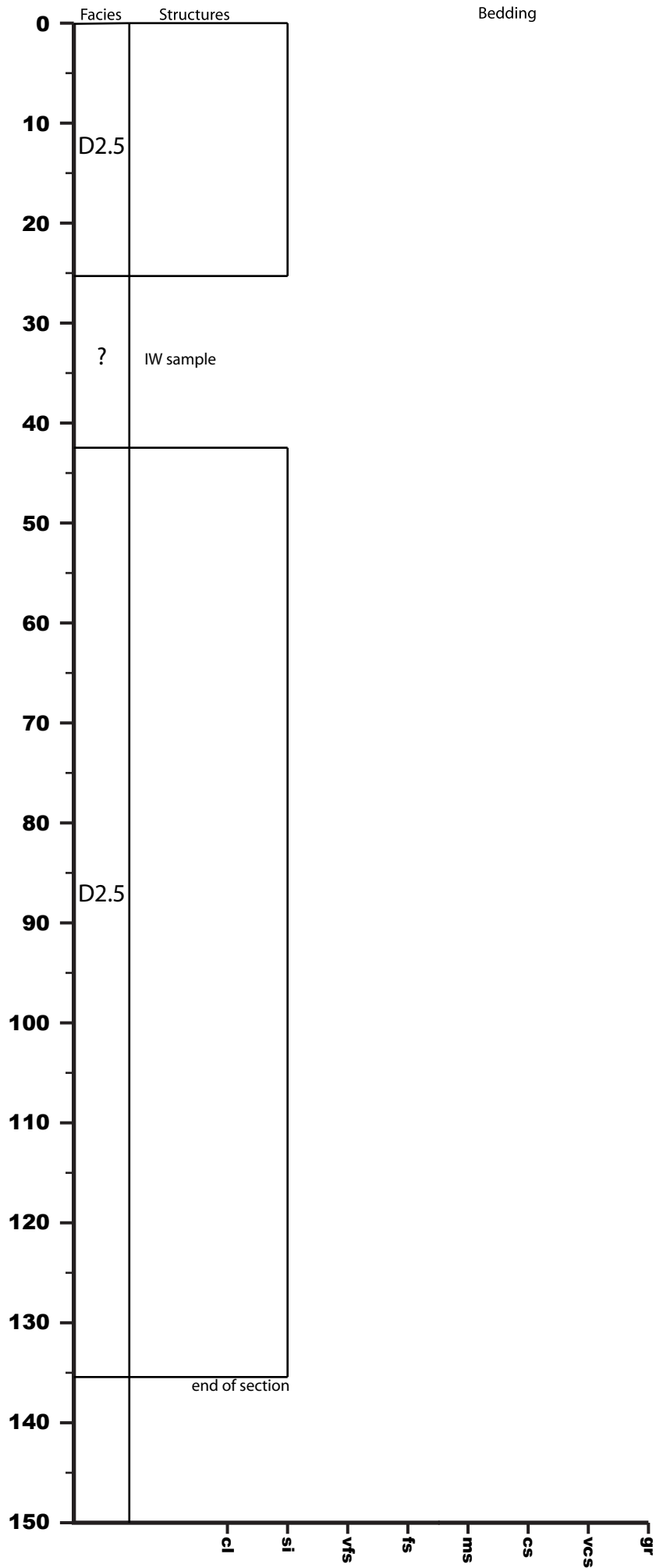

U1438D-71R-2

879.76 - 881.26 mbsf

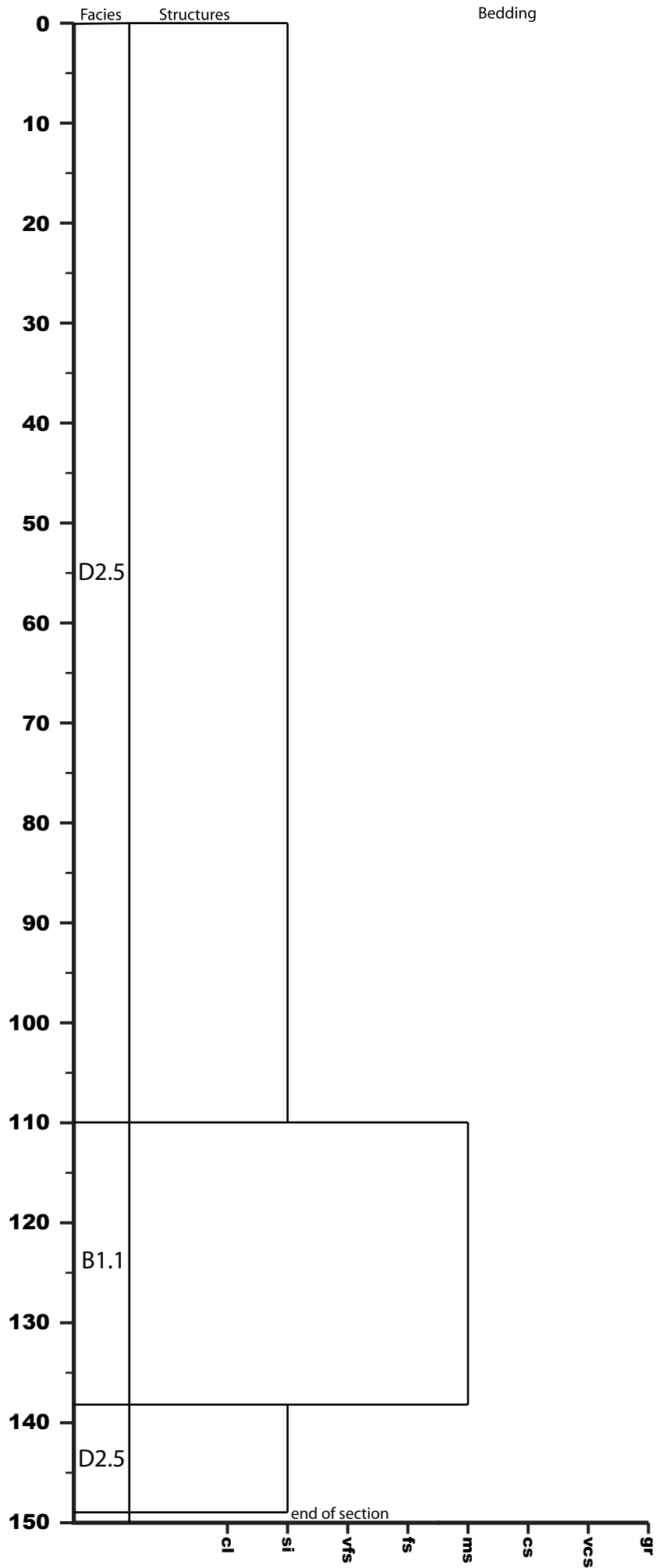

U1438D-71R-3

881.26 - 882.32 mbsf

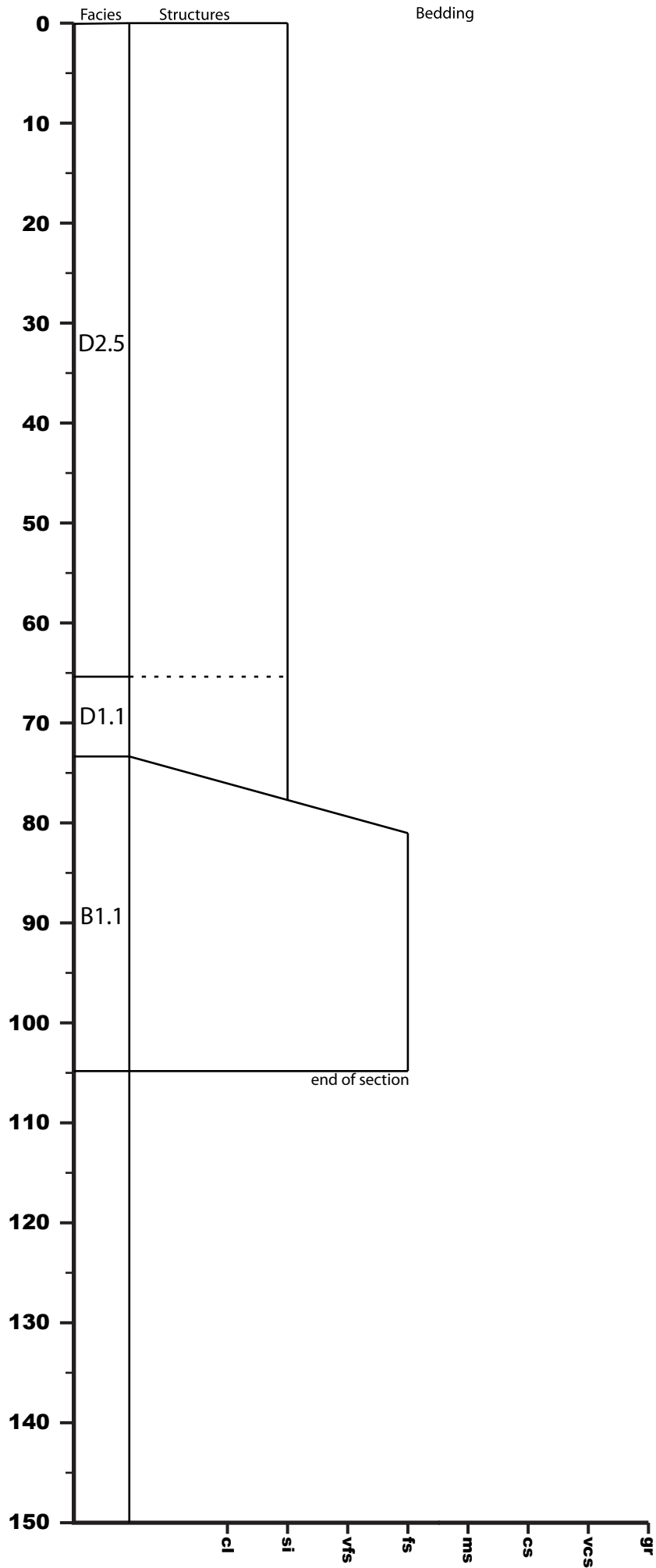

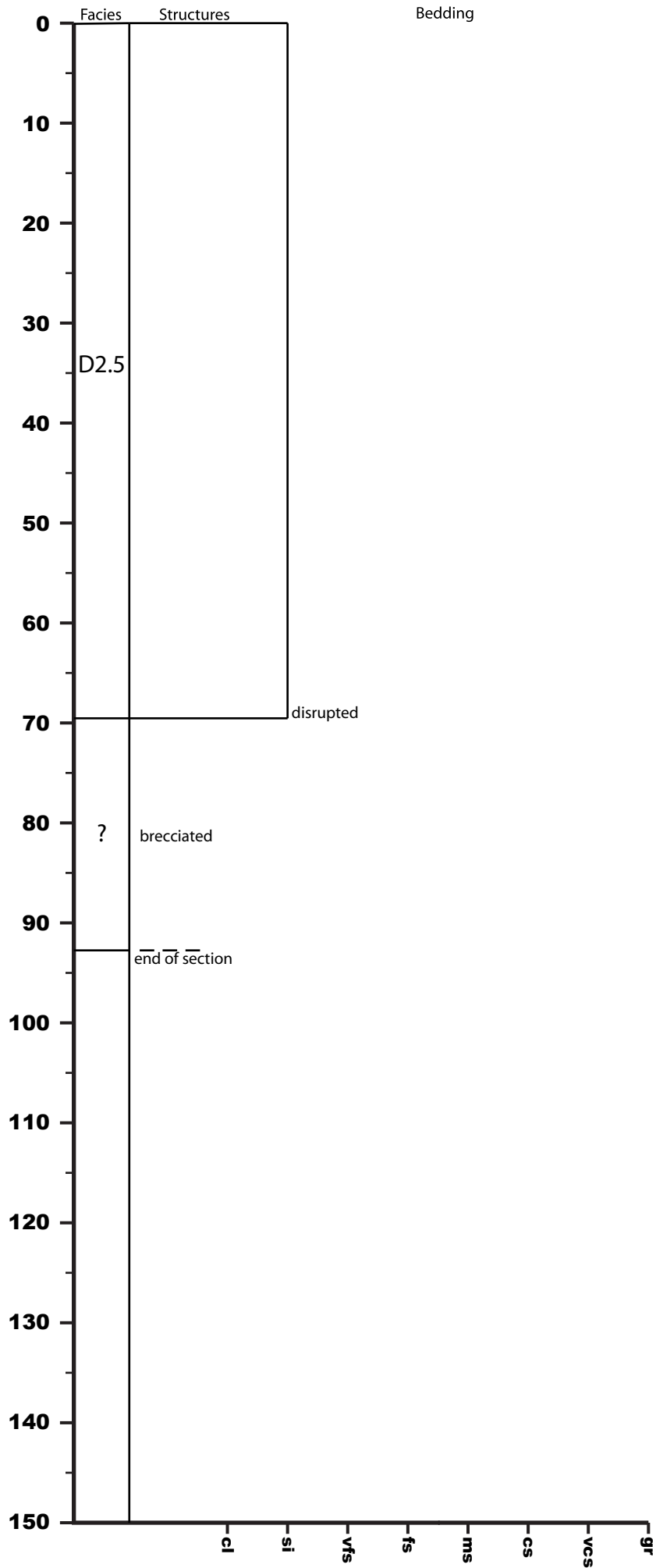

U1438D-71R-CC

883.26 - 883.46 mbsf

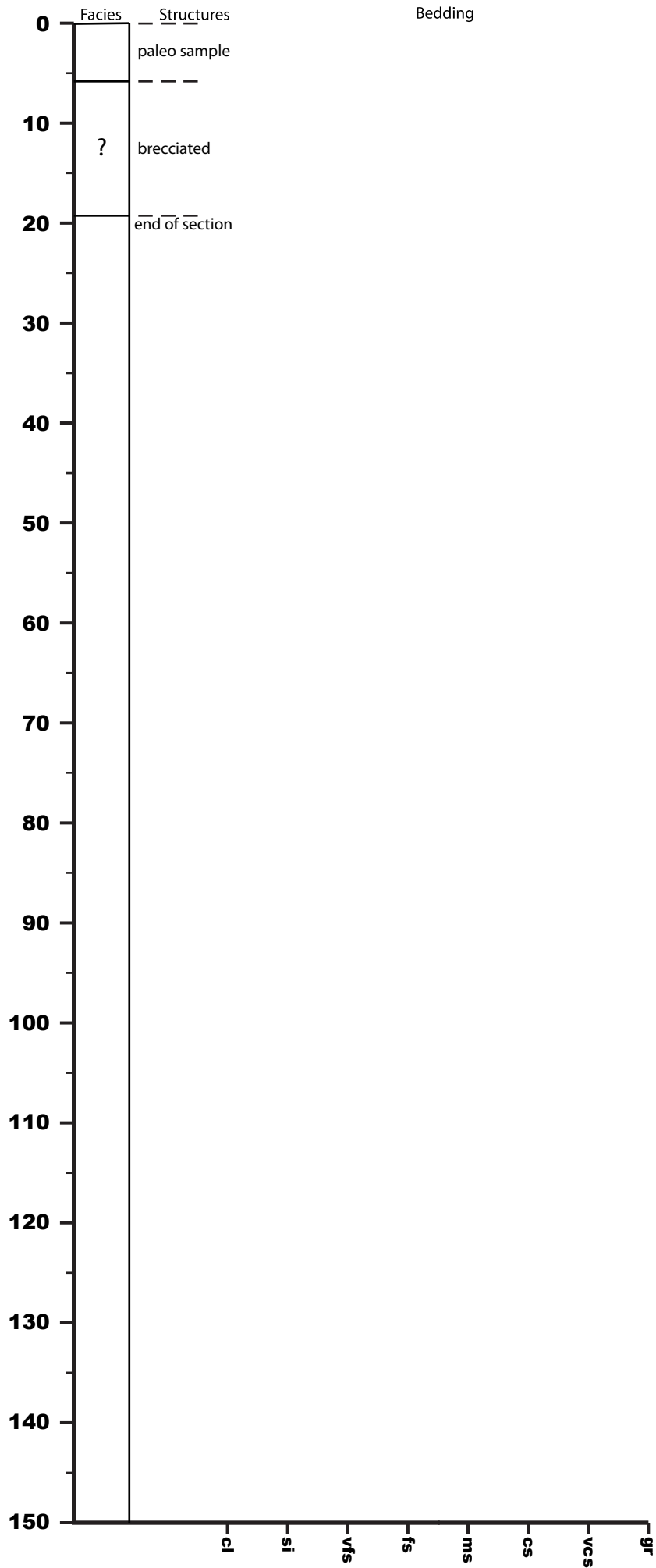



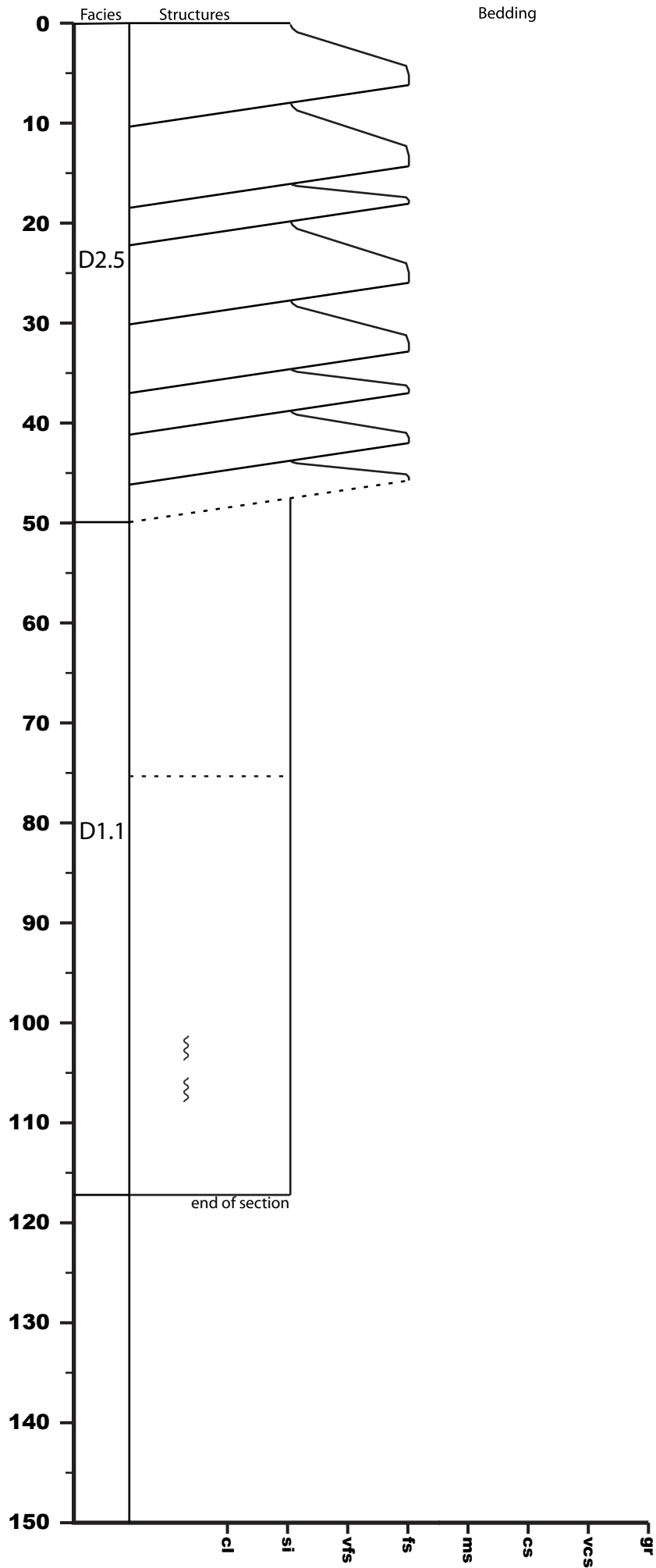

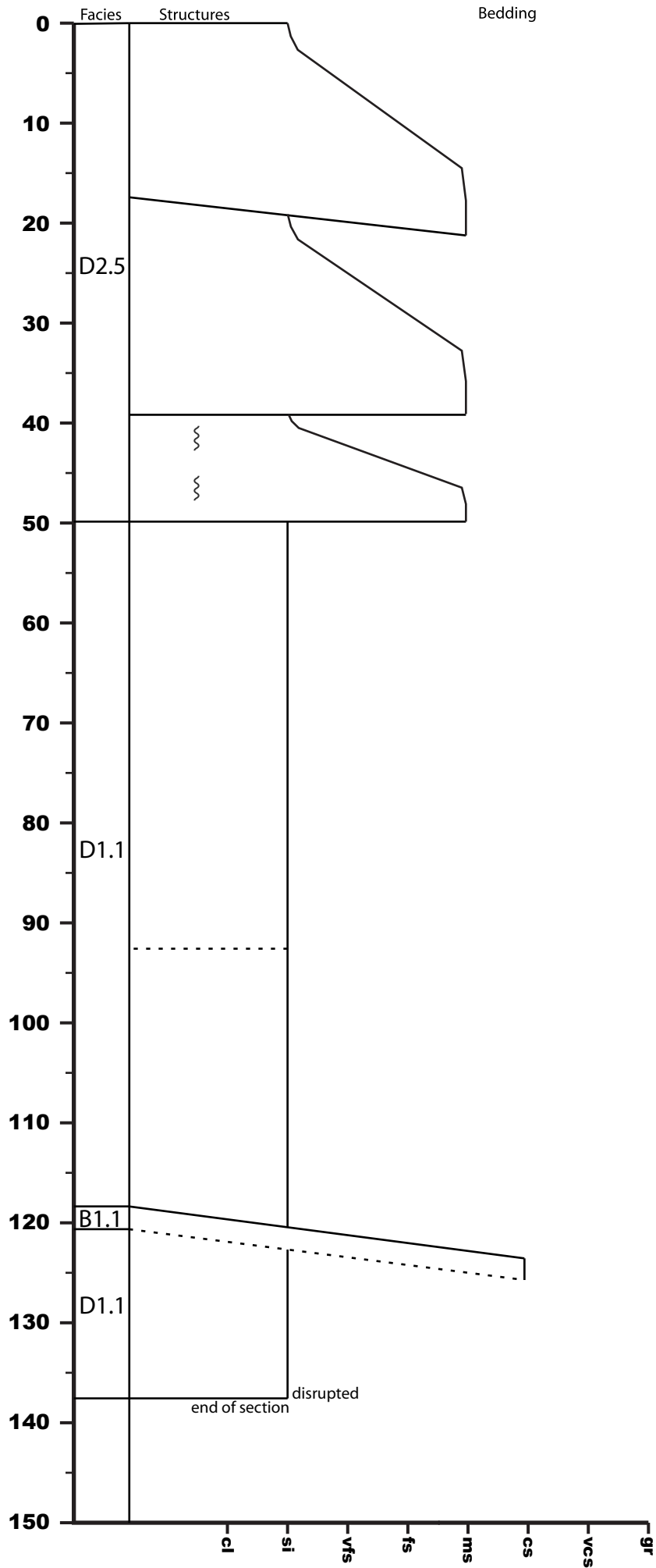

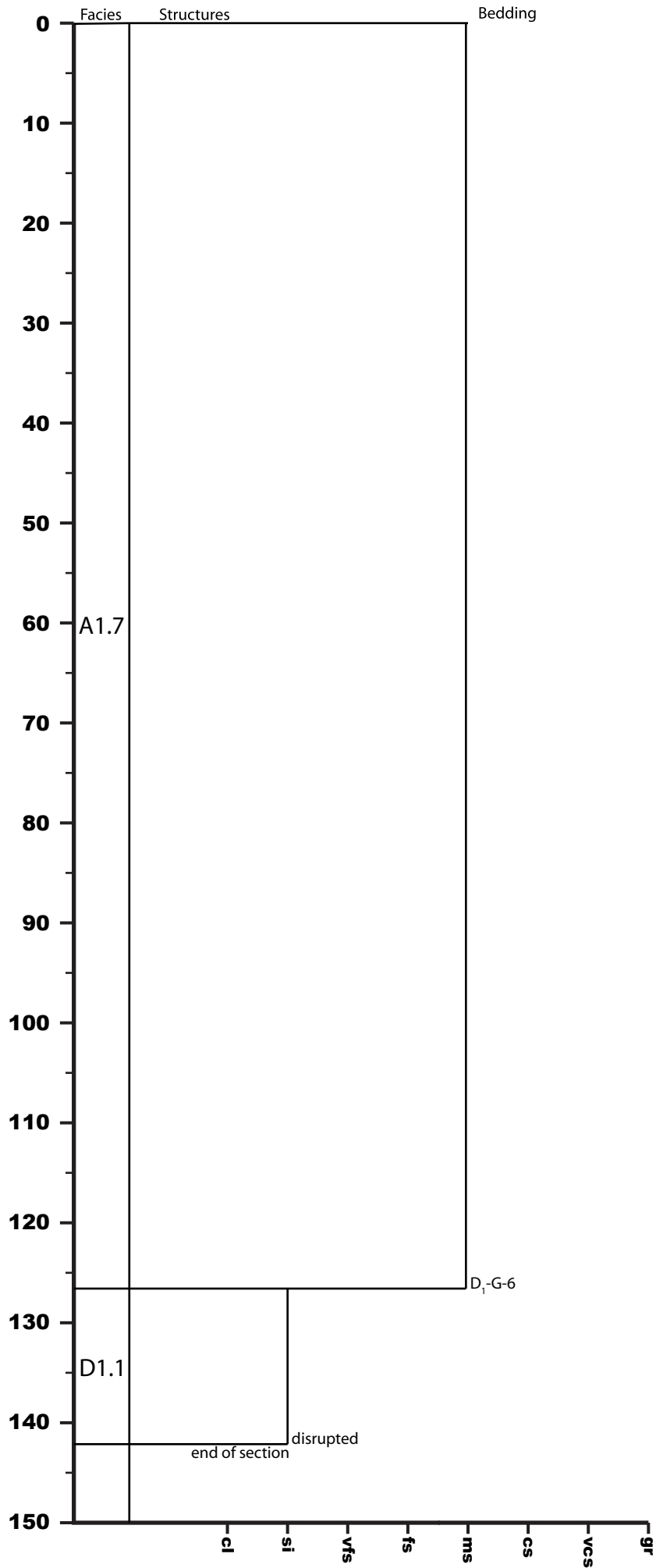

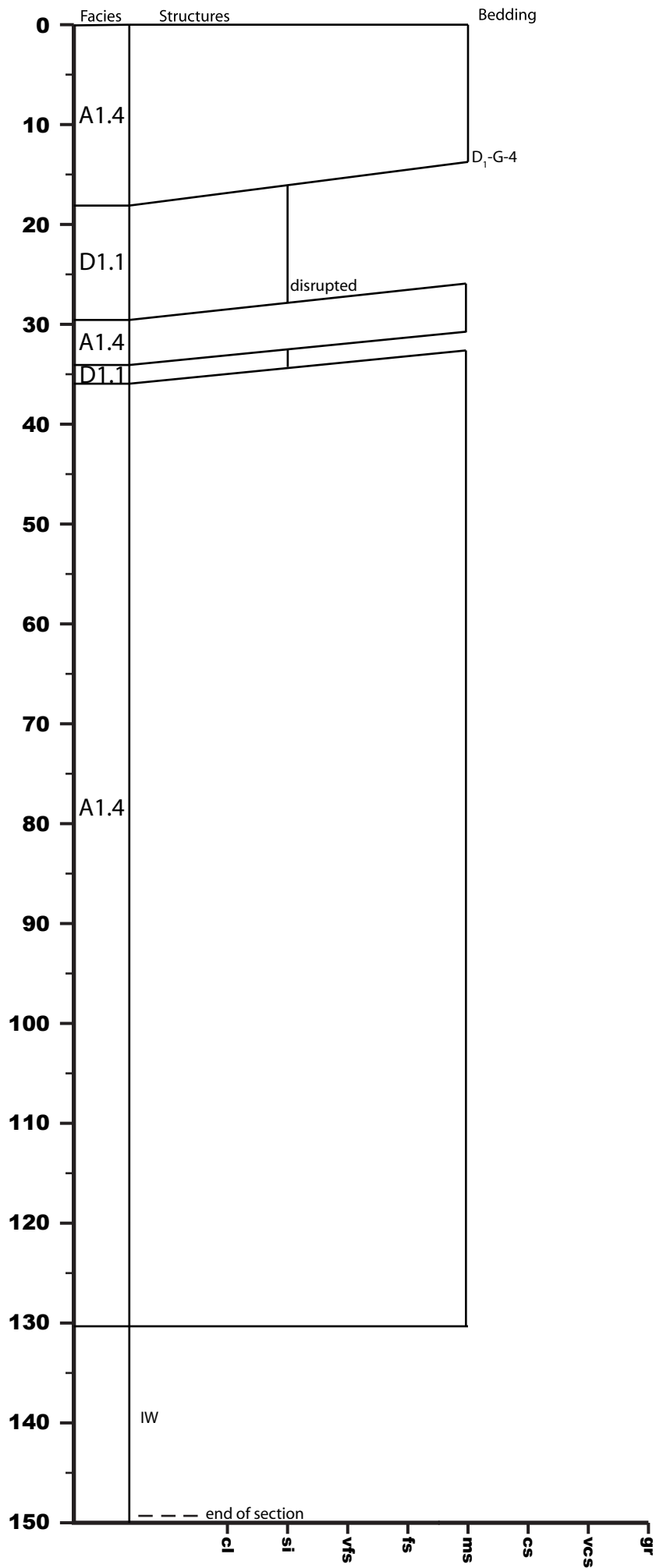

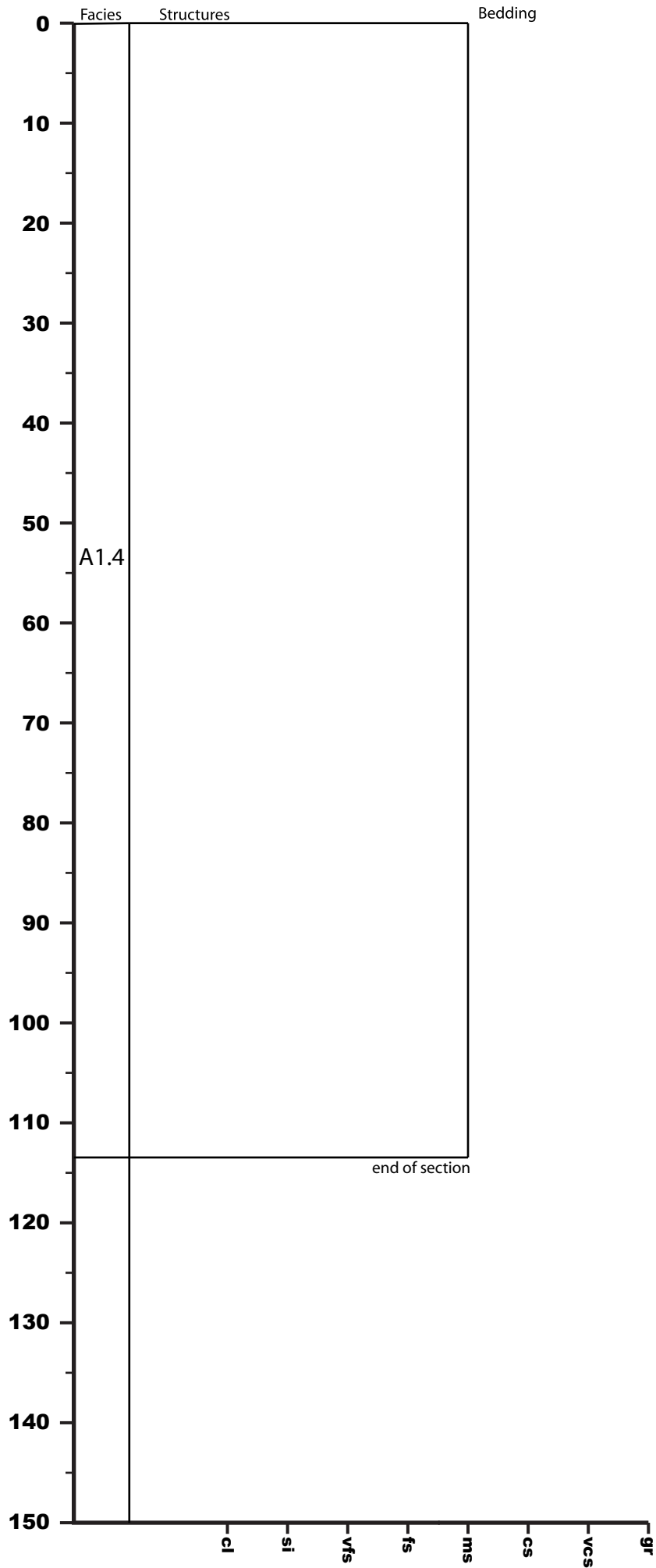

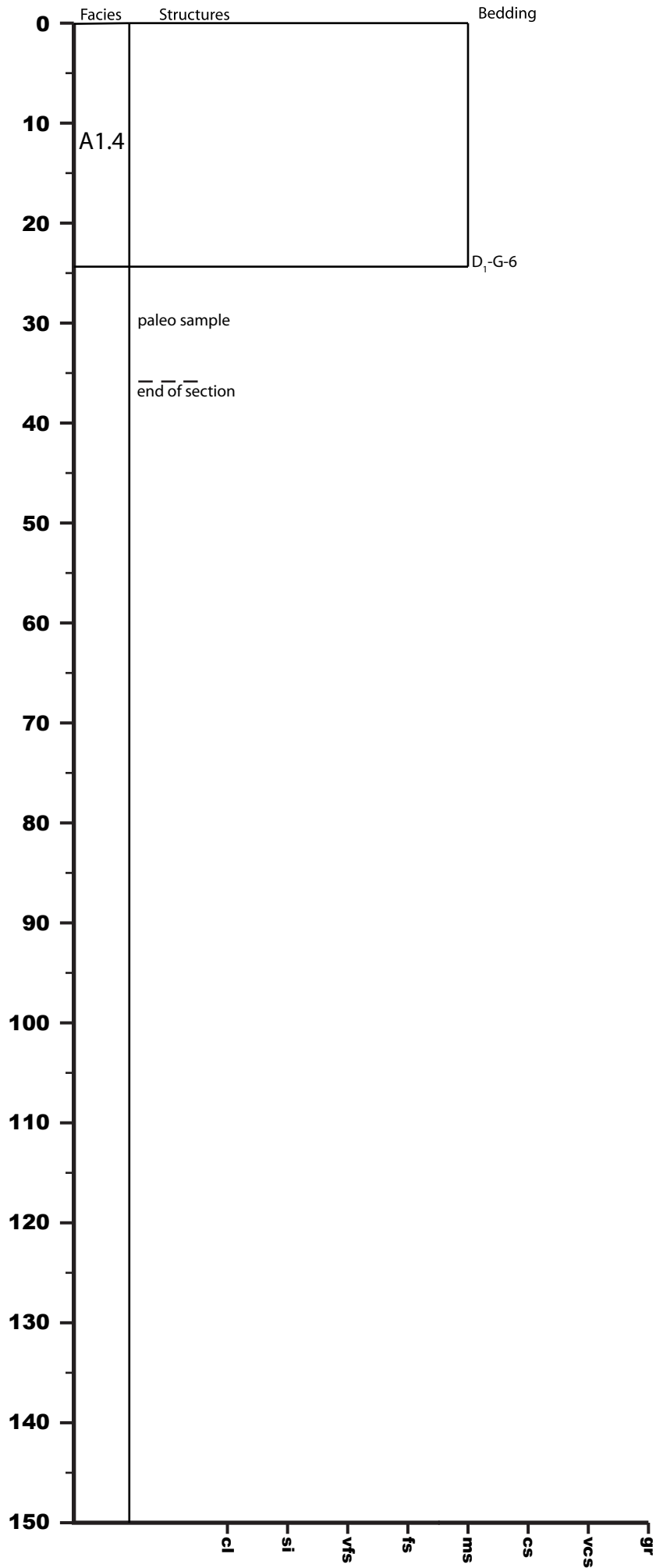

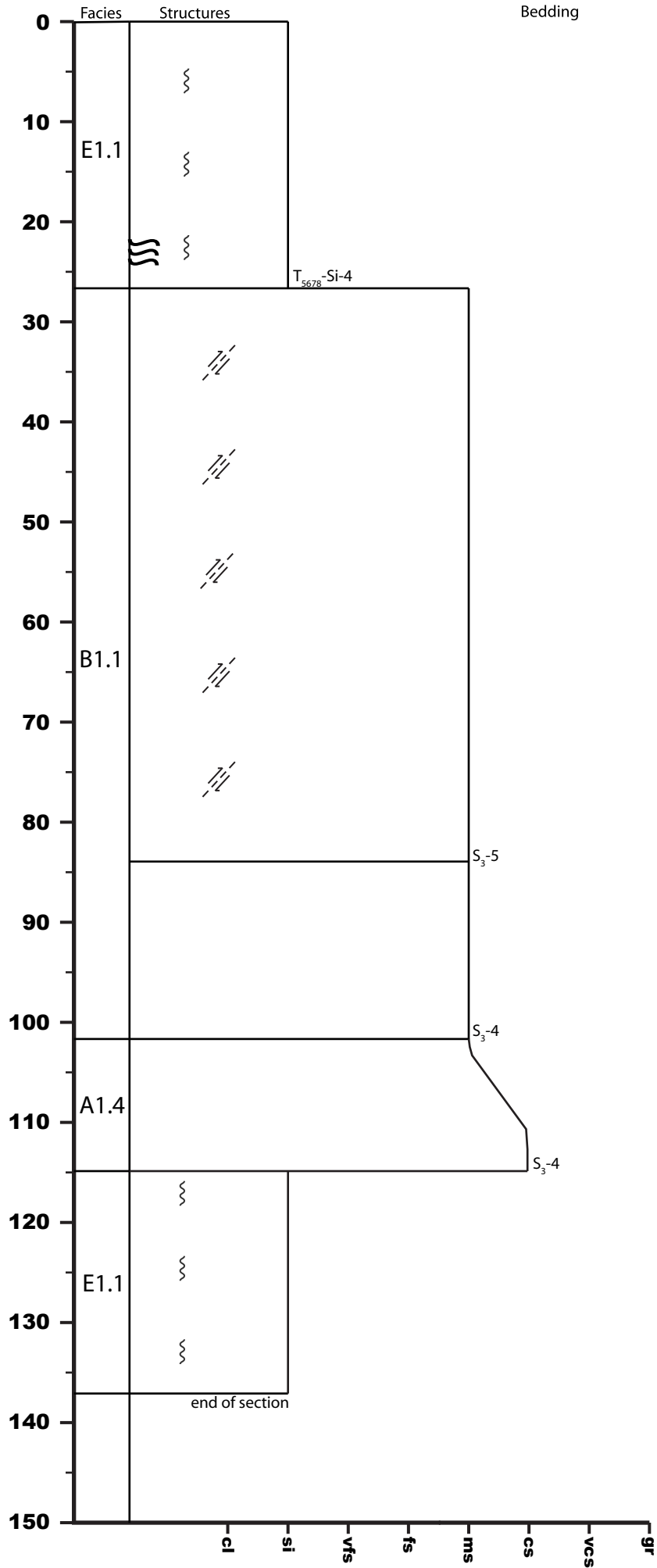

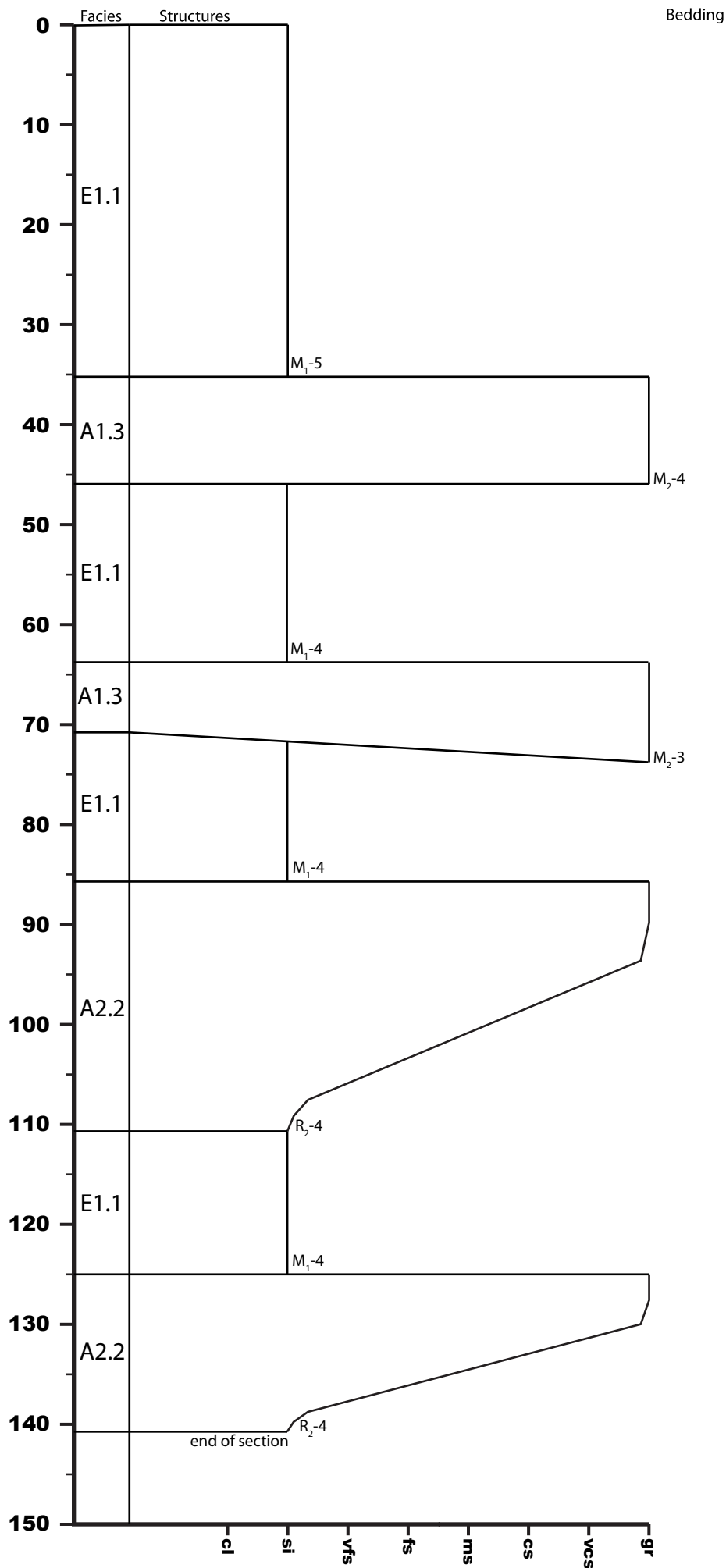



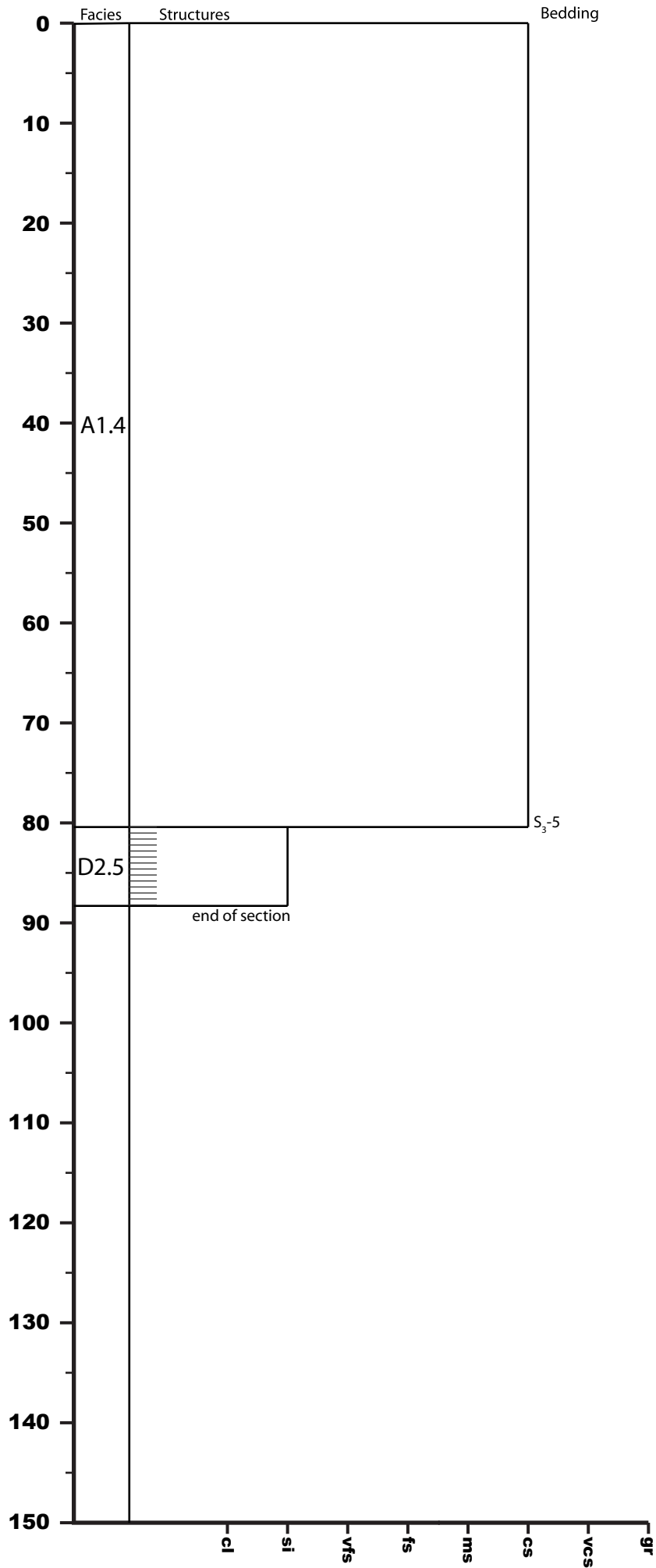

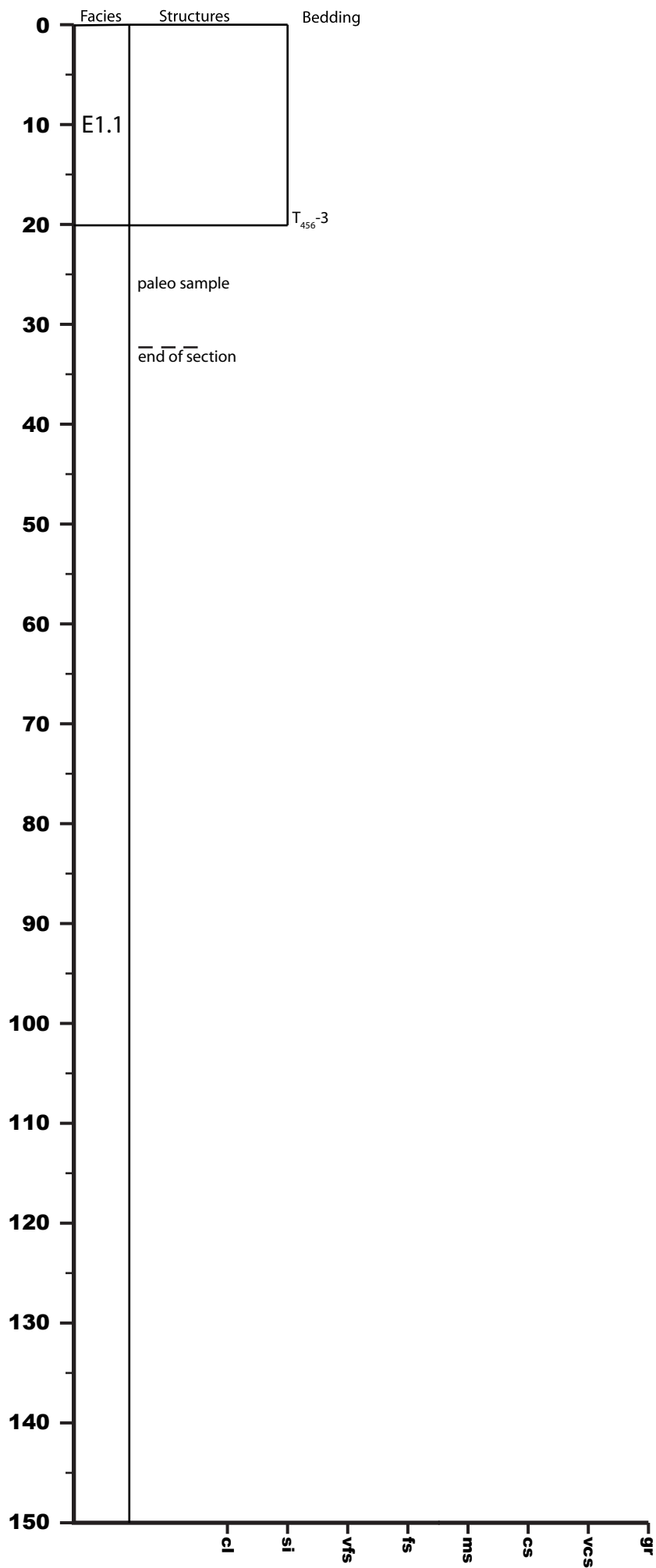

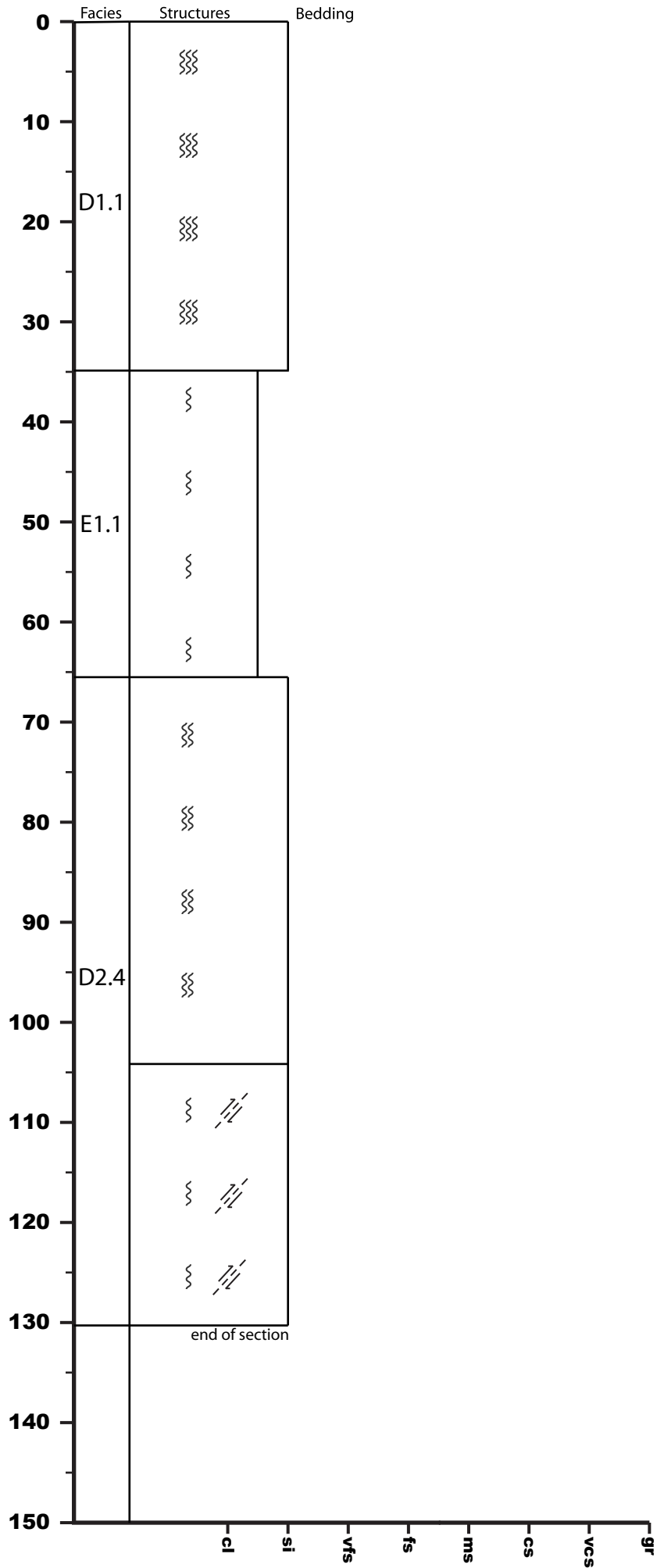

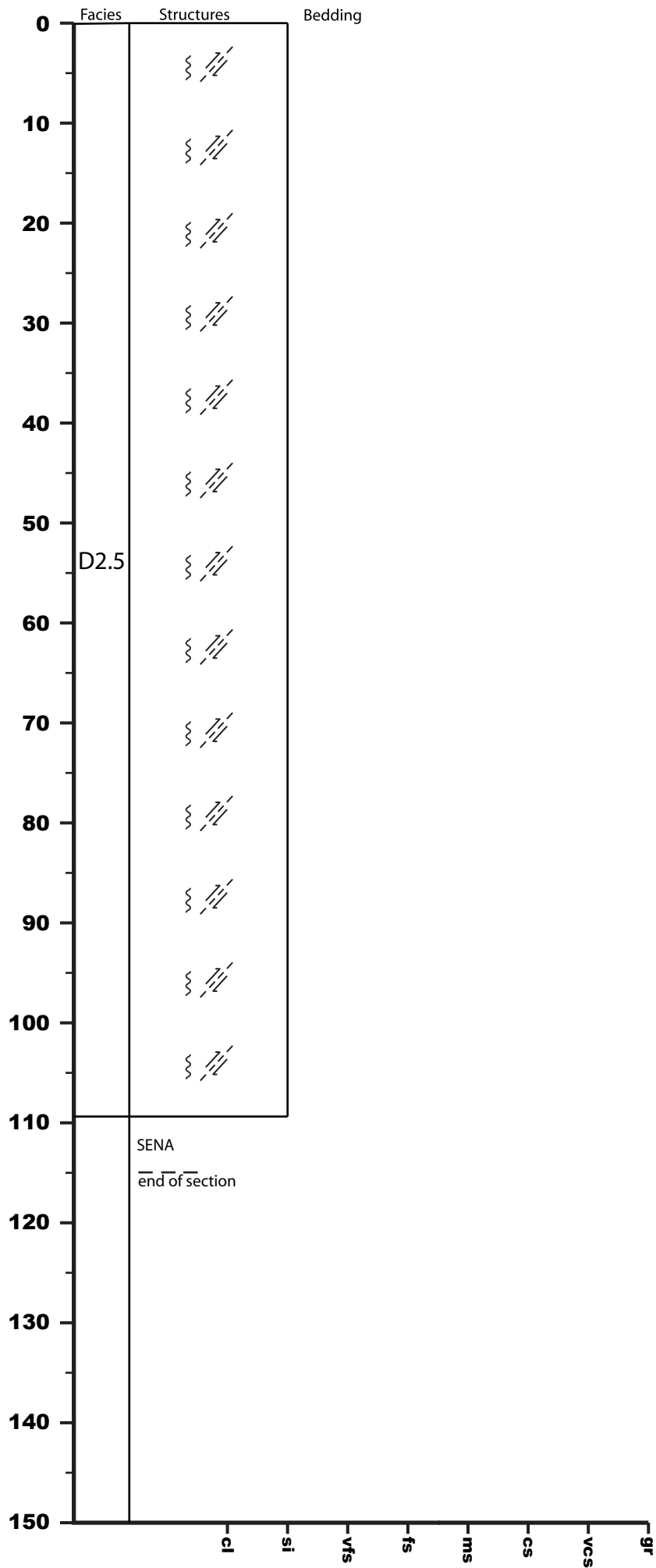

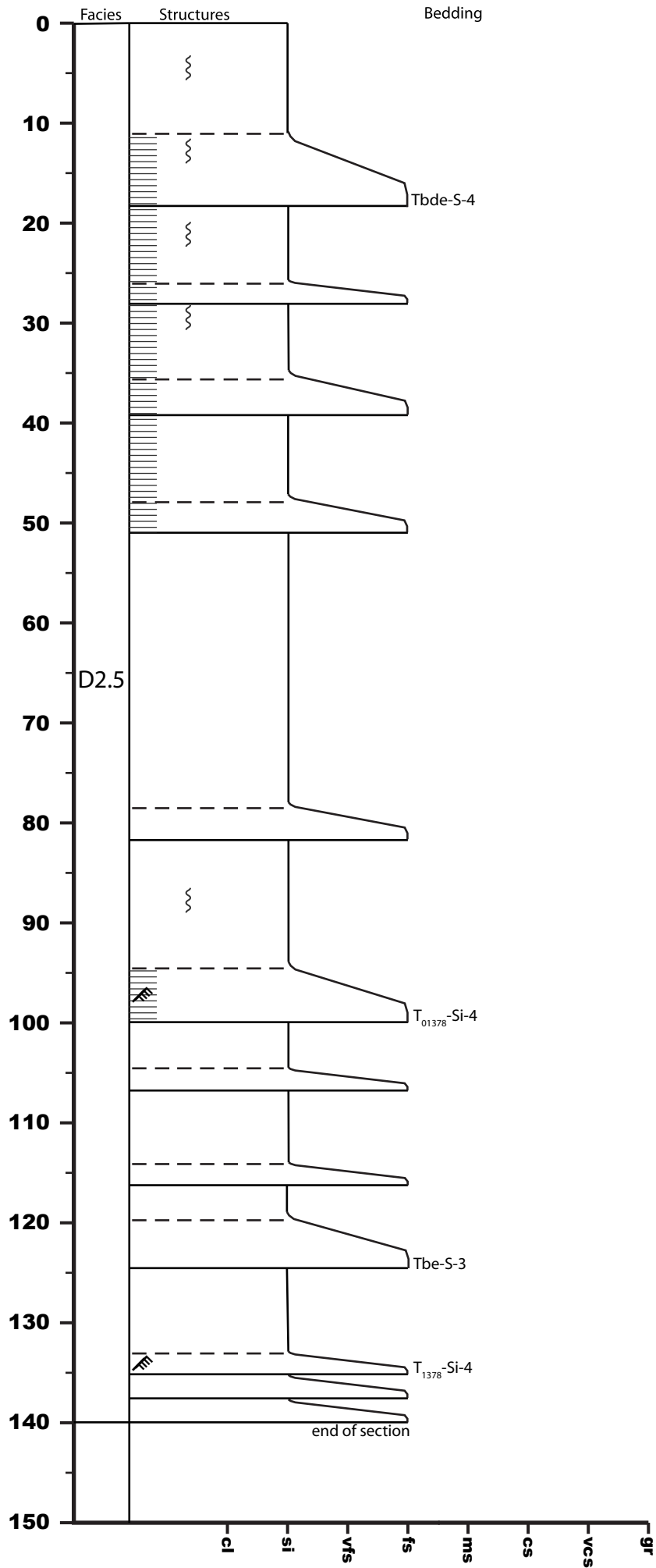

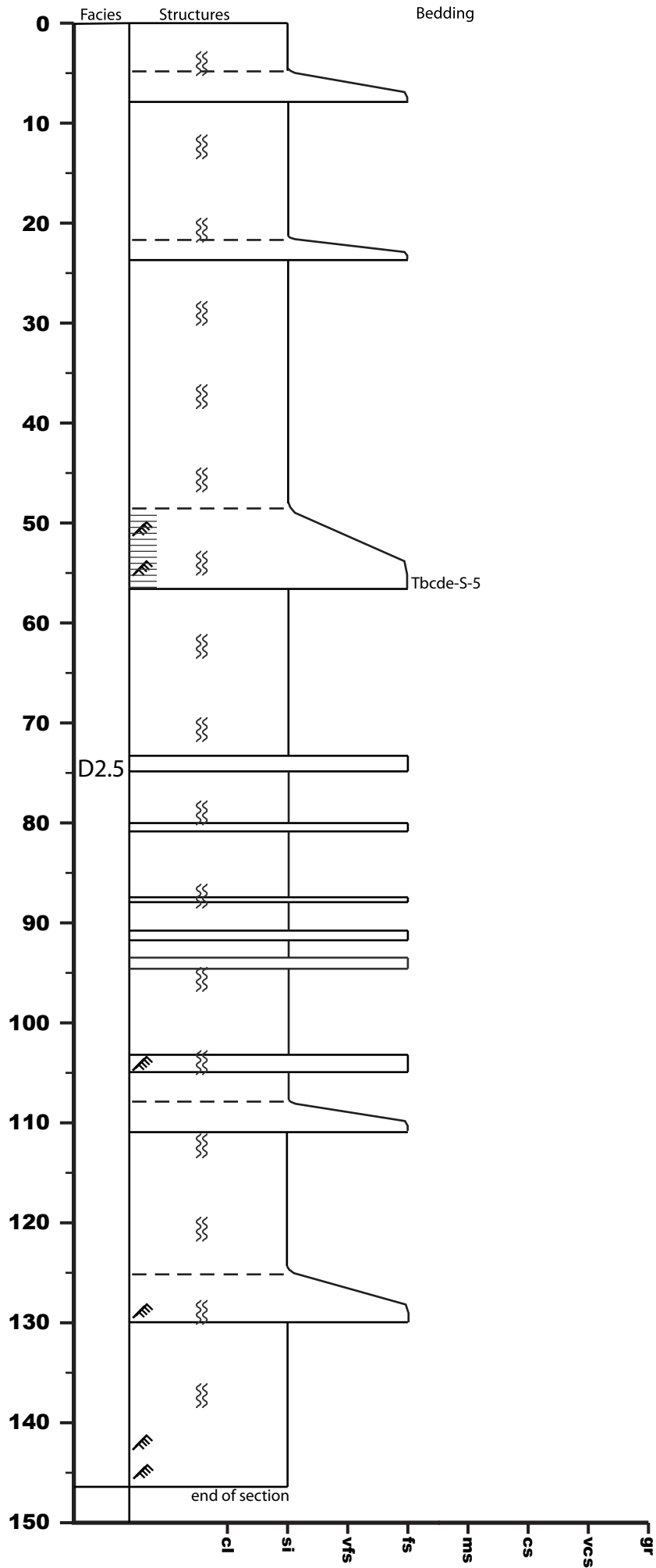

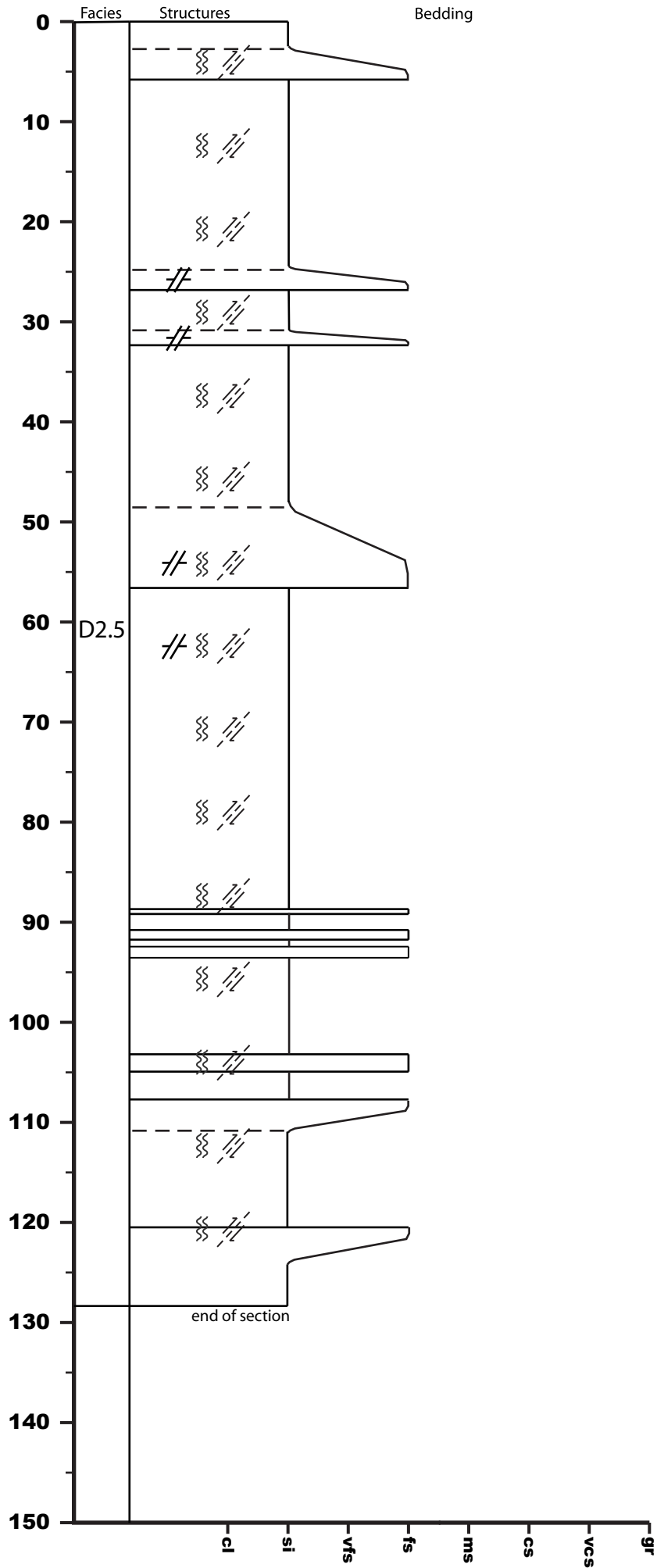

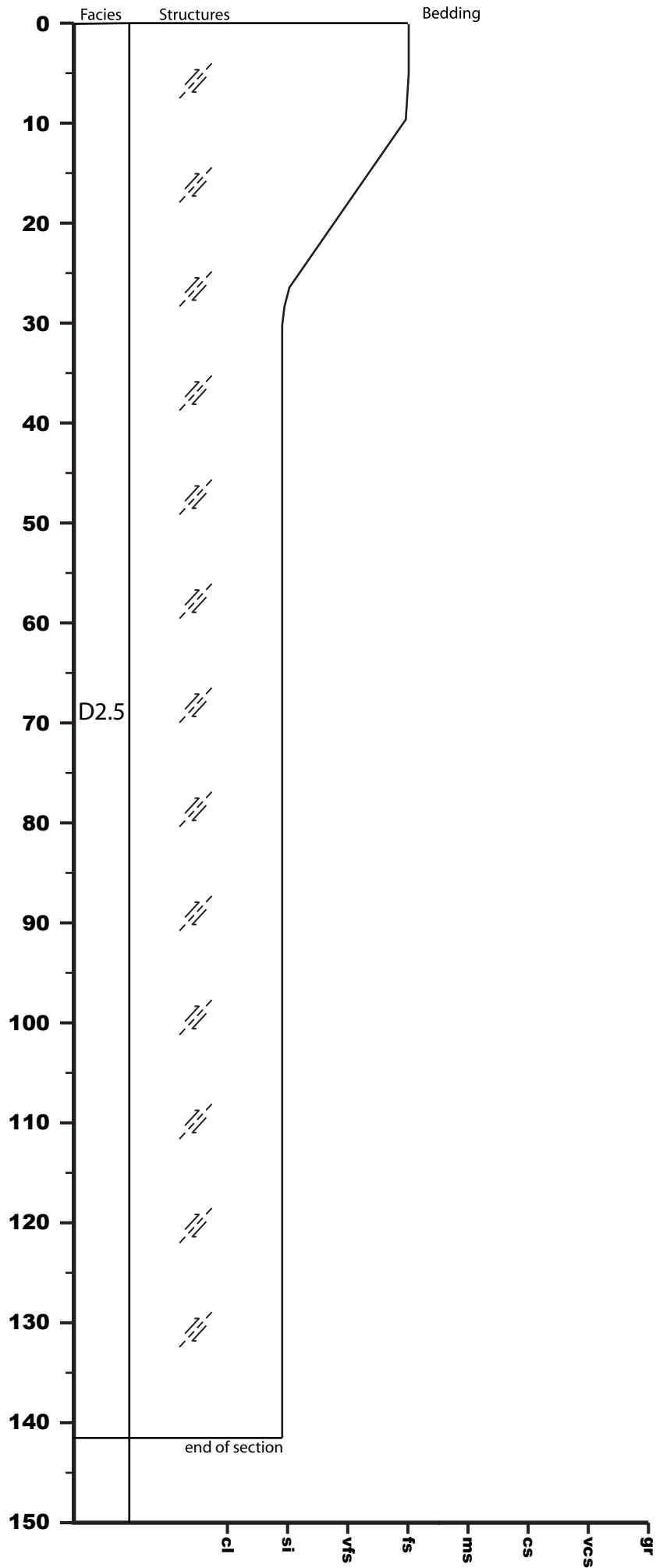



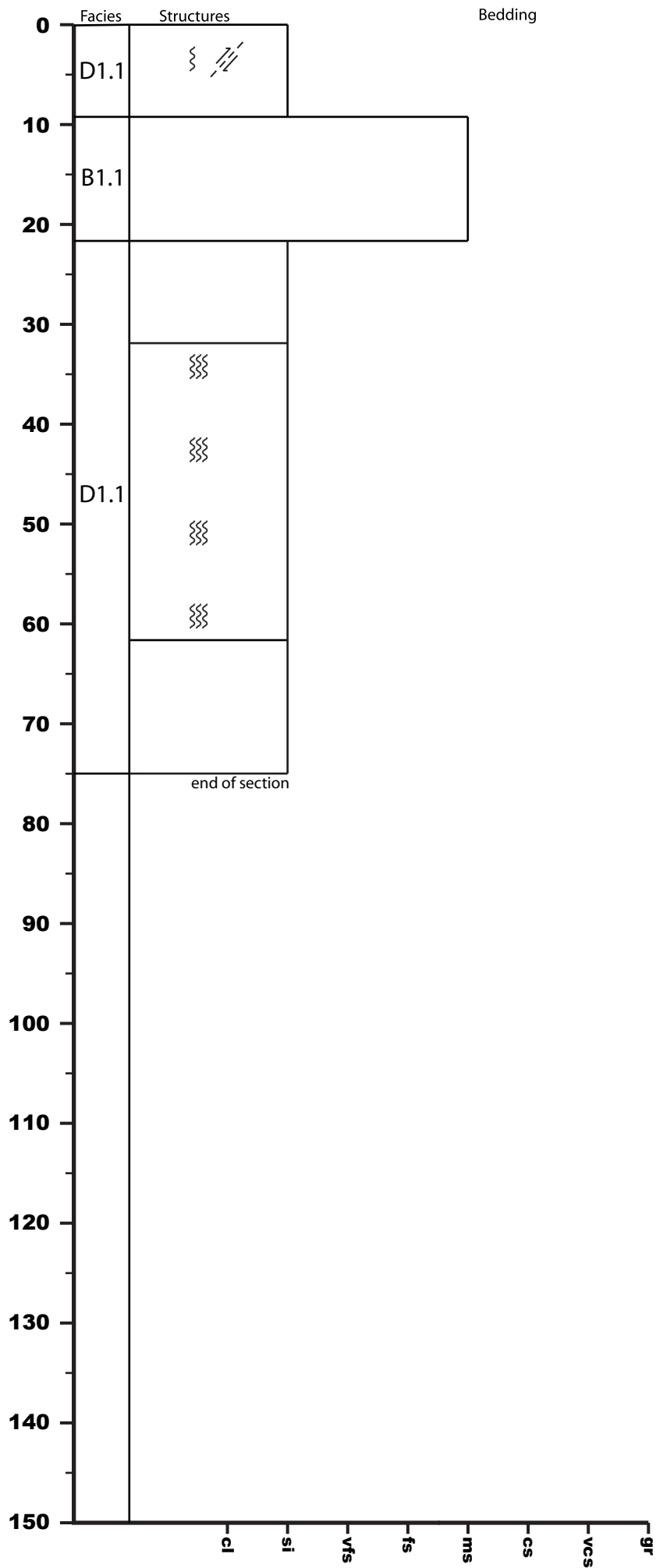

U1438E-5R-CC

885.68 - 885.81 mbsf

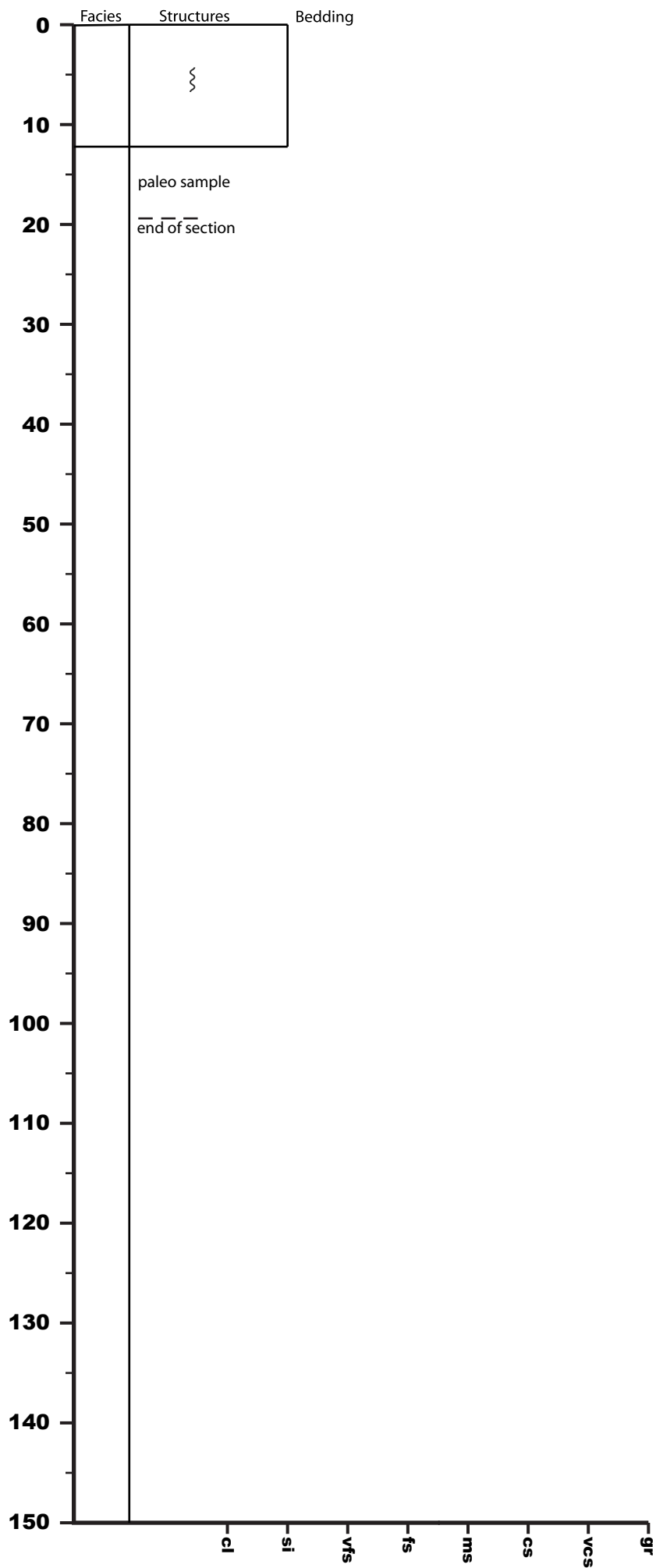

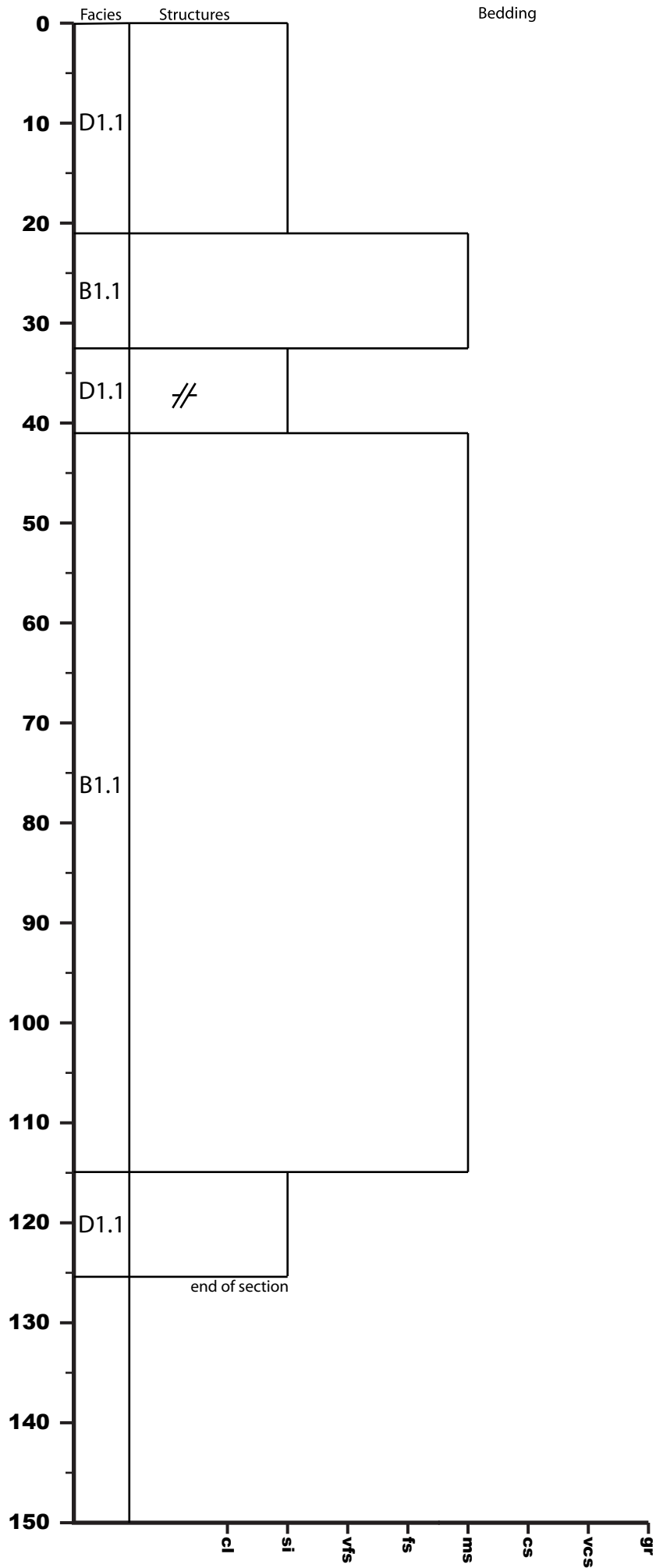

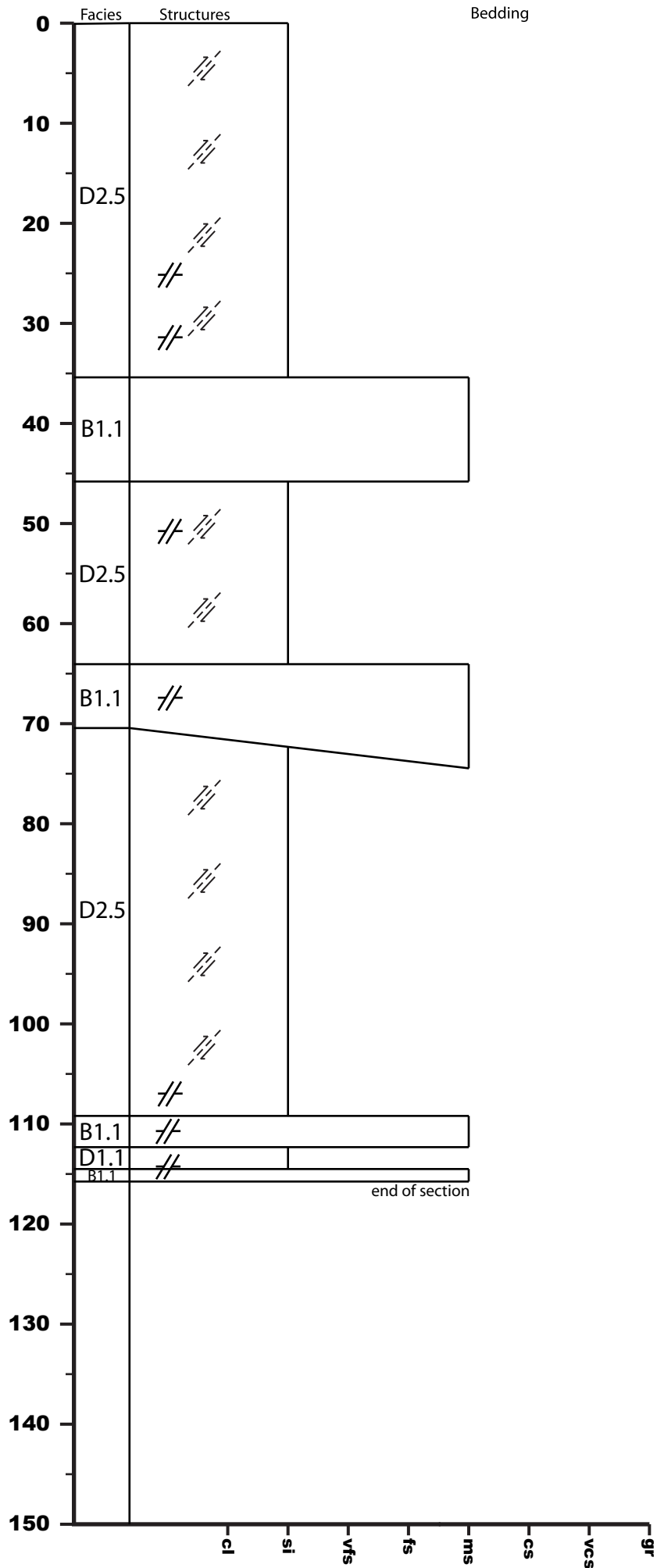

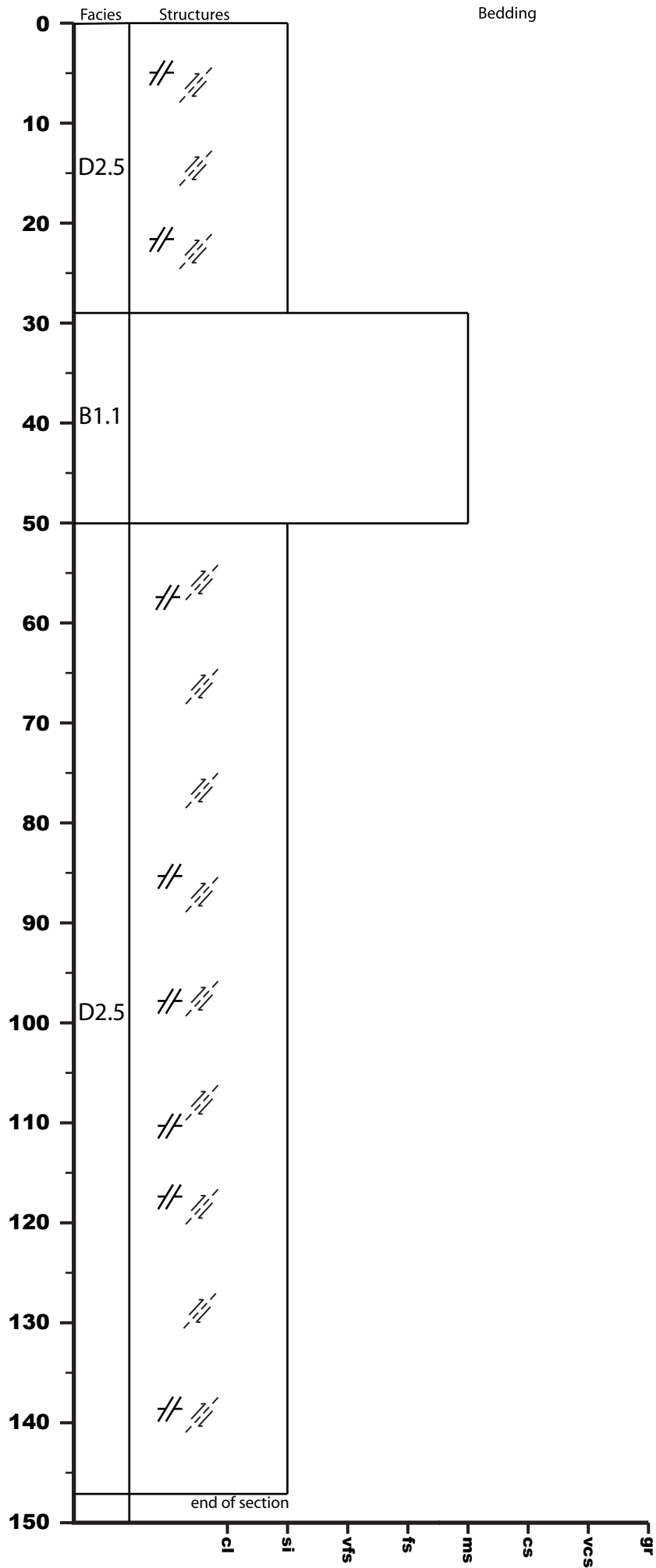

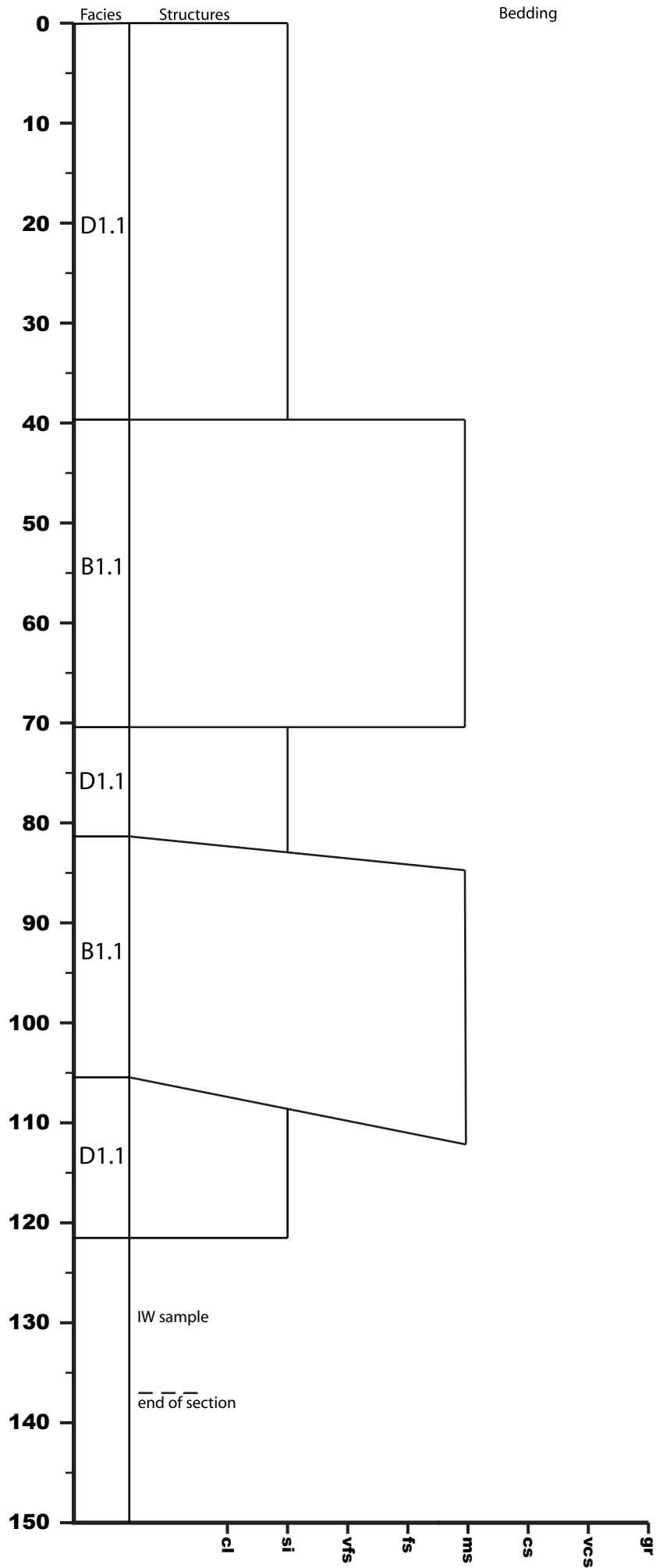

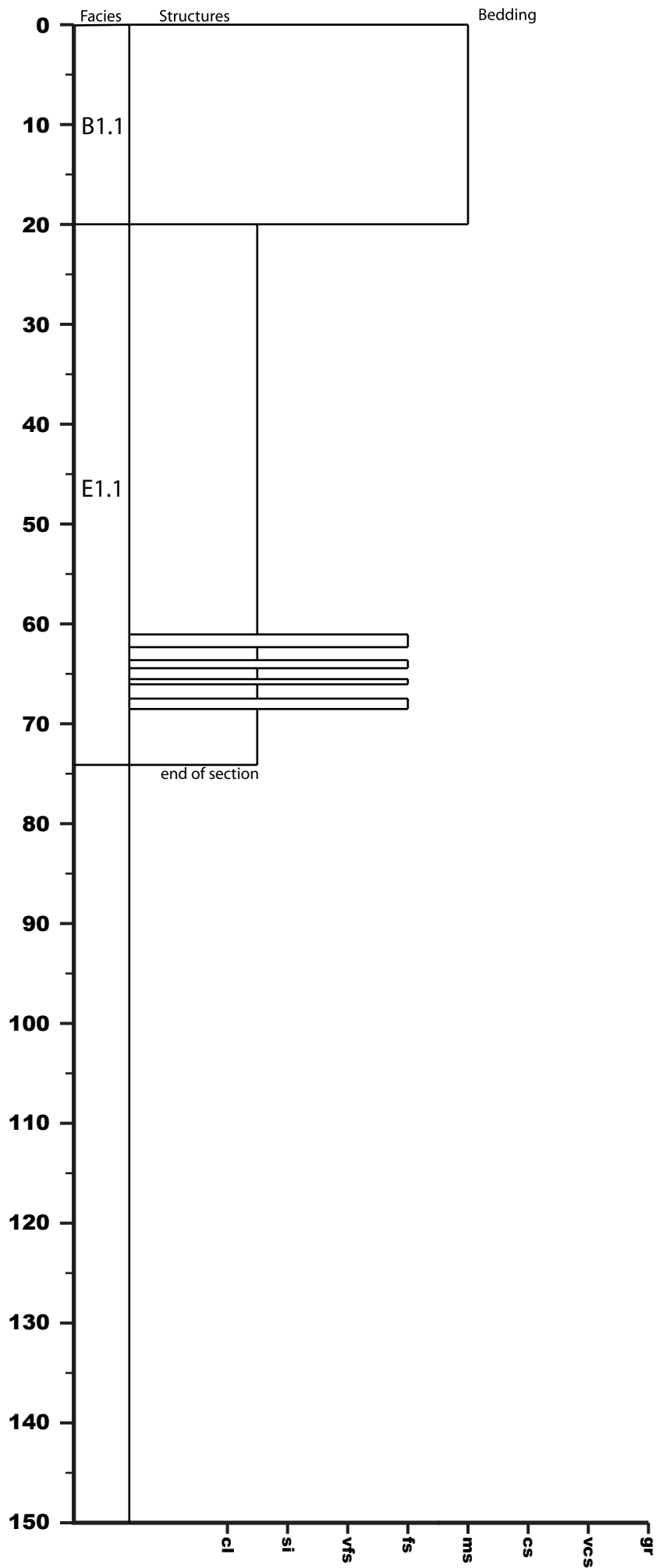

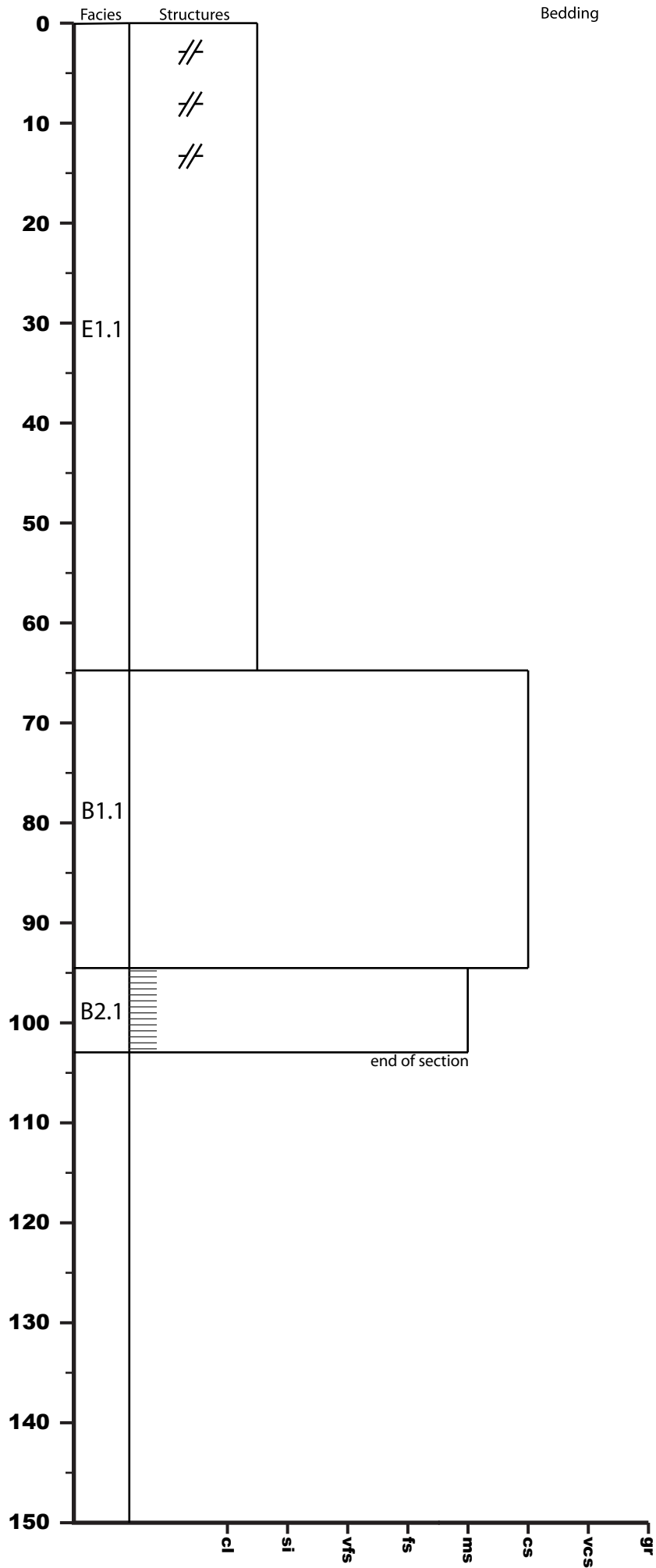



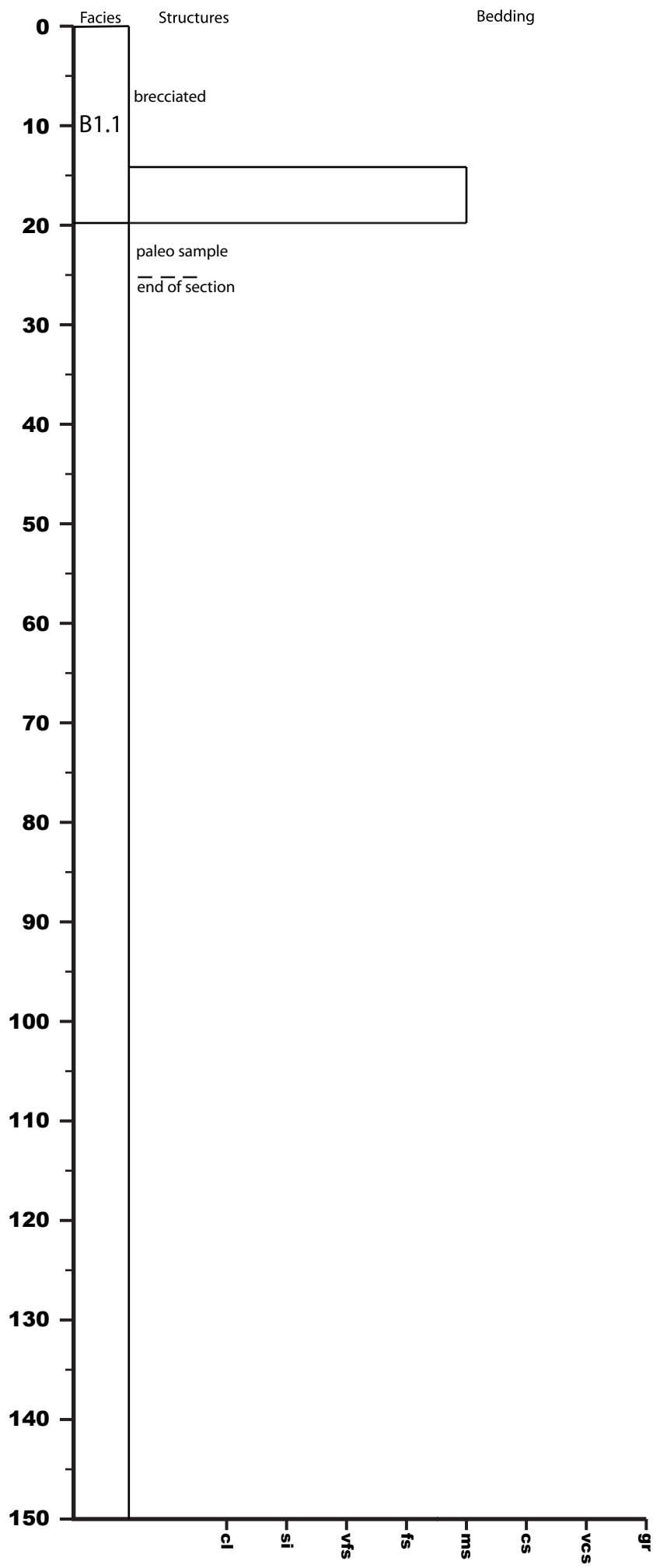

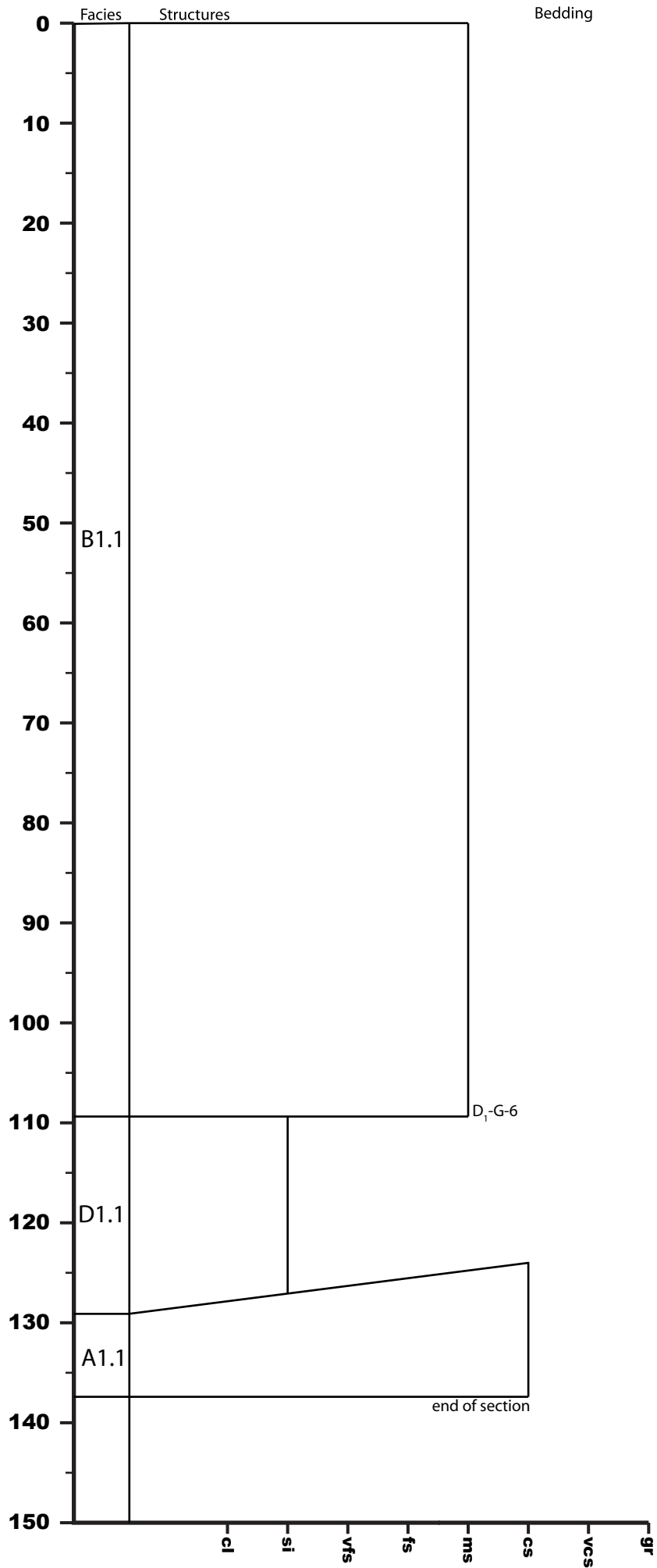

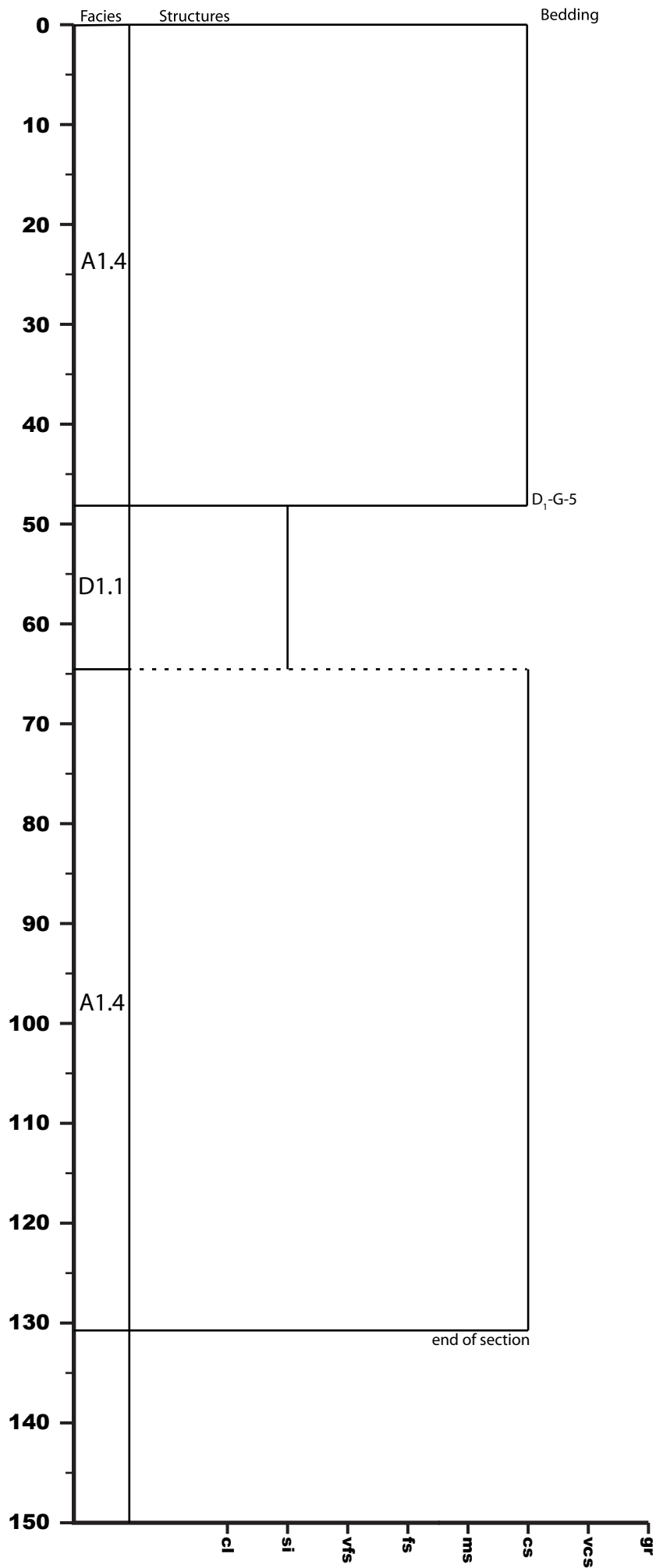

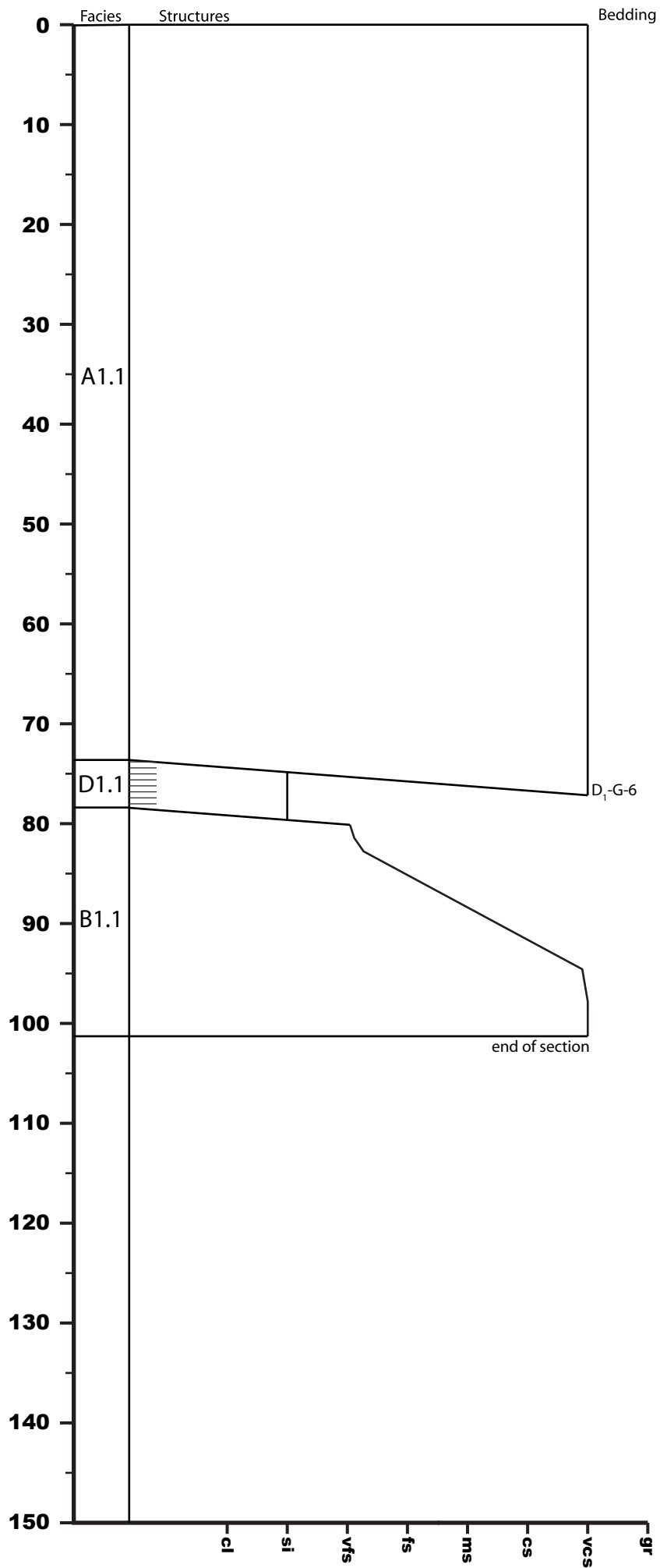

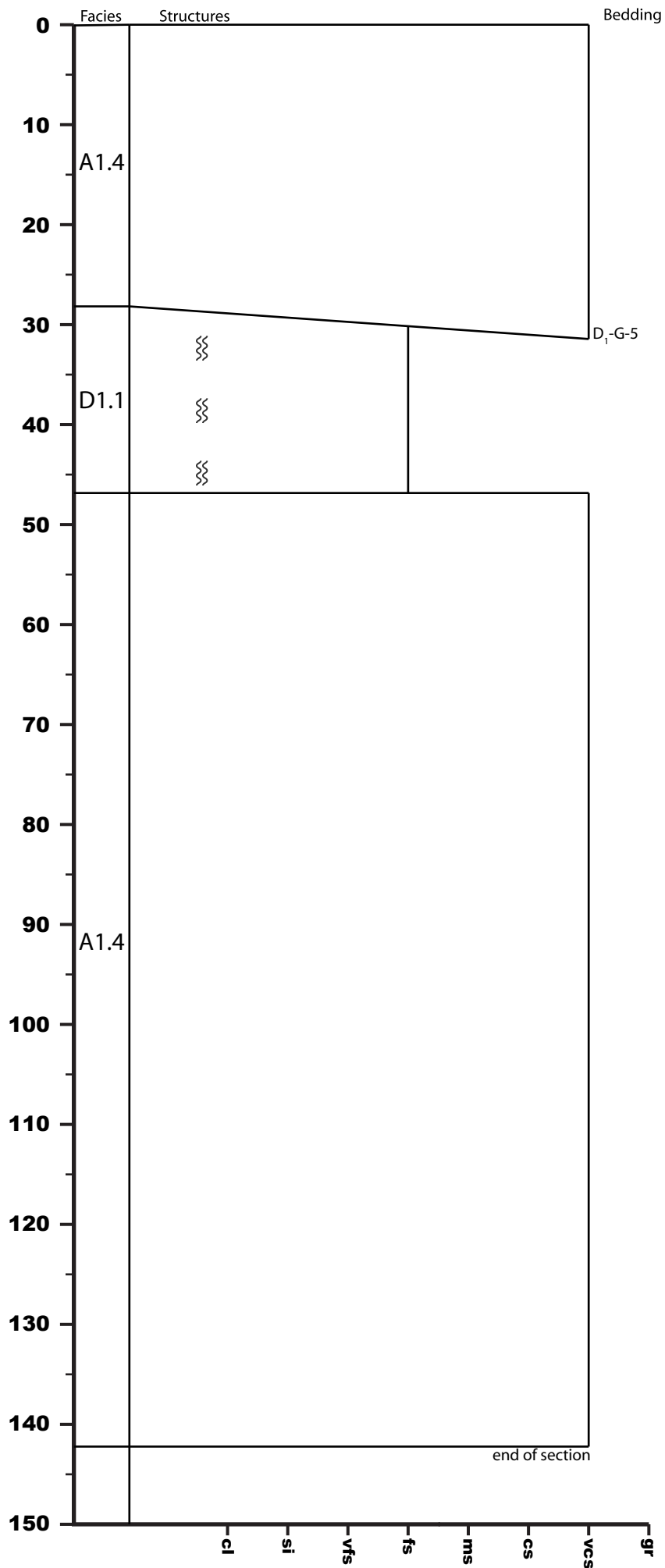

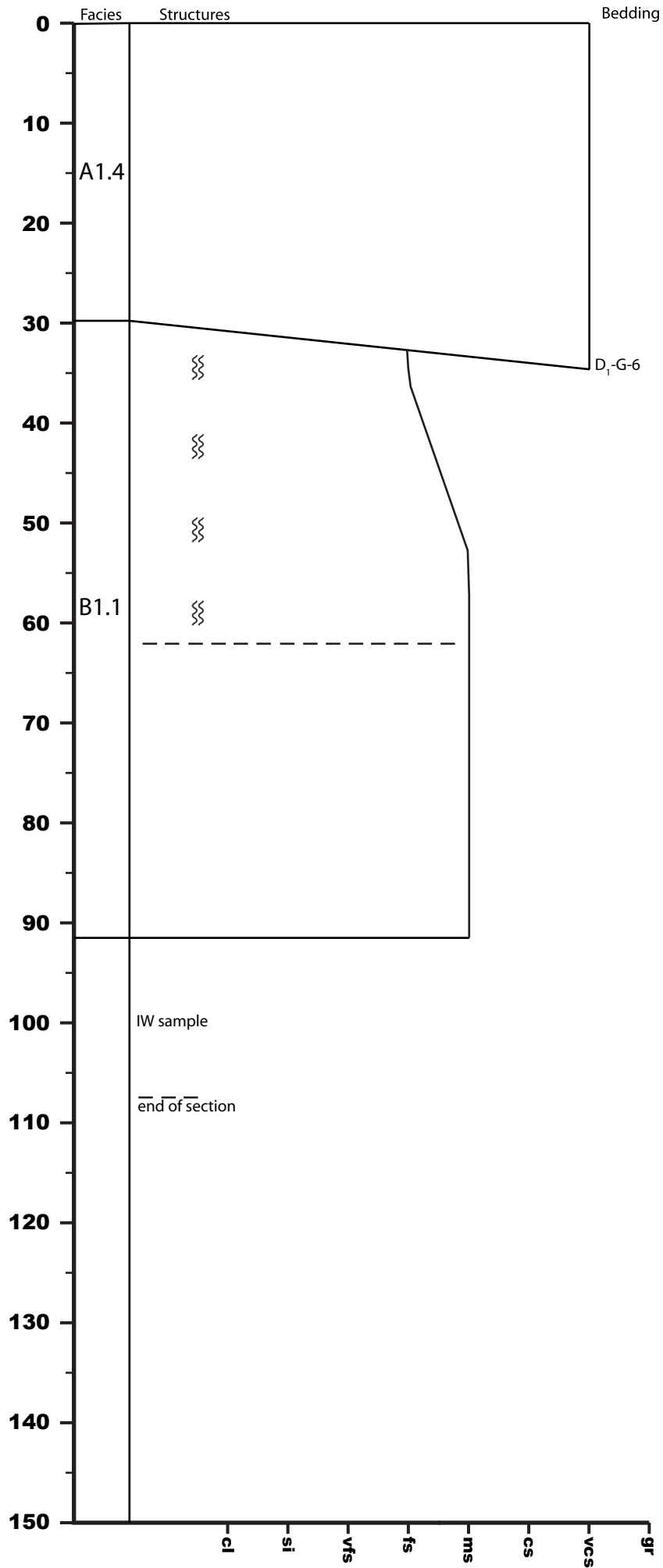

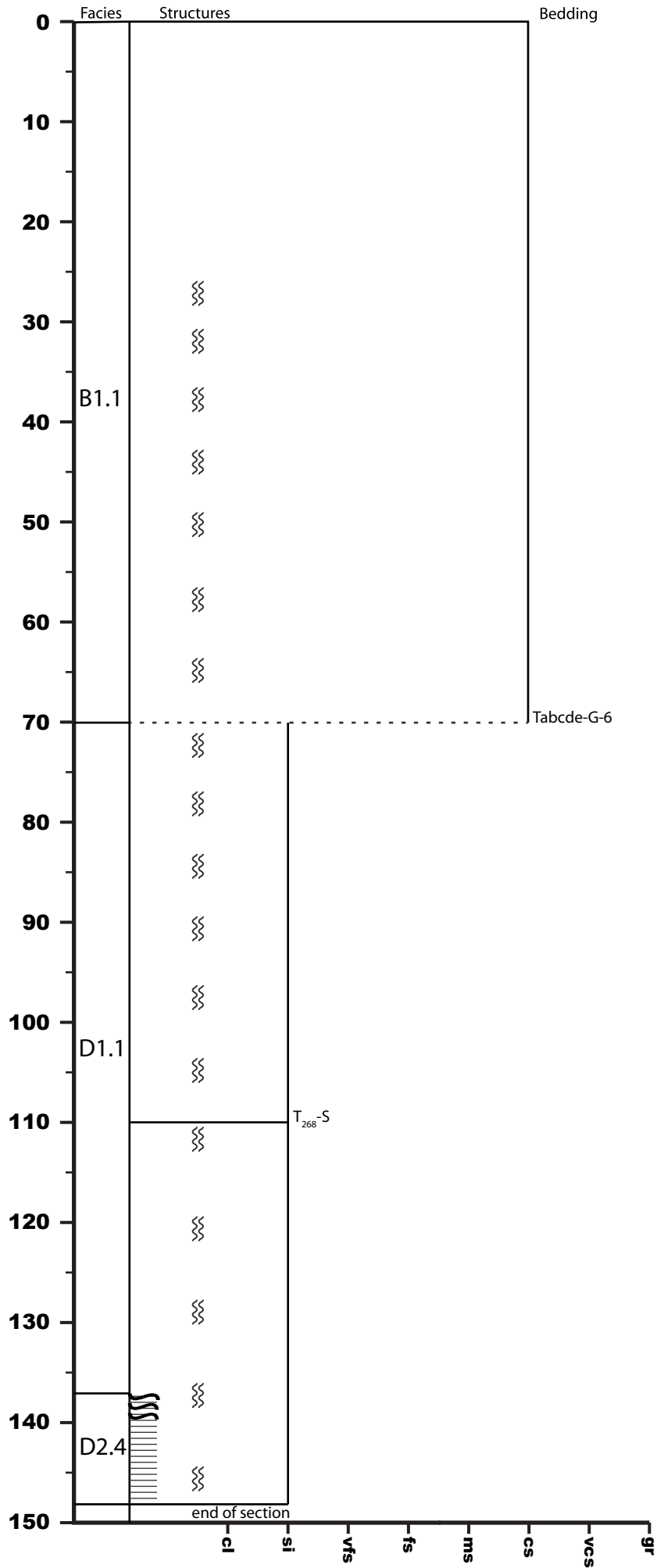

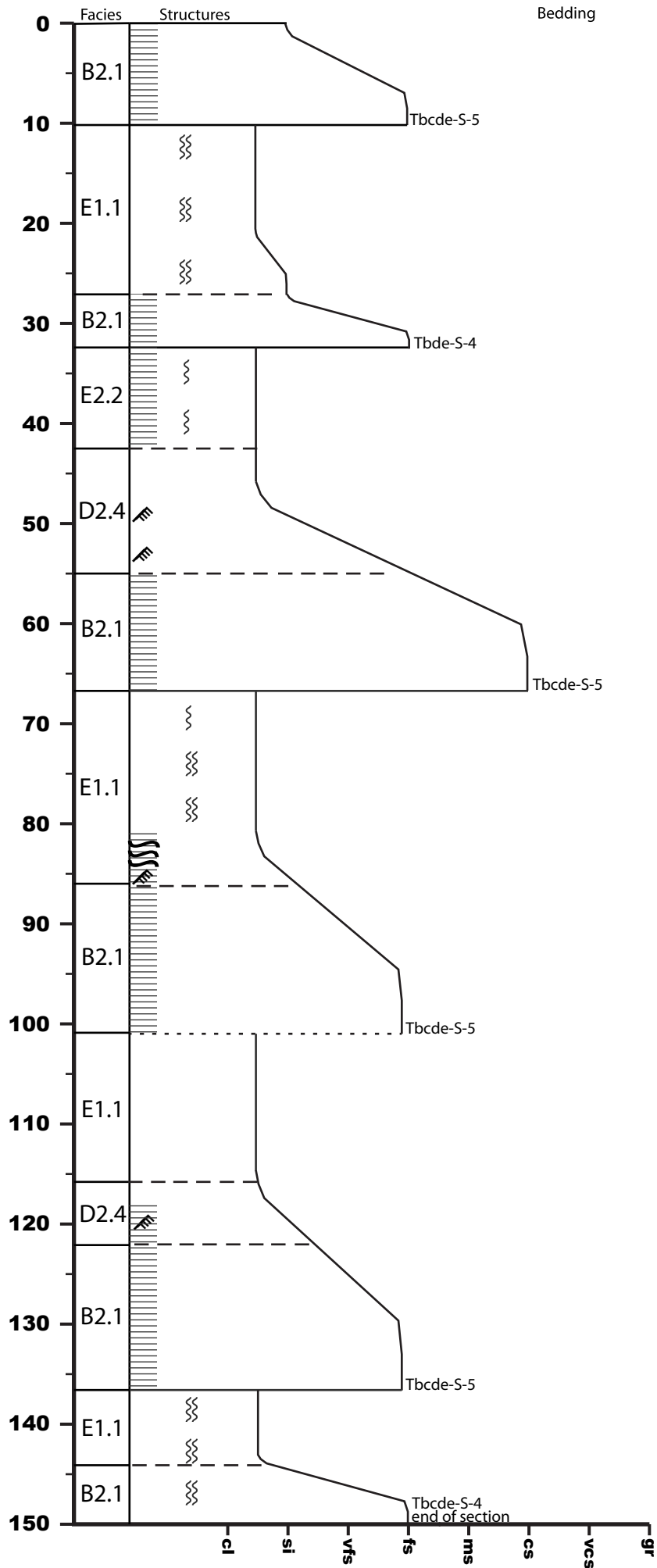



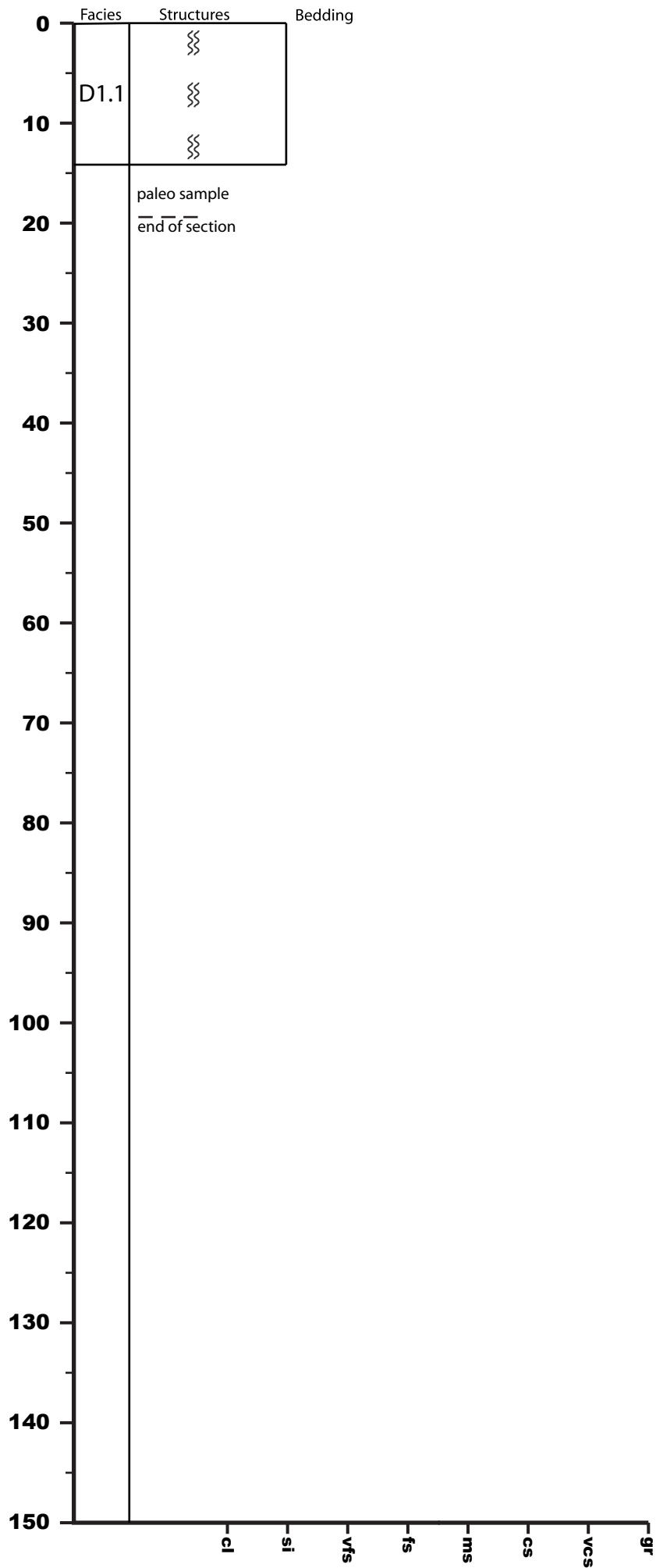

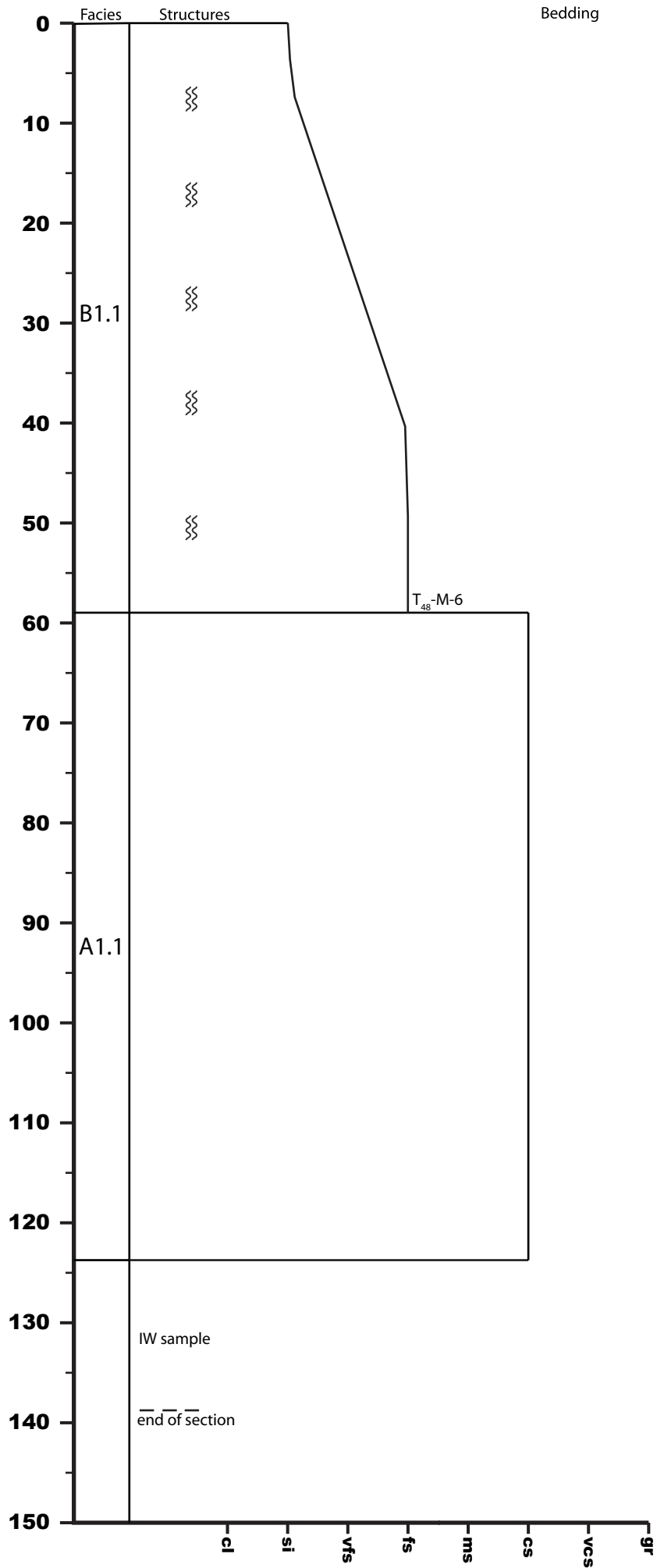

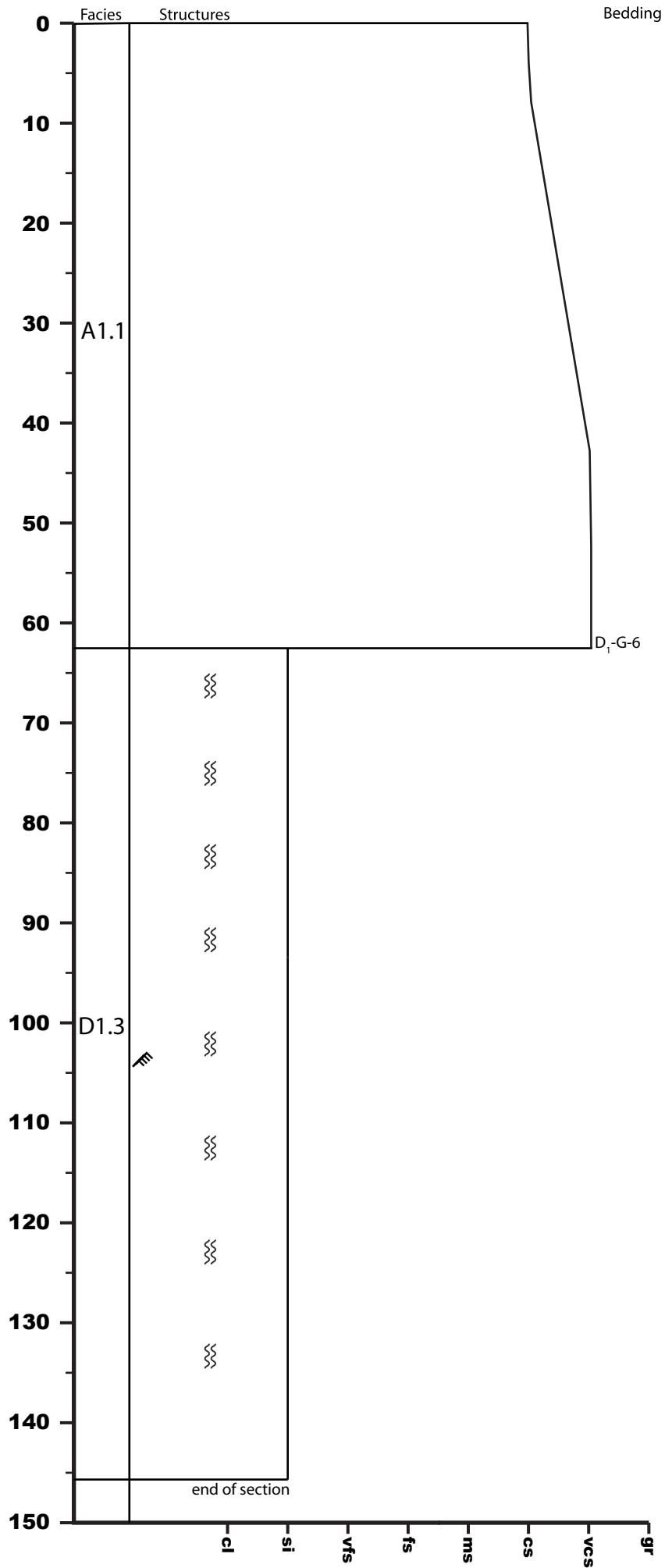

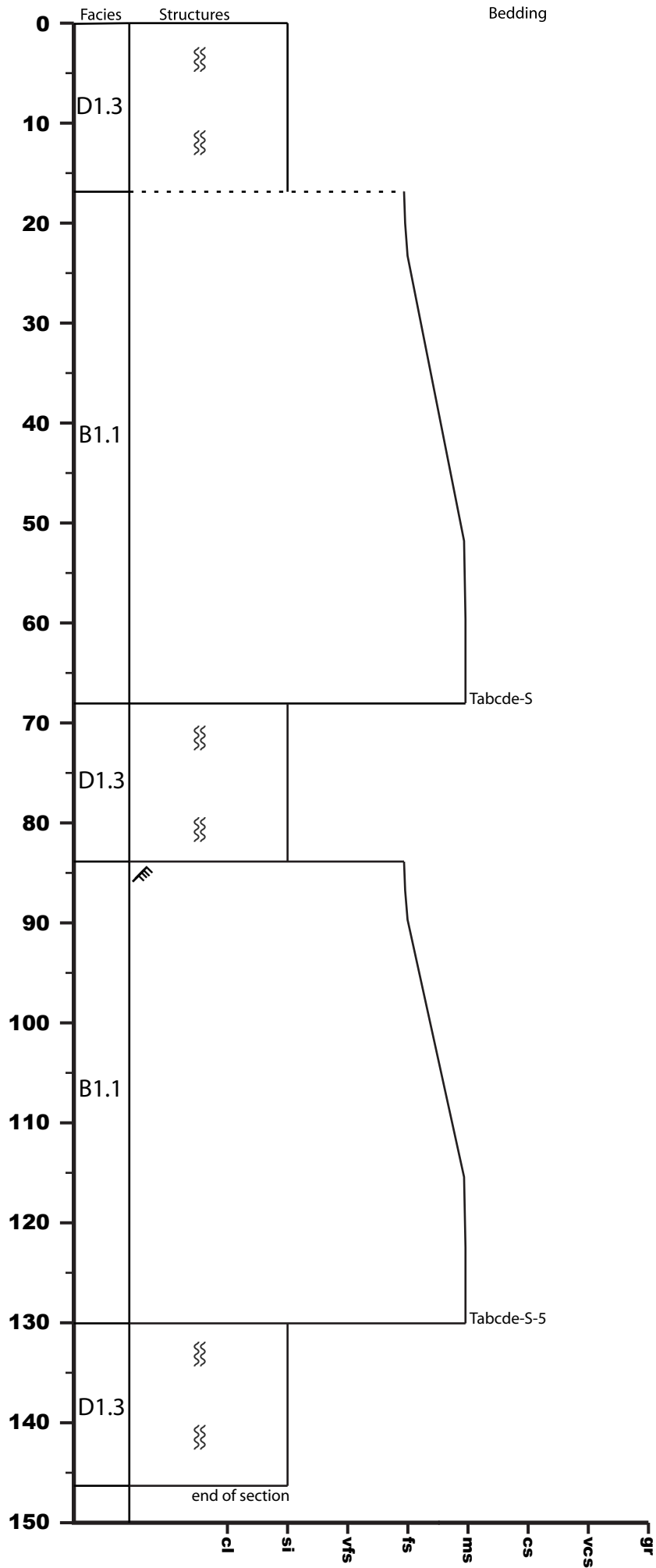

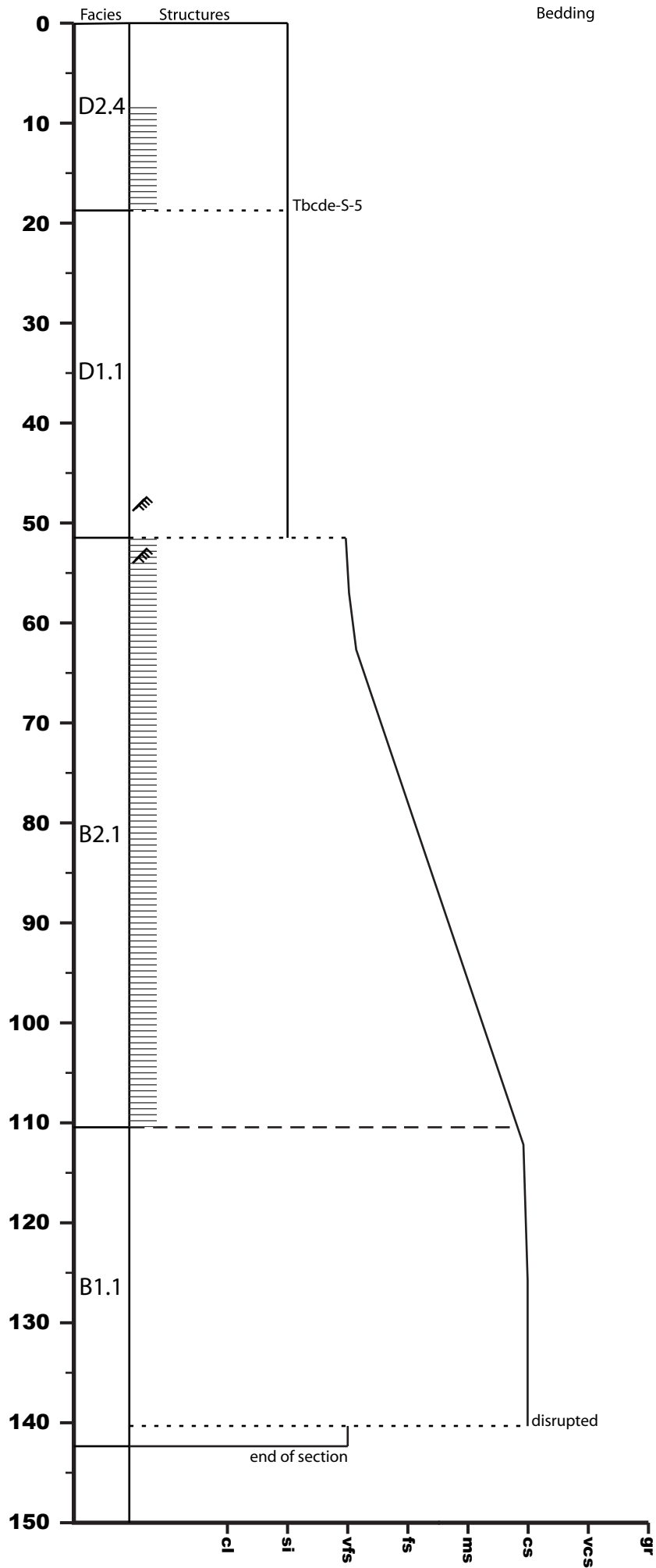

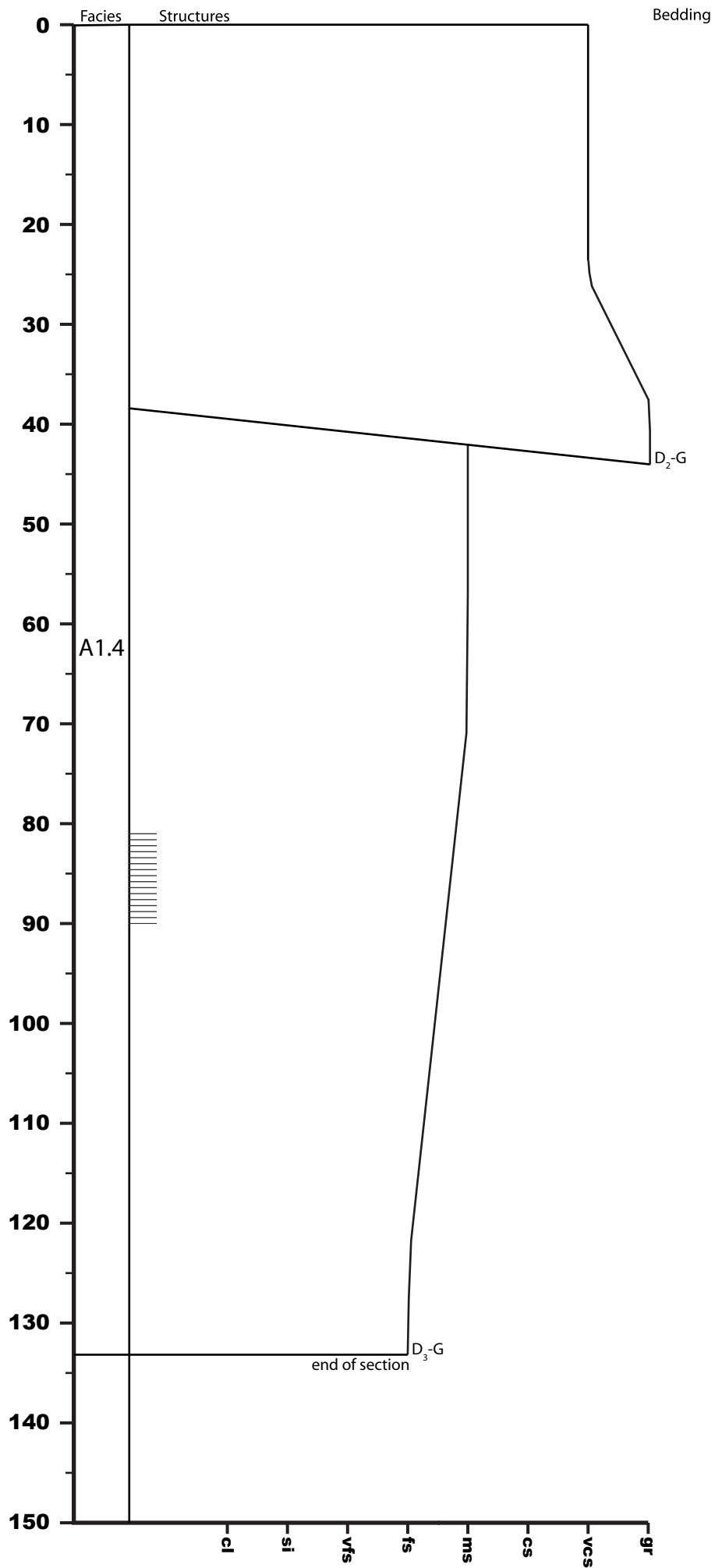

U1438E-8R-CC

913.06 - 913.28 mbsf

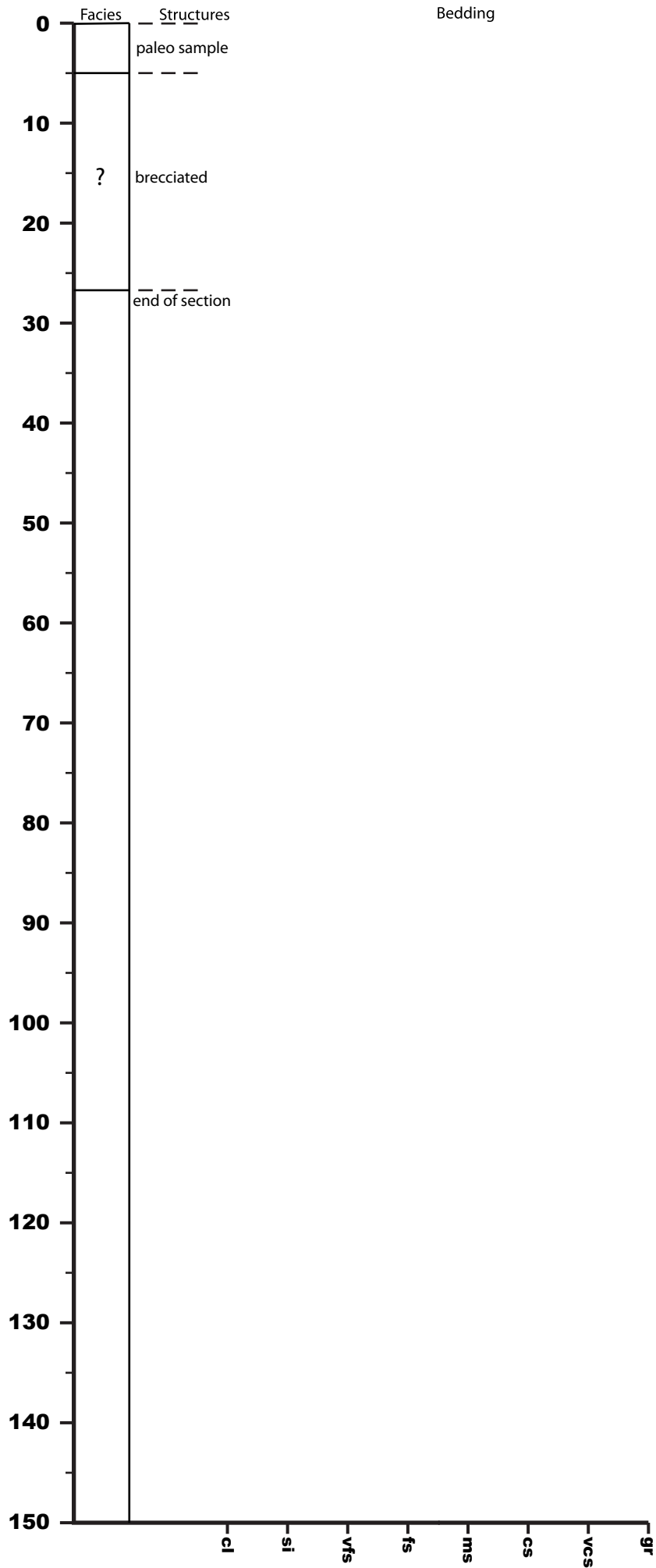

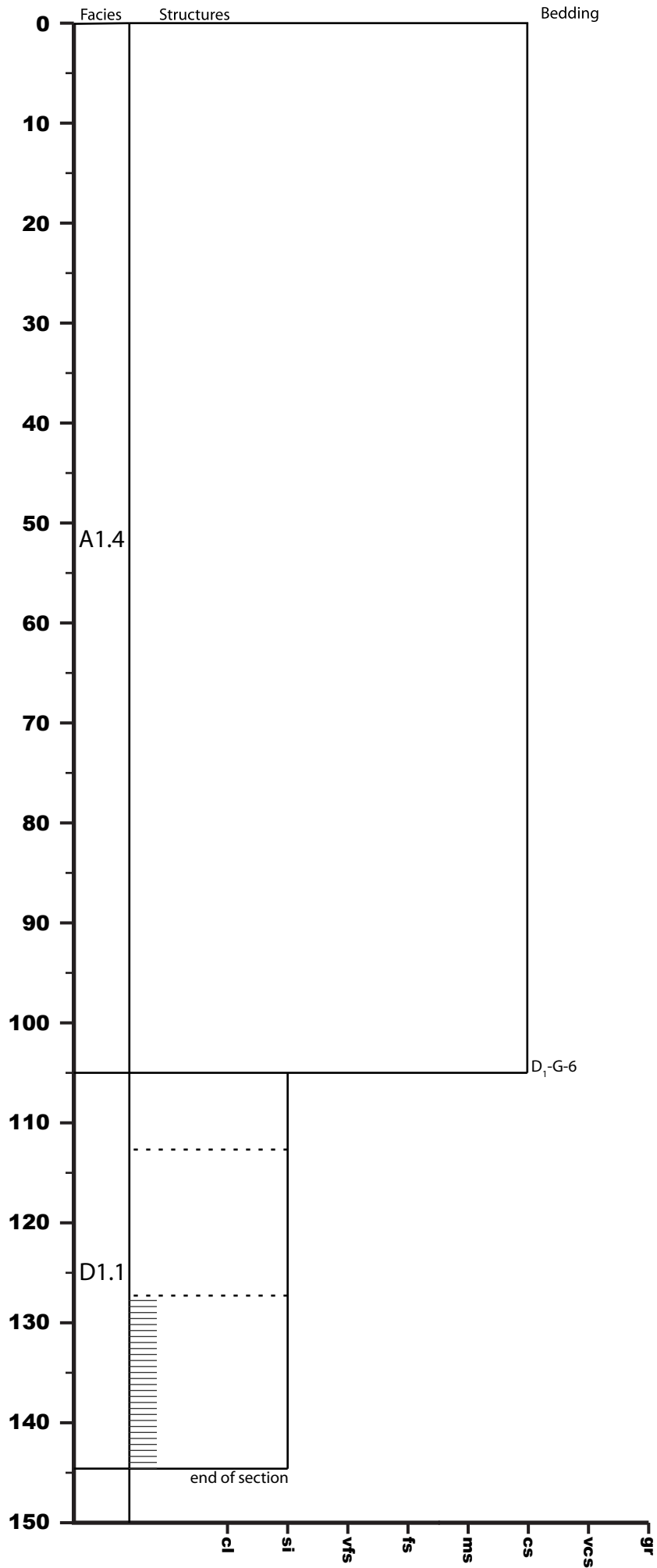



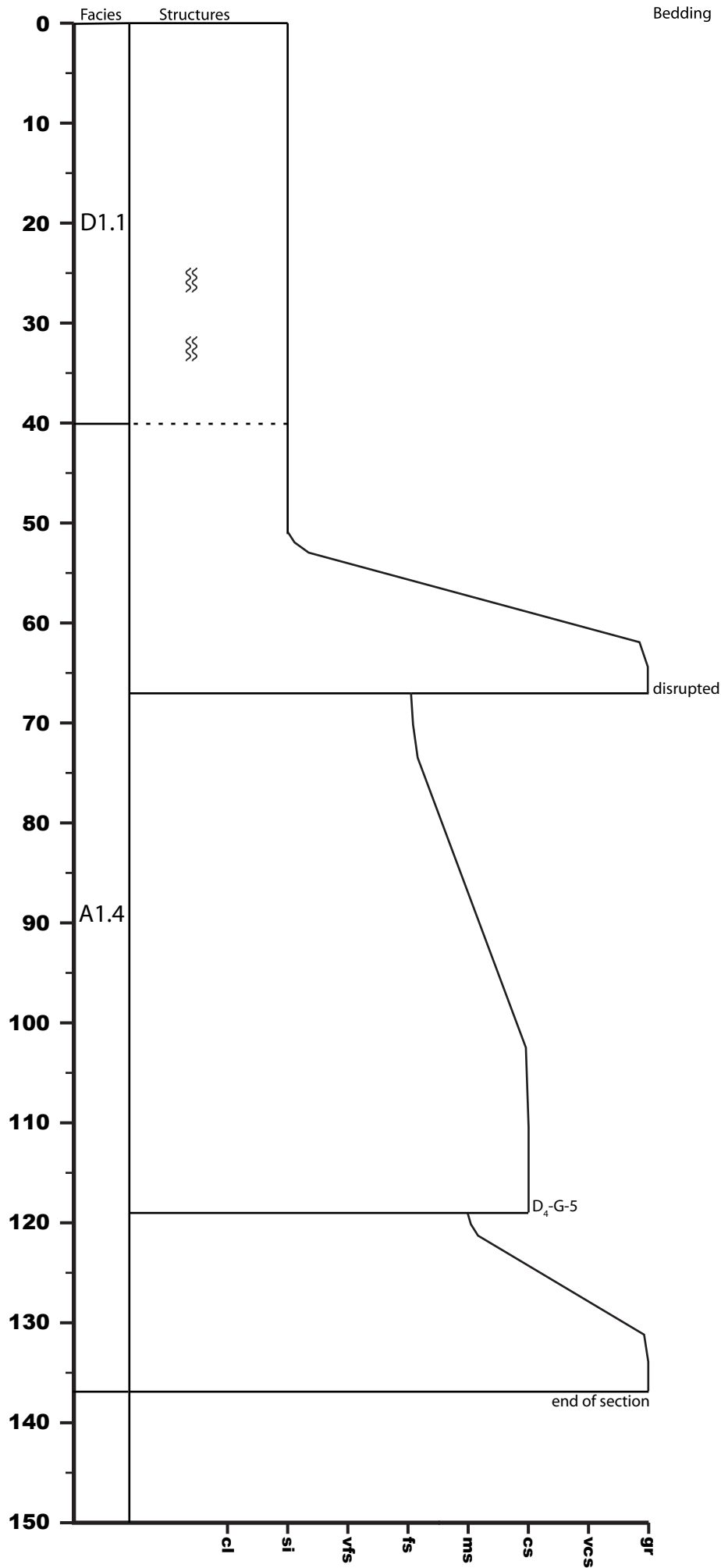

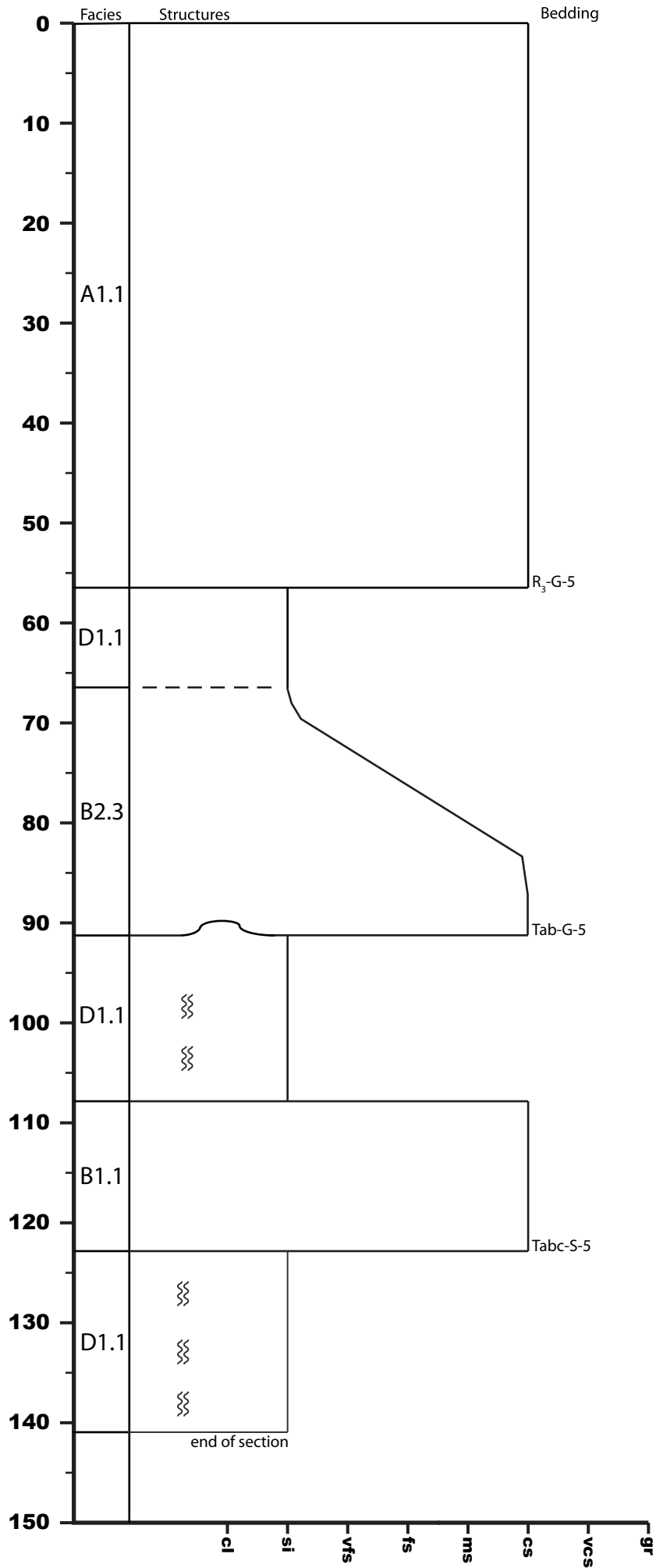

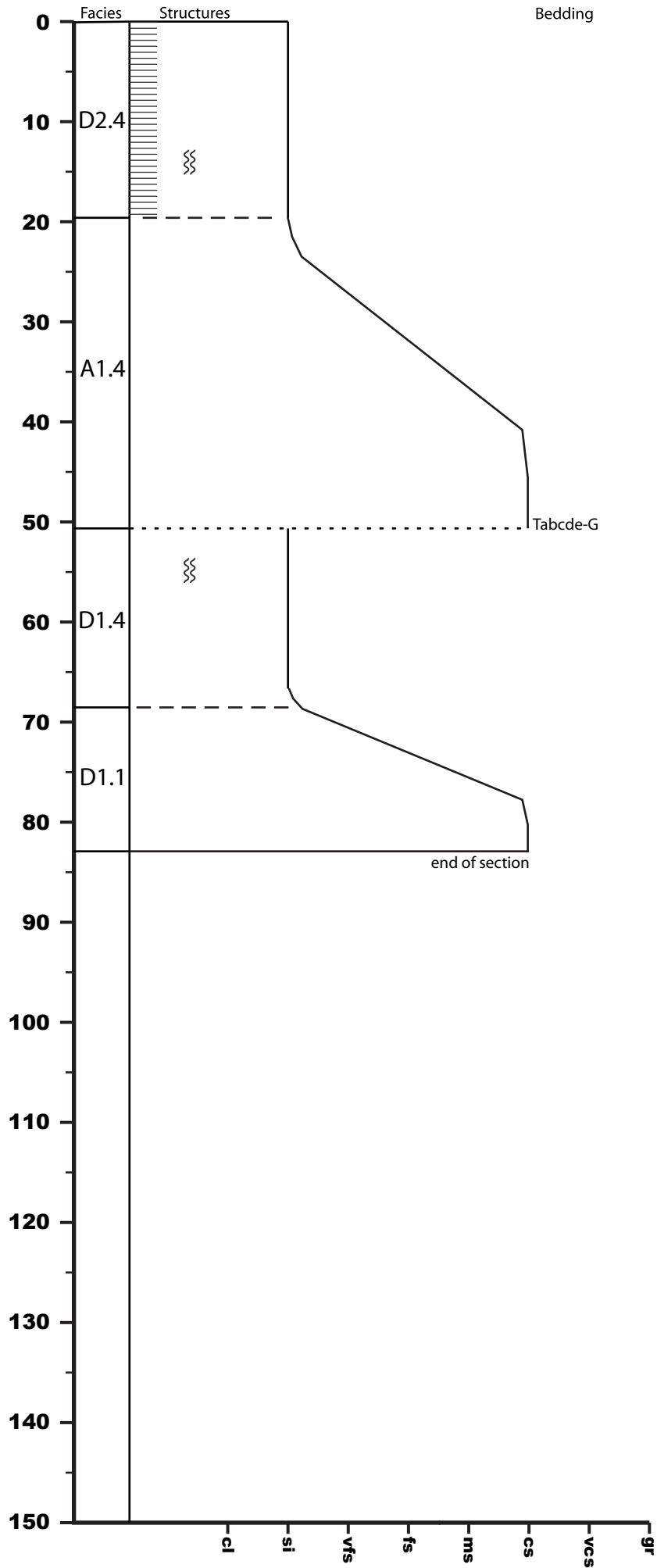

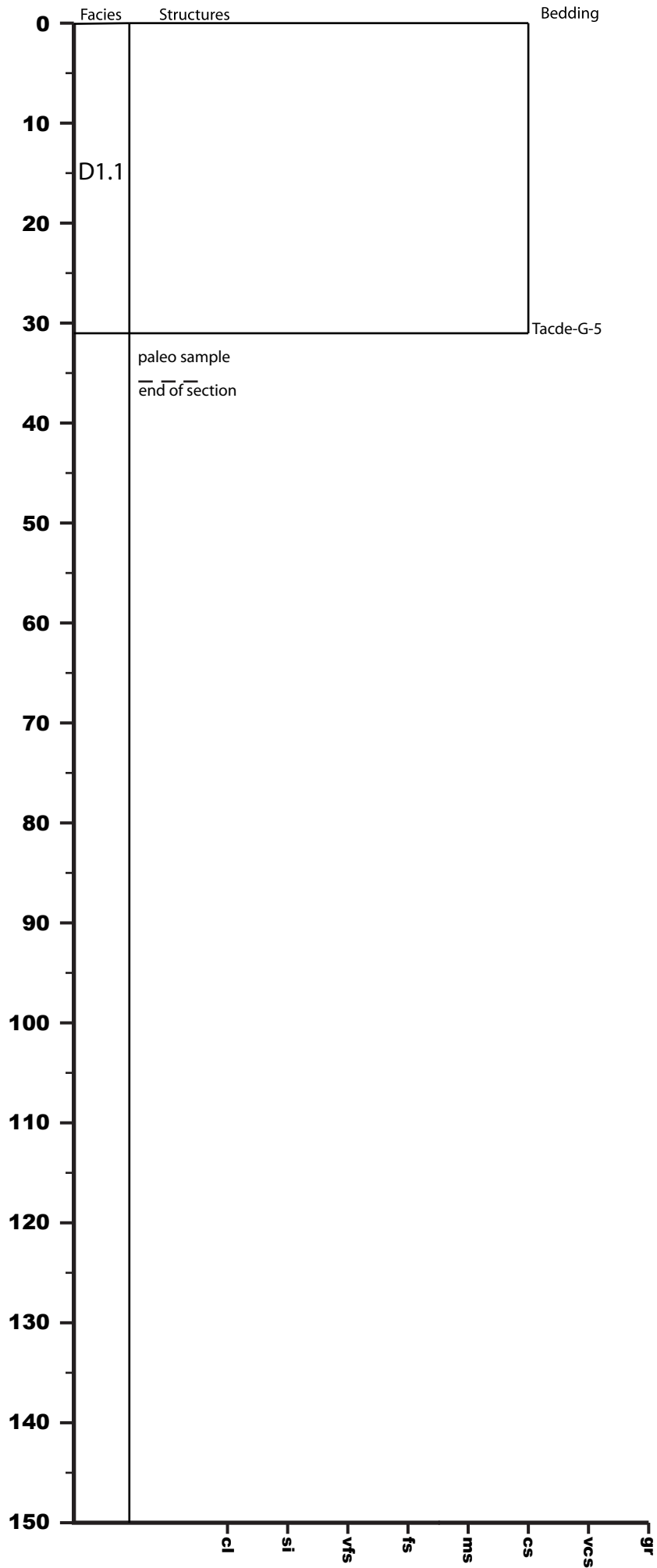

U1438E-10R-1

925.3 - 926.8 mbsf

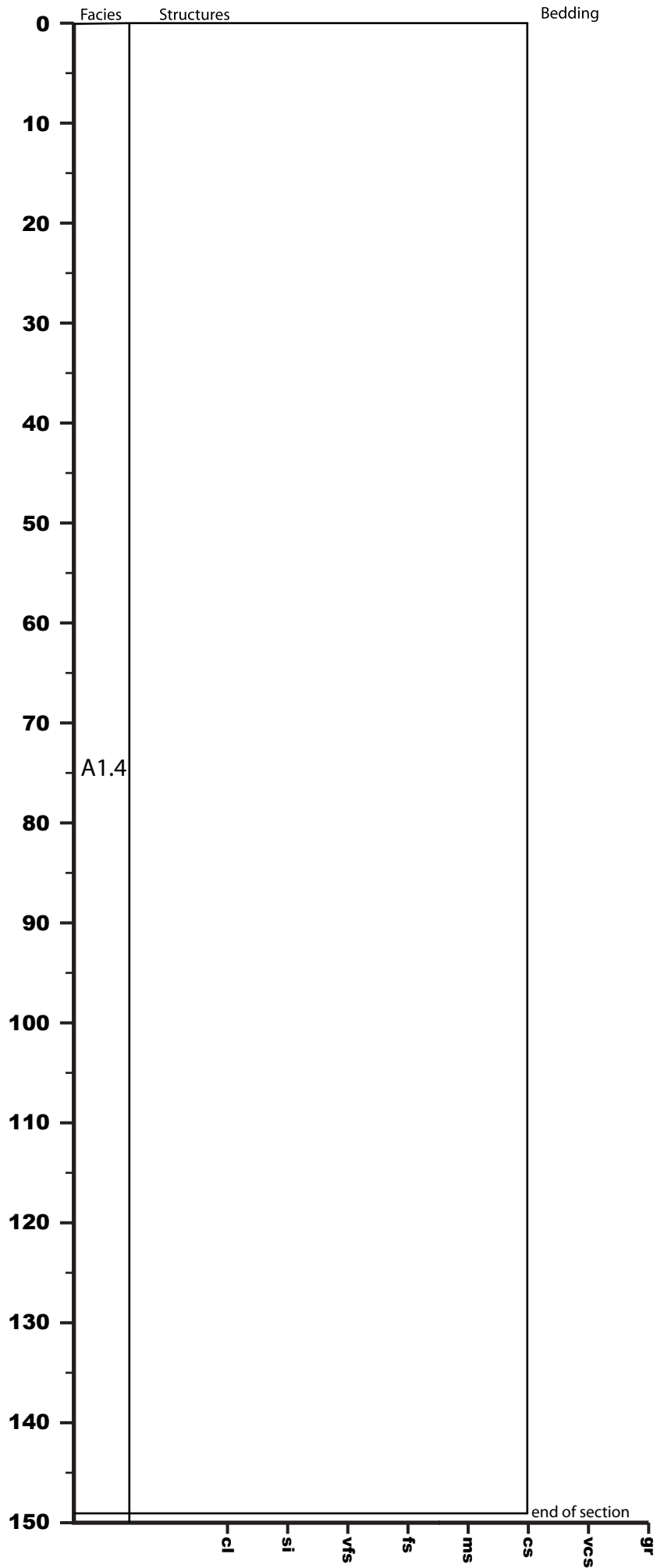

U1438E-10R-2

926.8 - 928.3 mbsf

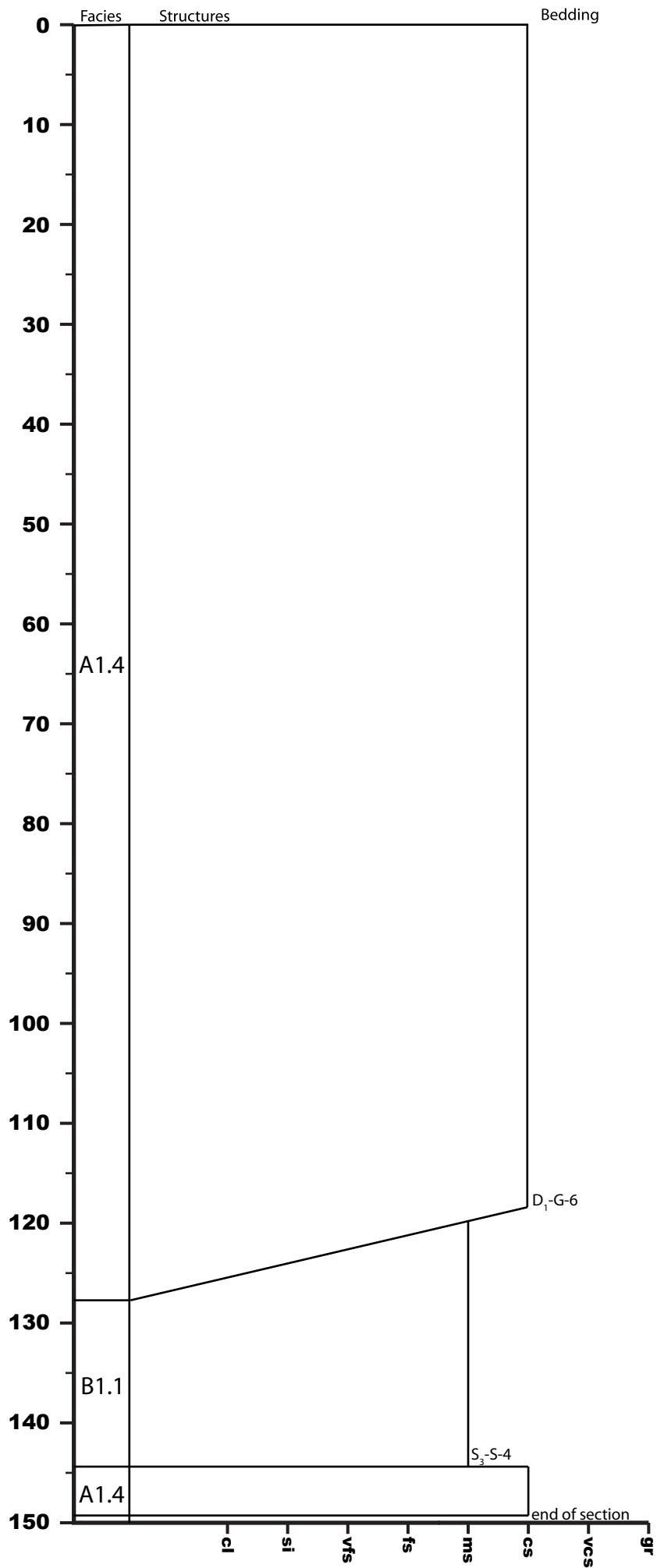

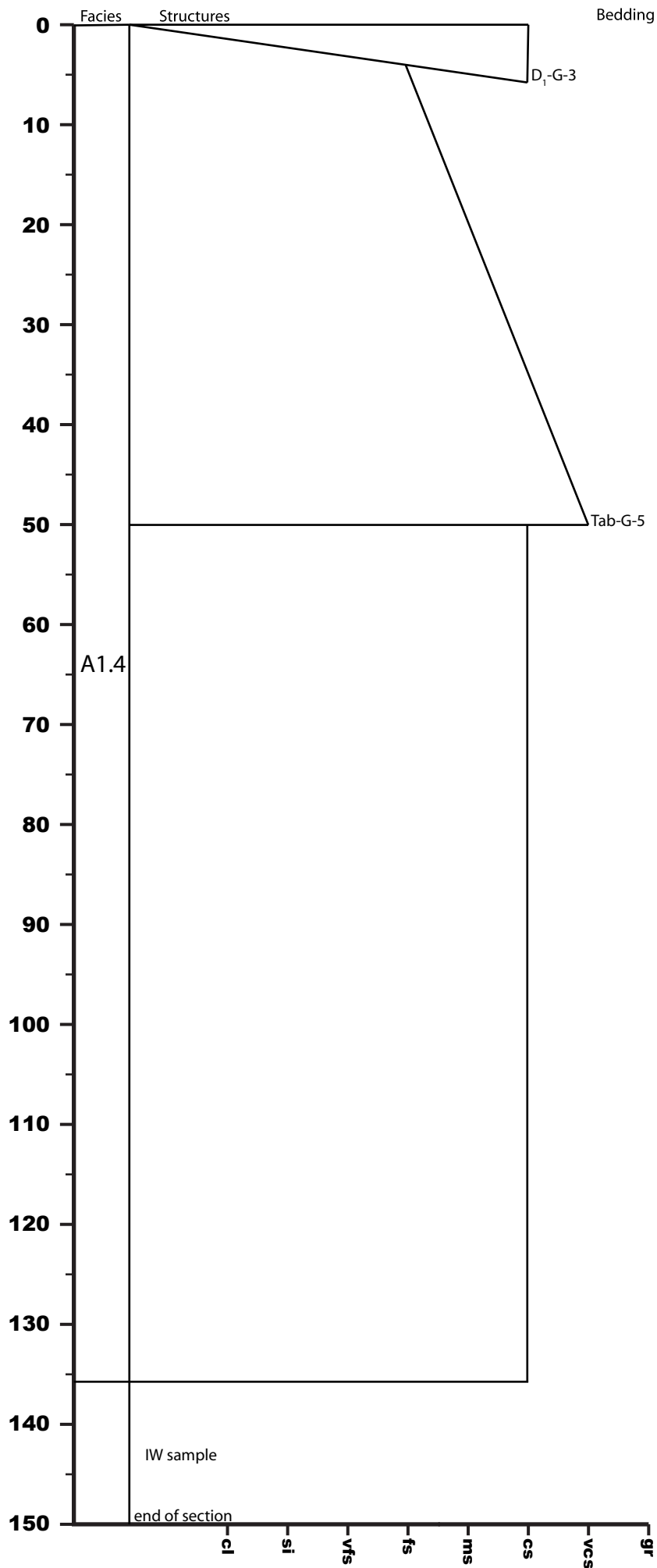

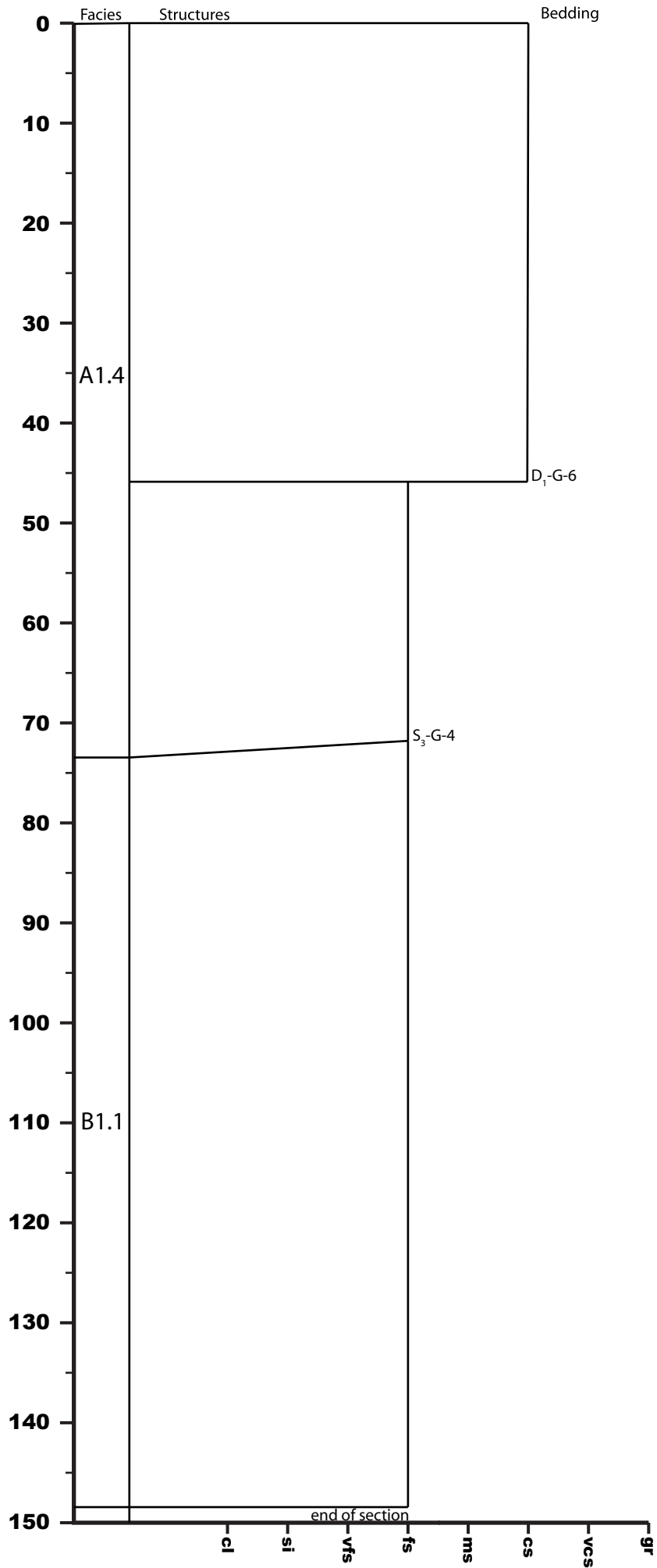



U1438E-10R-5

931.3 - 932.8 mbsf

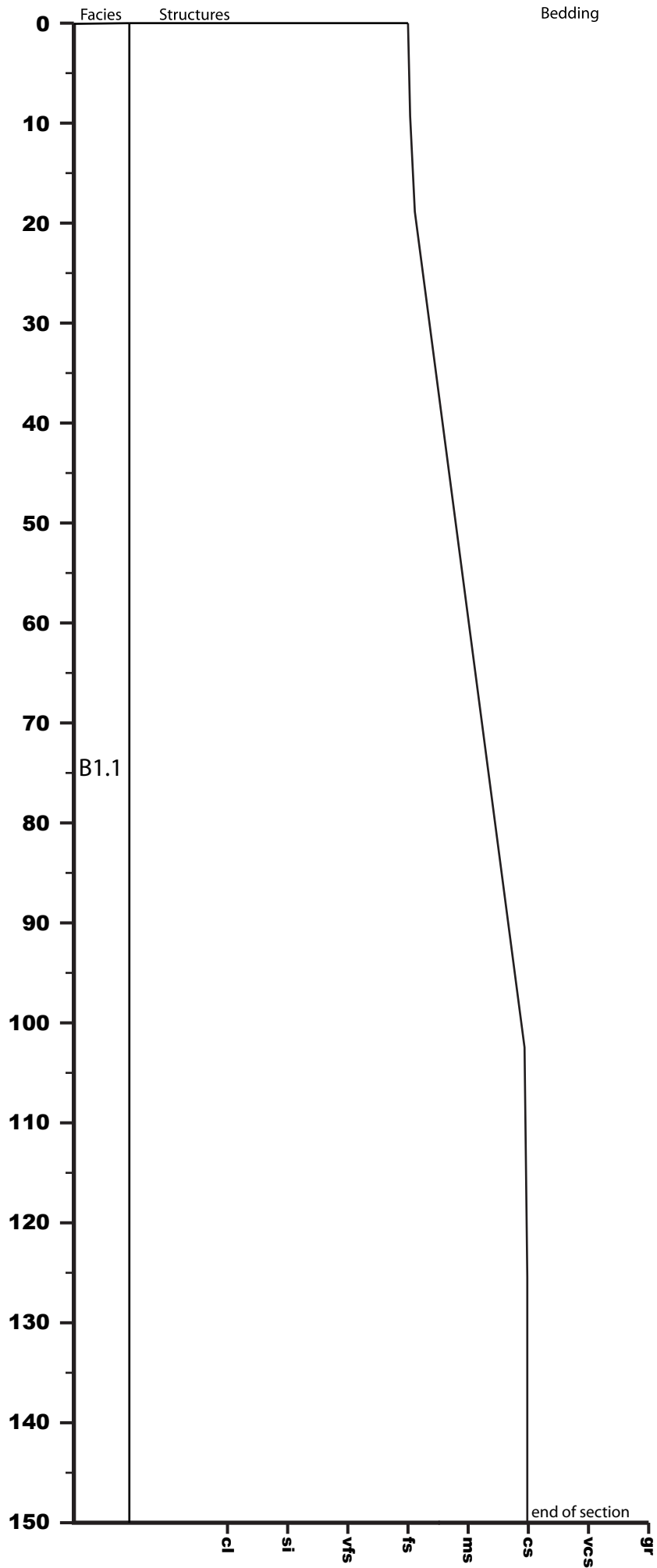

U1438E-10R-6

932.8 - 934.3 mbsf

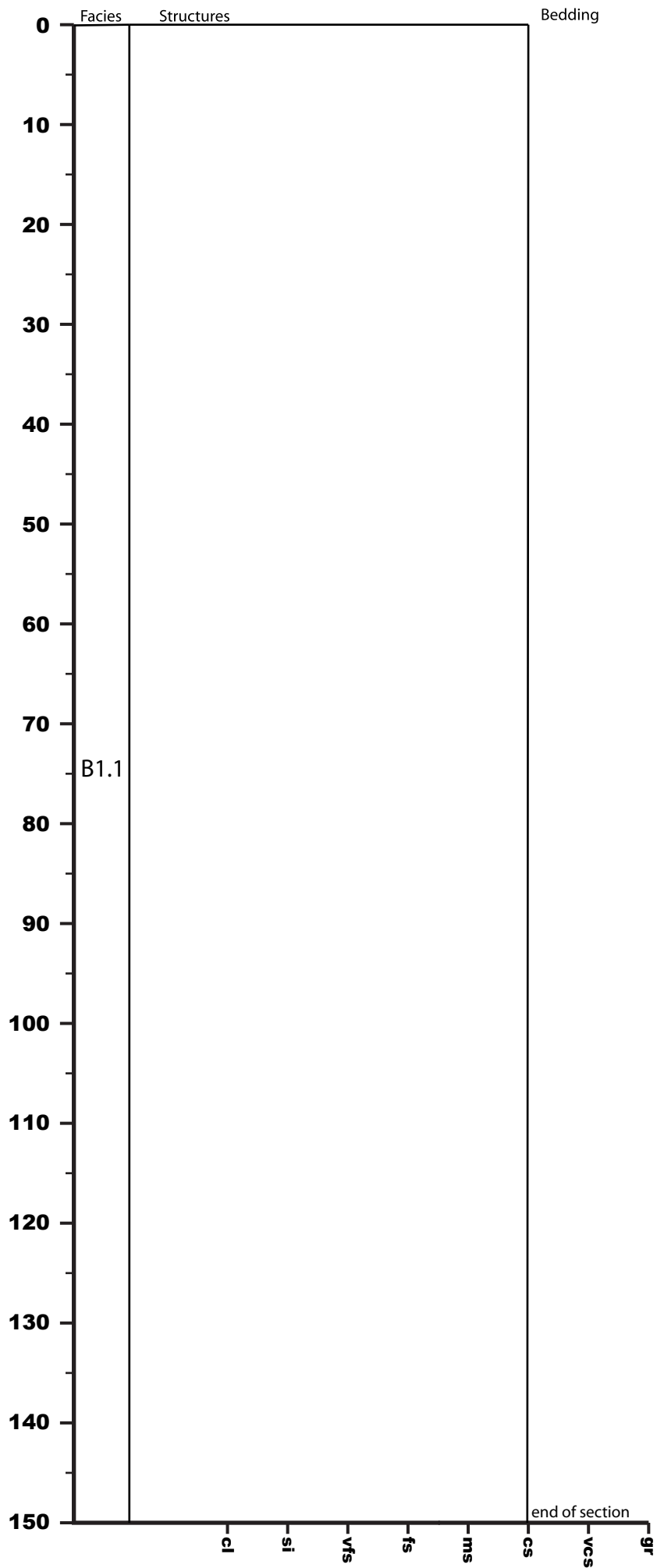

U1438E-10R-7

934.3 - 935.07 mbsf

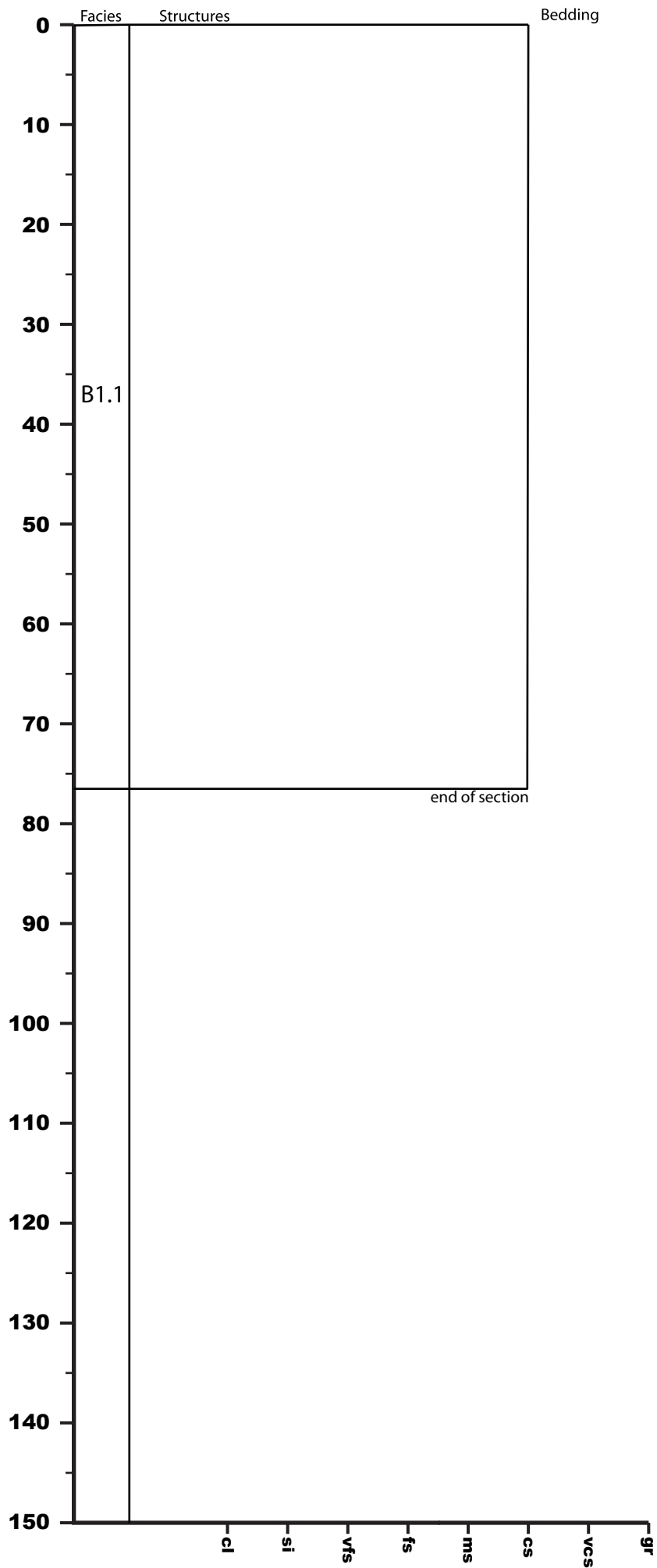

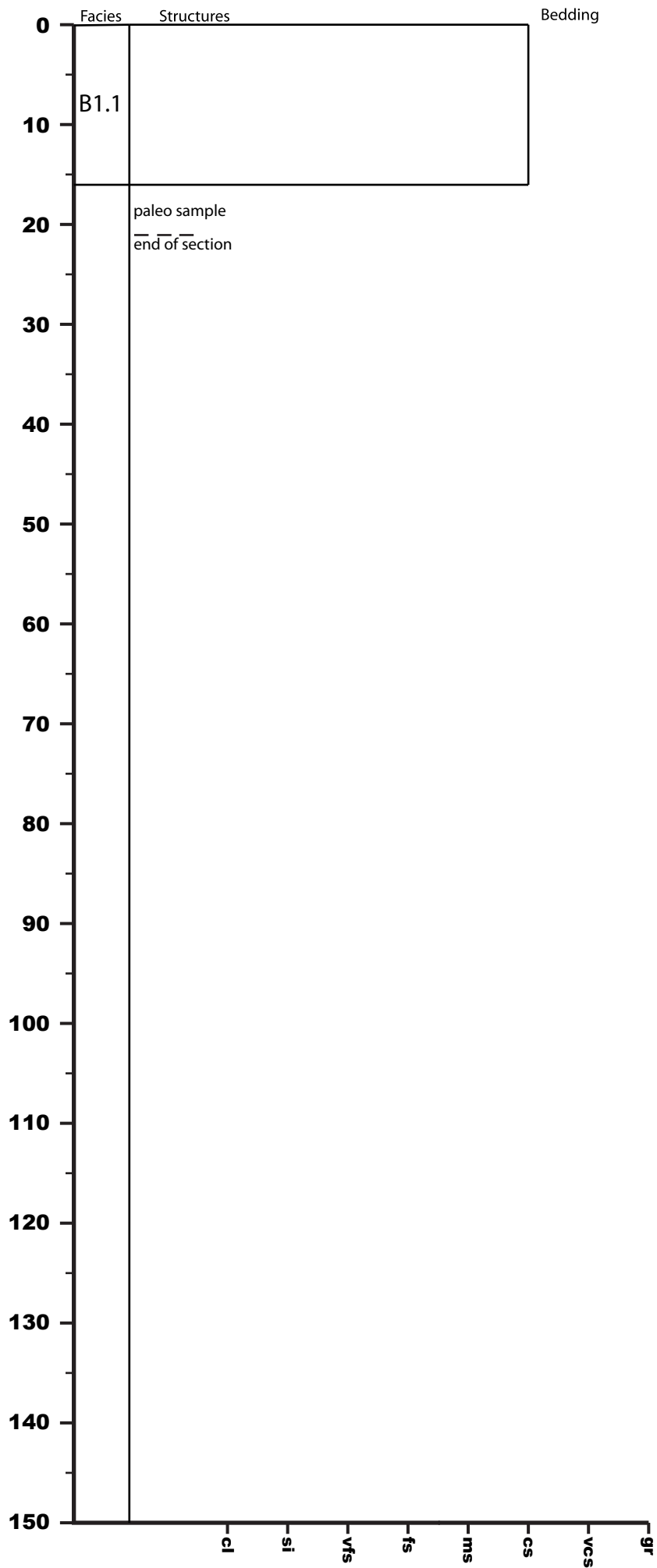

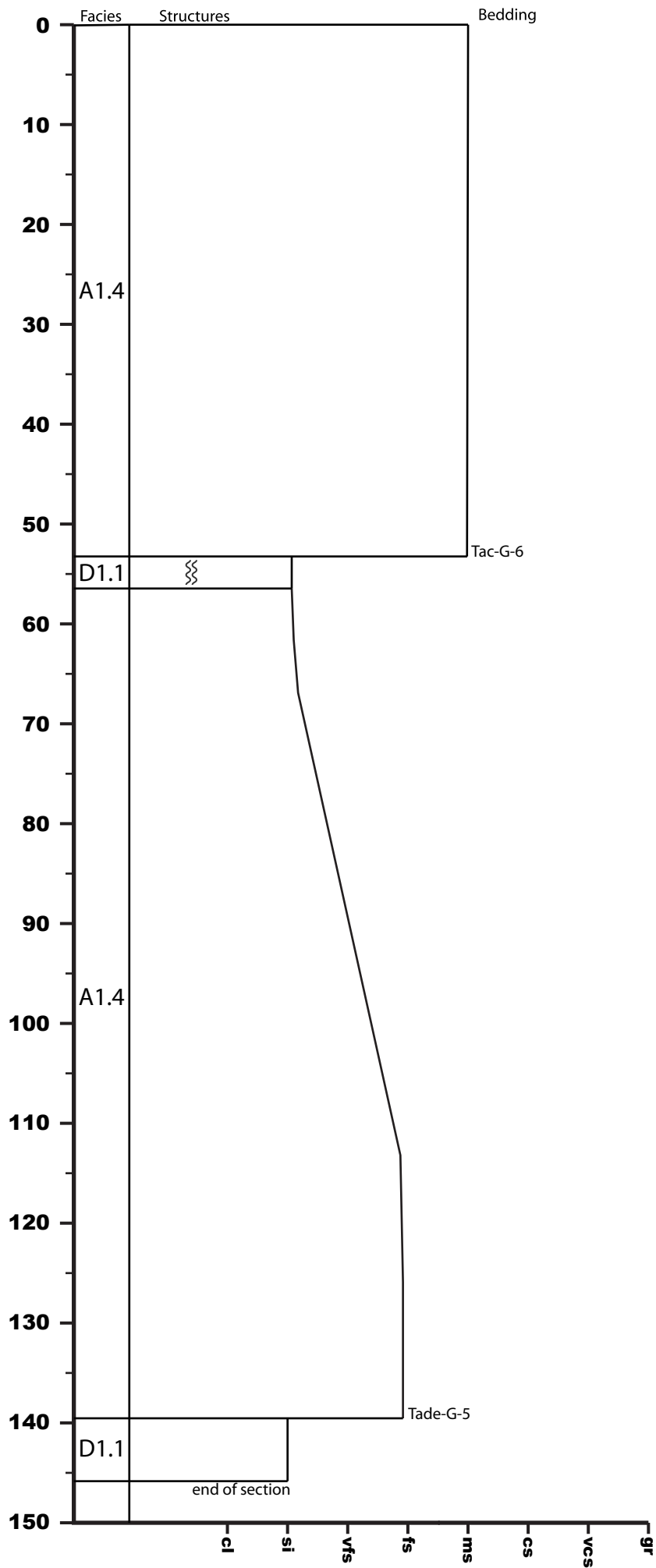

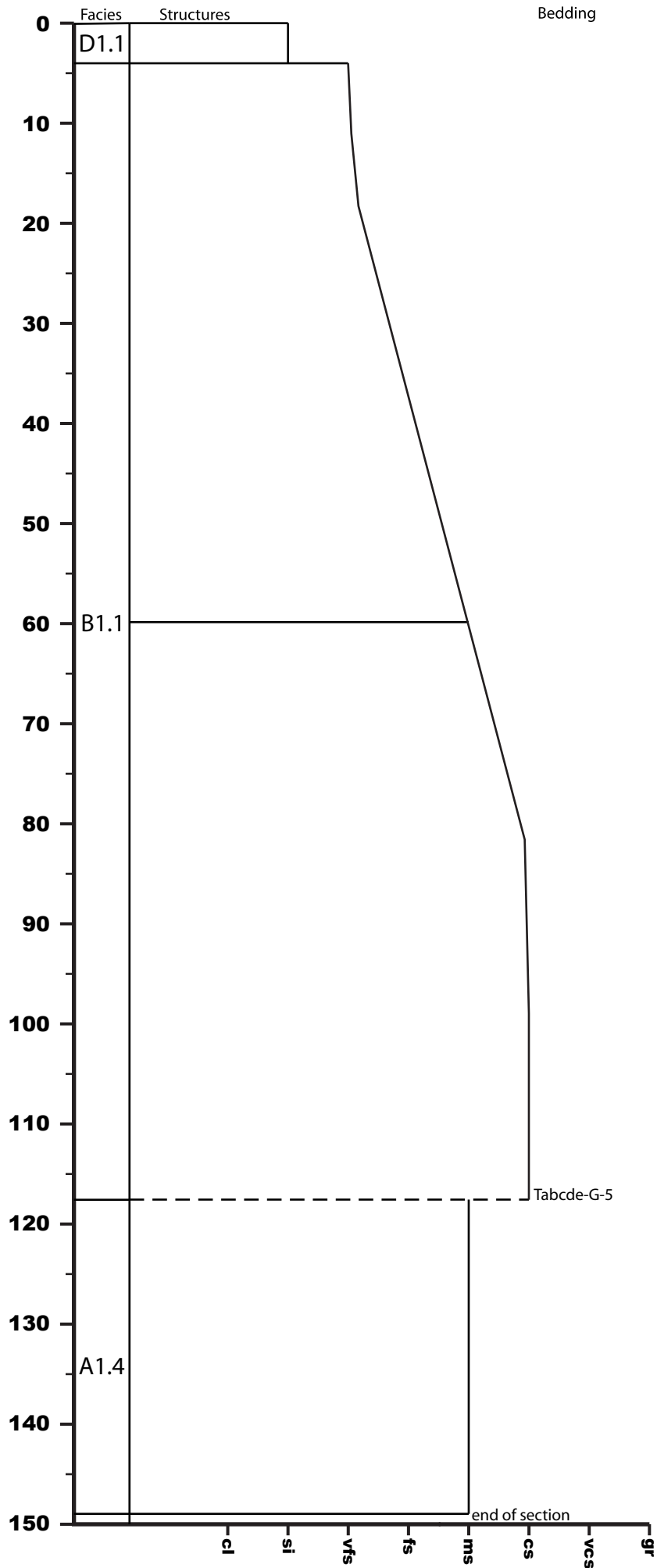

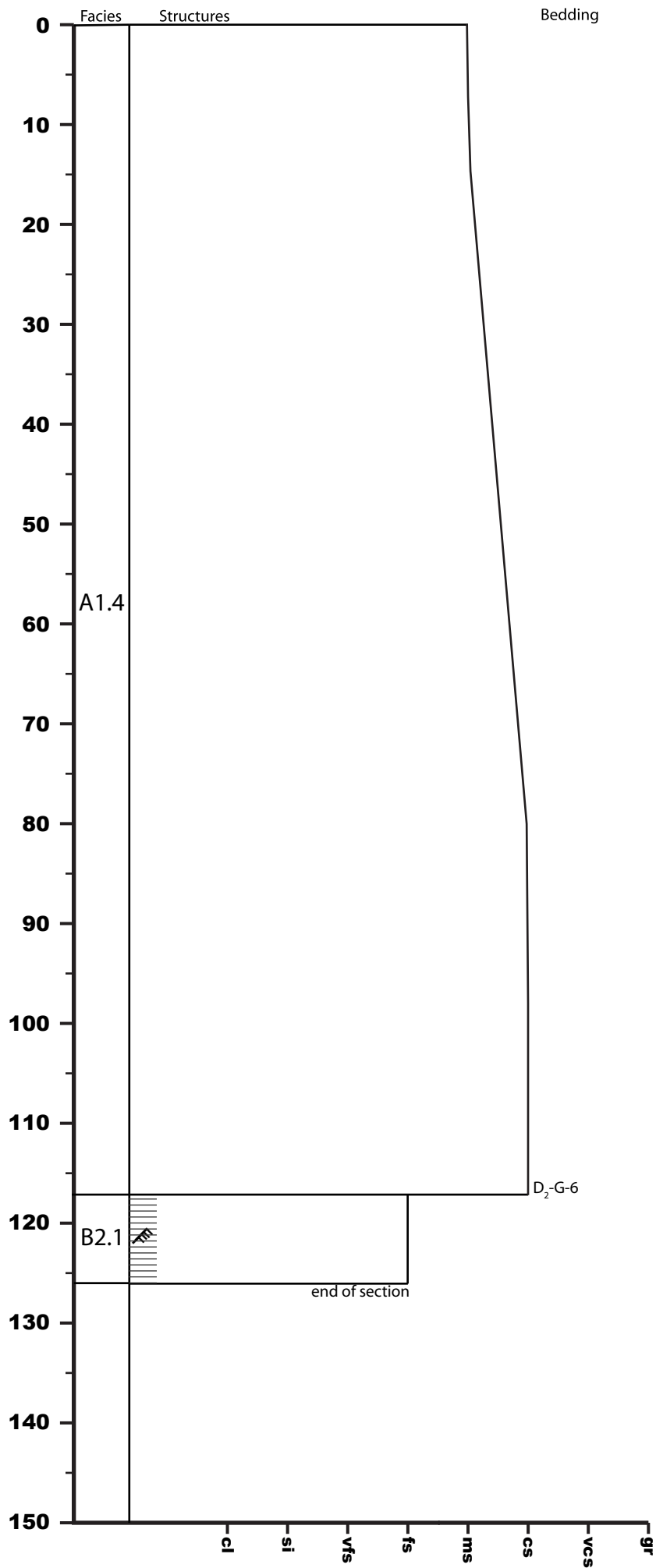

U1438E-11R-4

939.25 - 940.73 mbsf

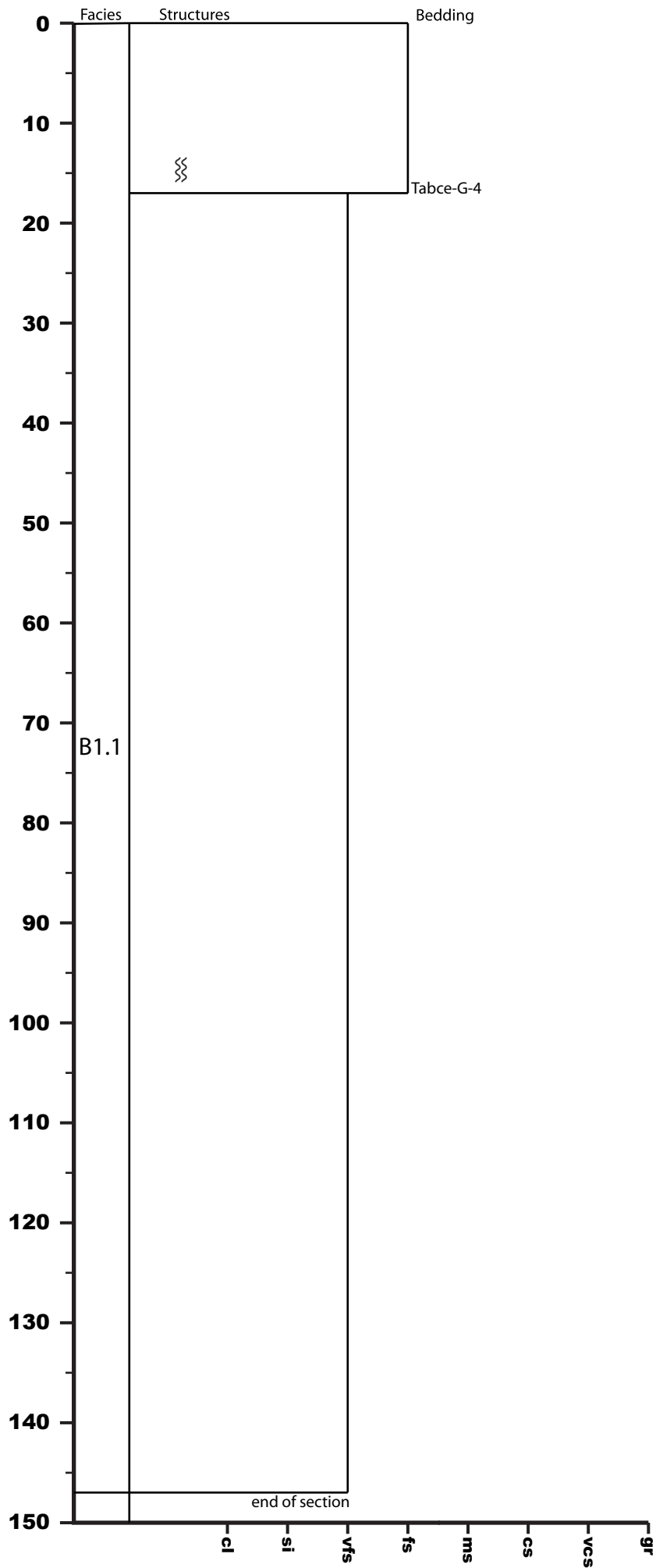



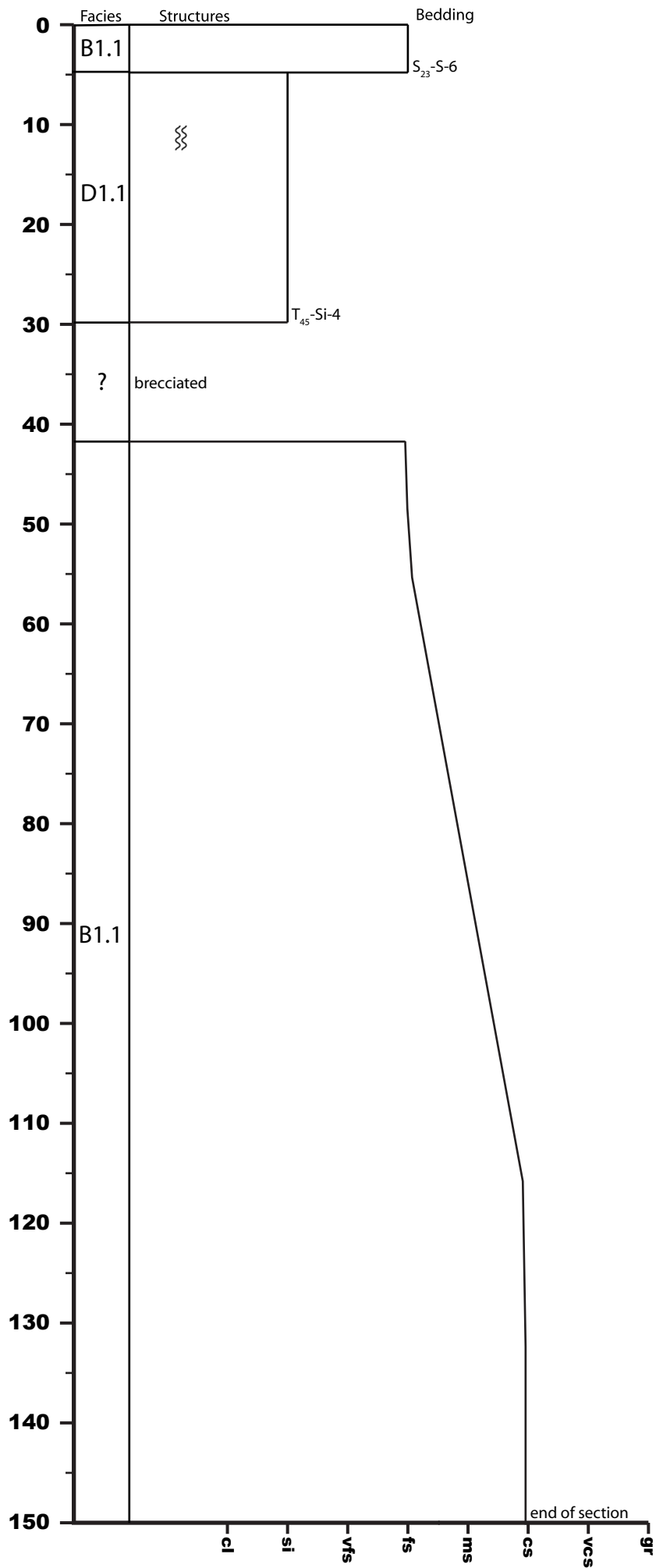

U1438E-11R-6

942.23 - 943.15 mbsf

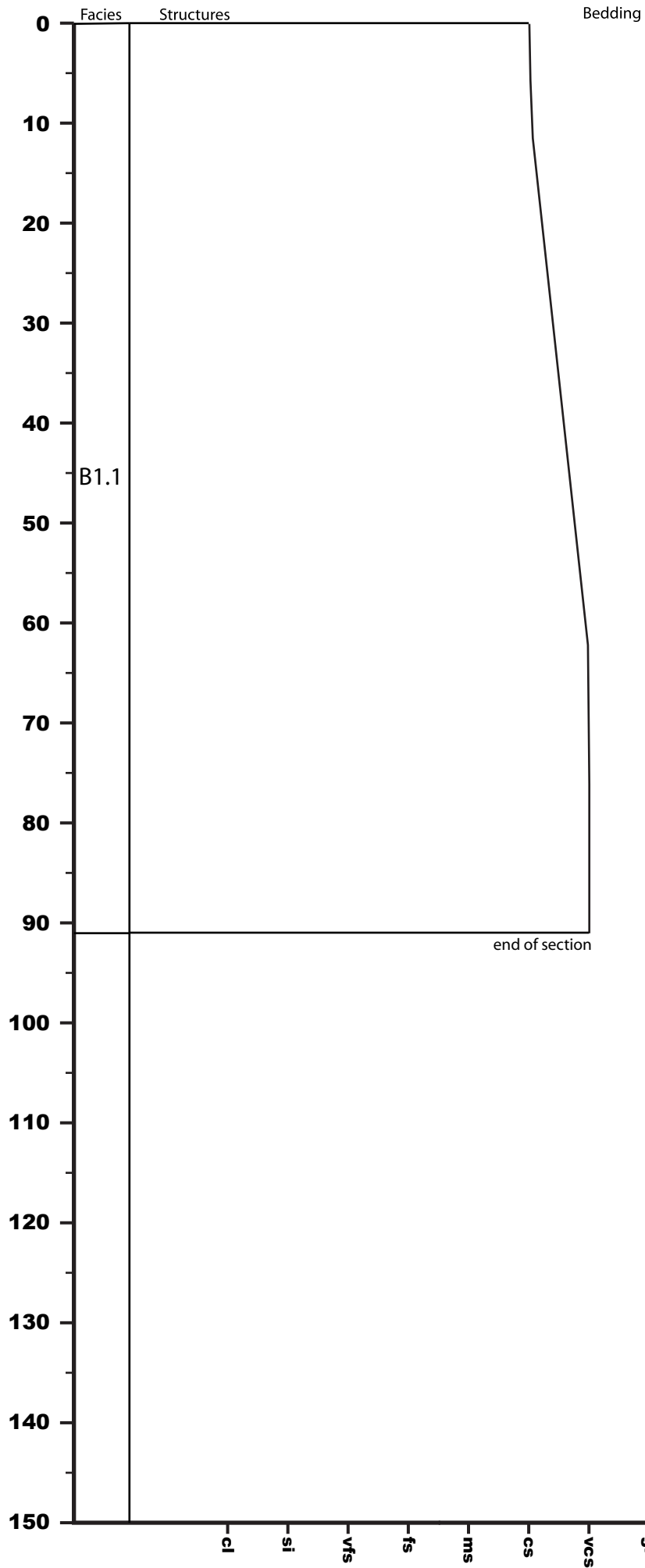

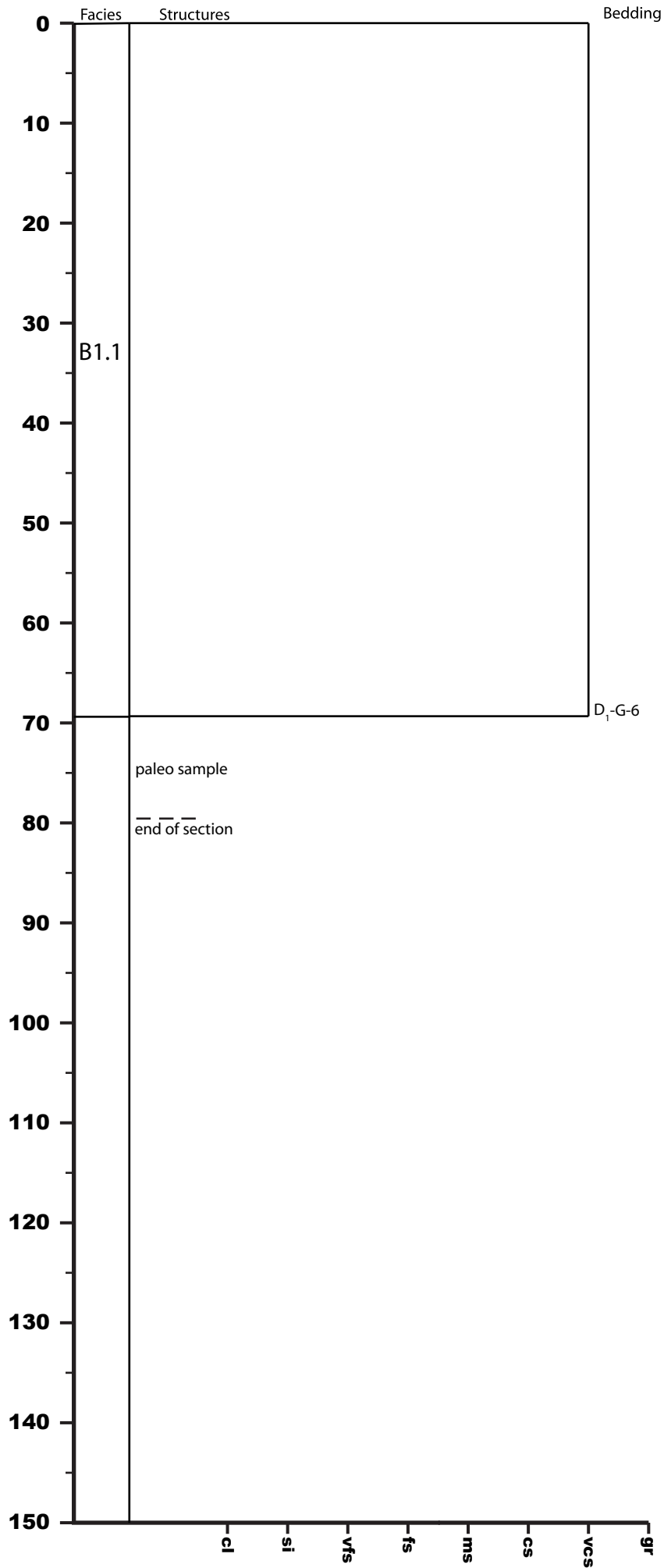

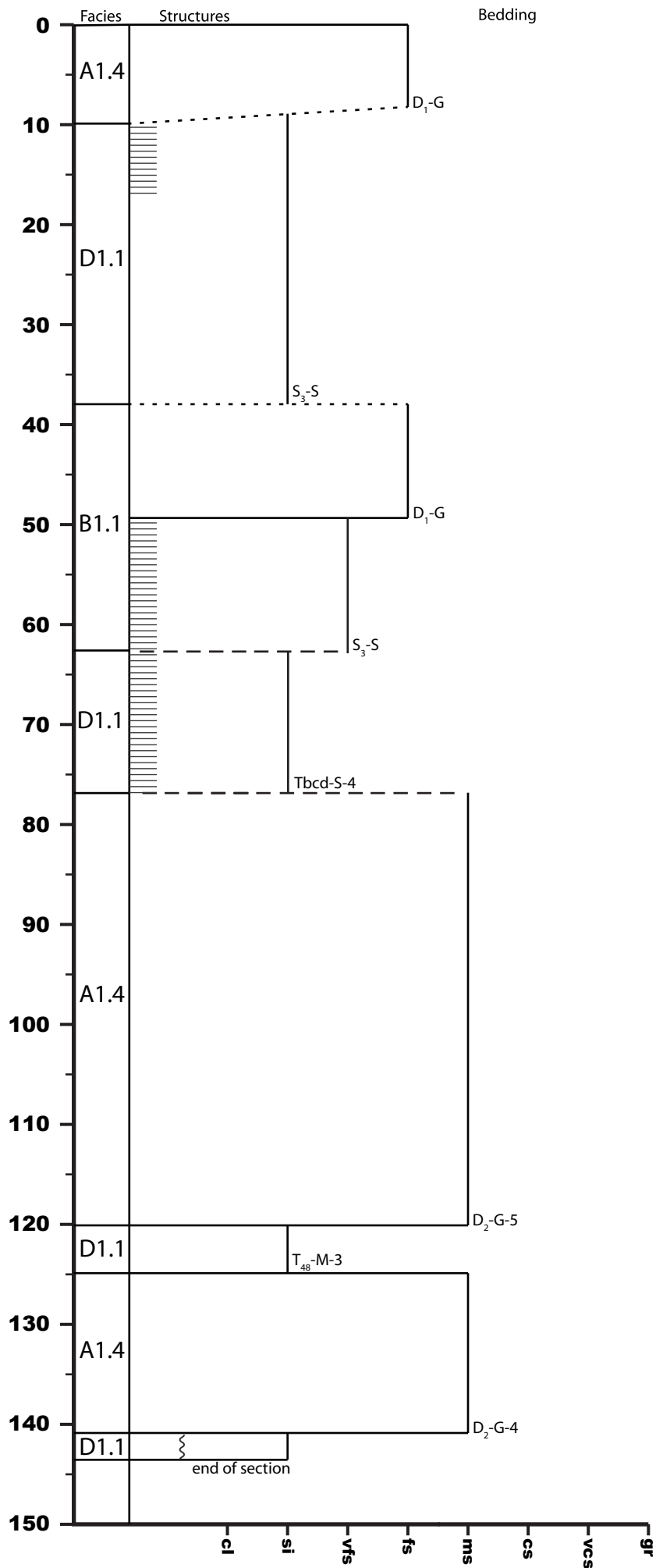

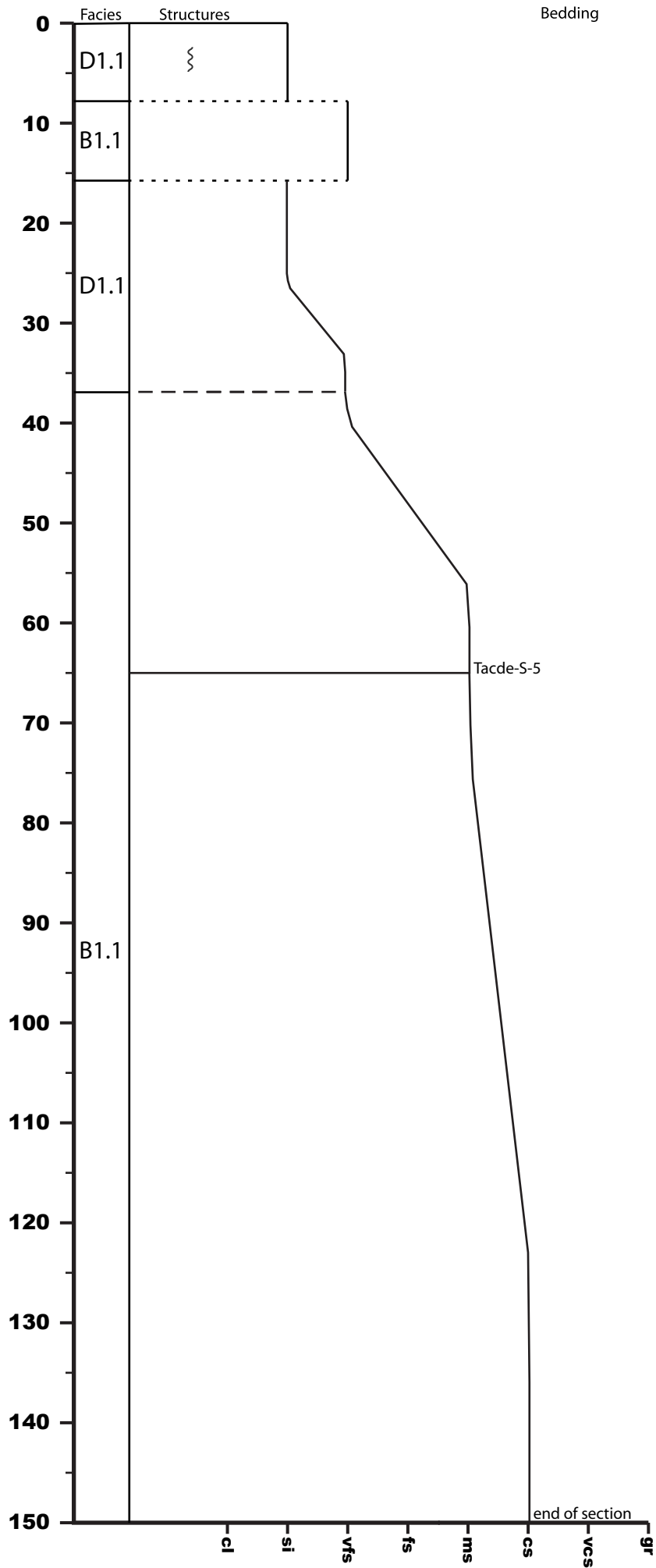

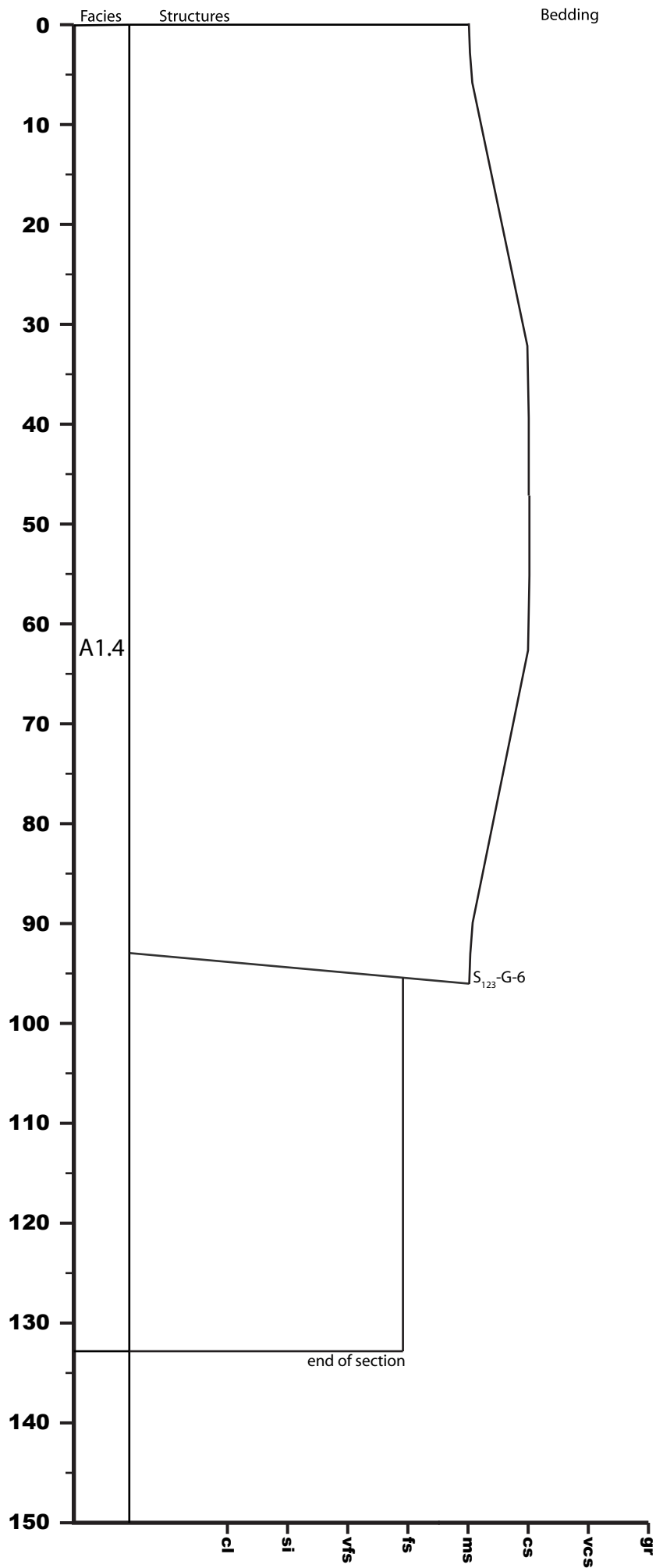

U1438E-12R-4

948.98 - 950.65 mbsf

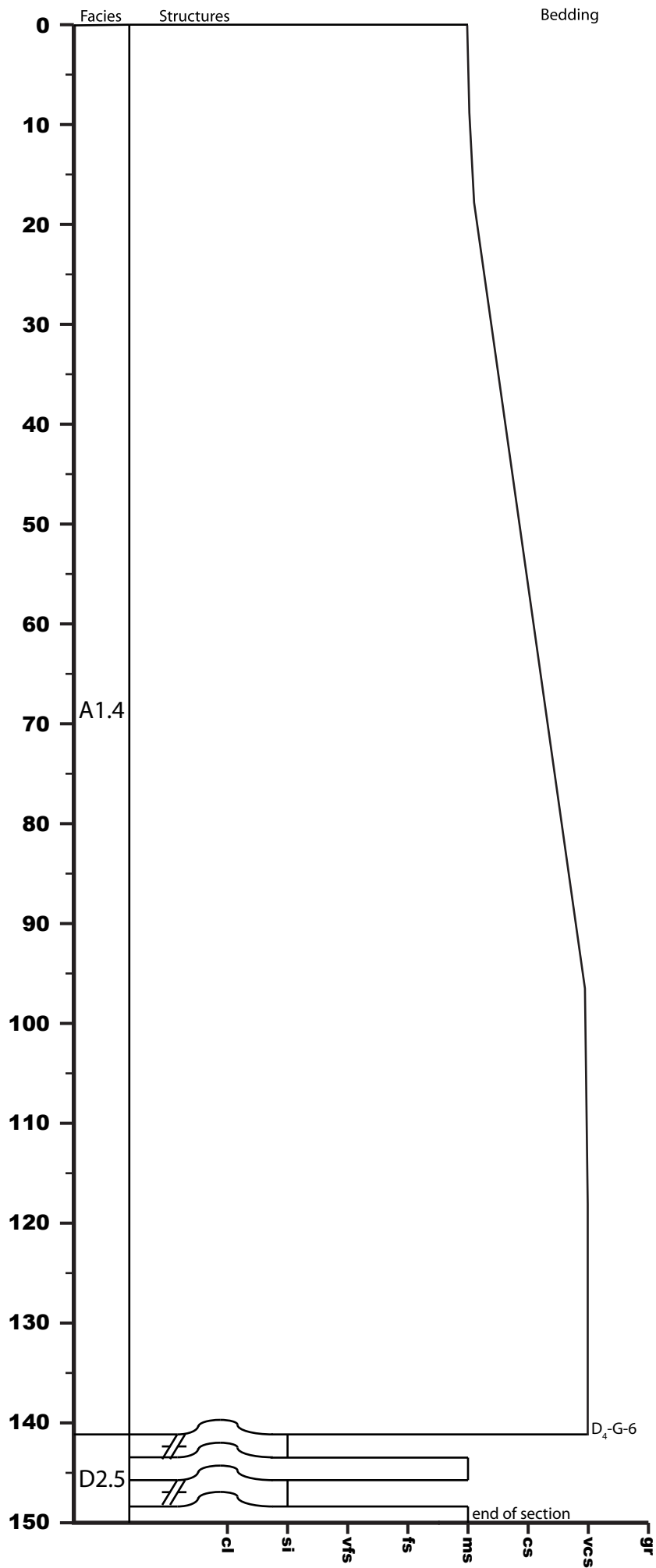

U1438E-12R-5

950.65 - 952.15 mbsf

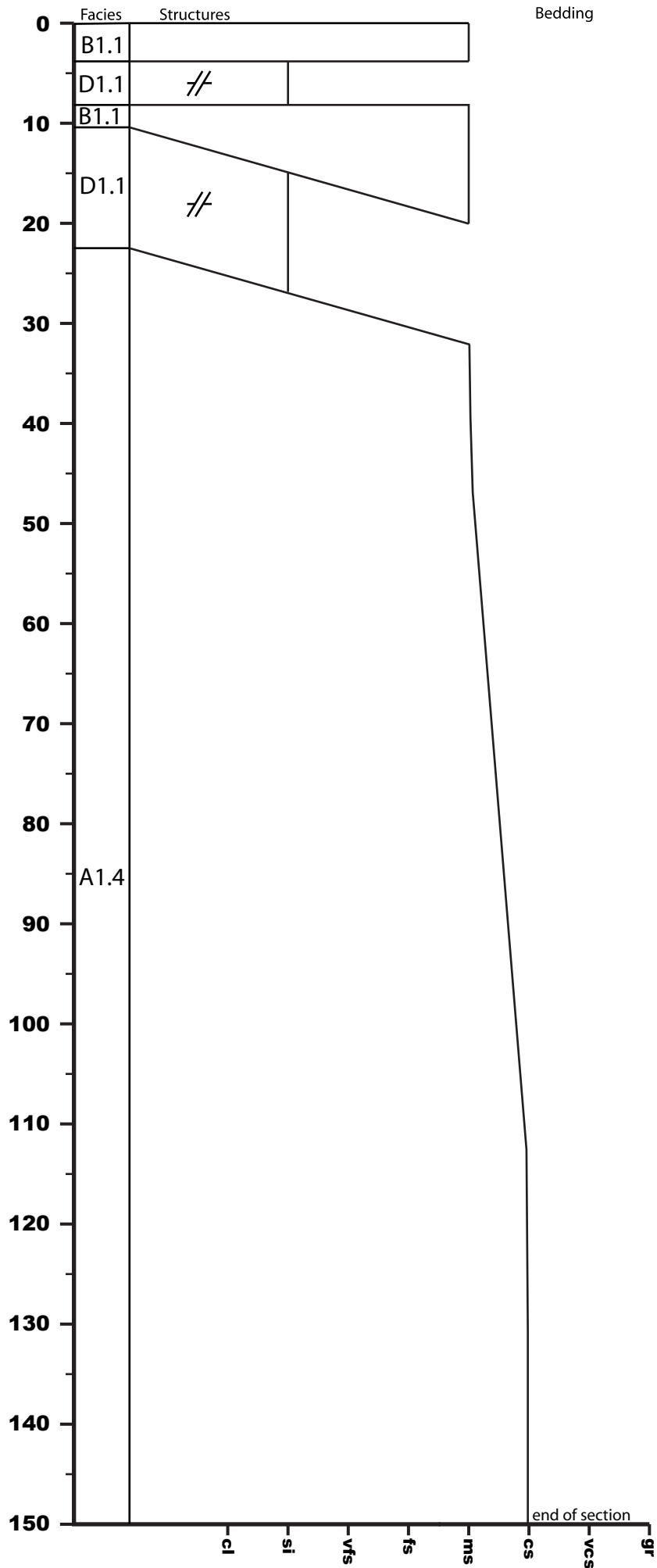



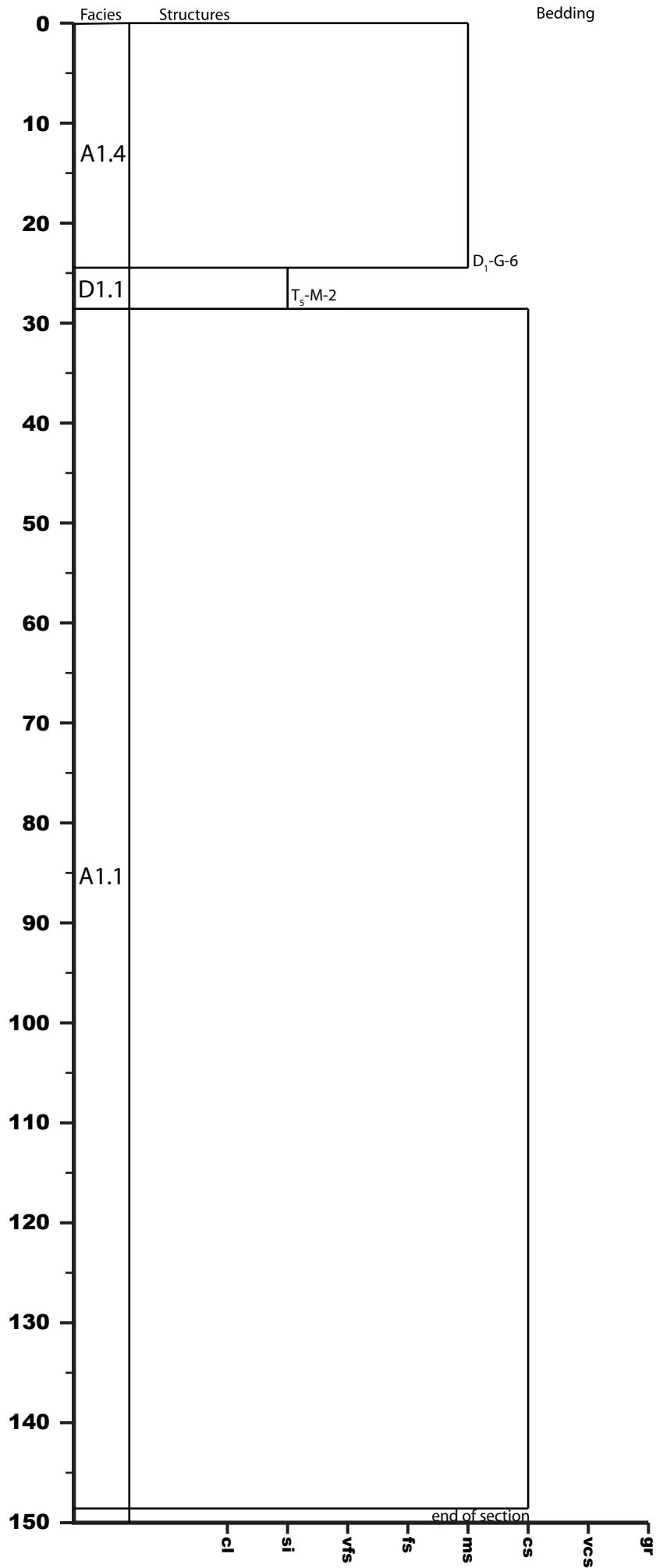

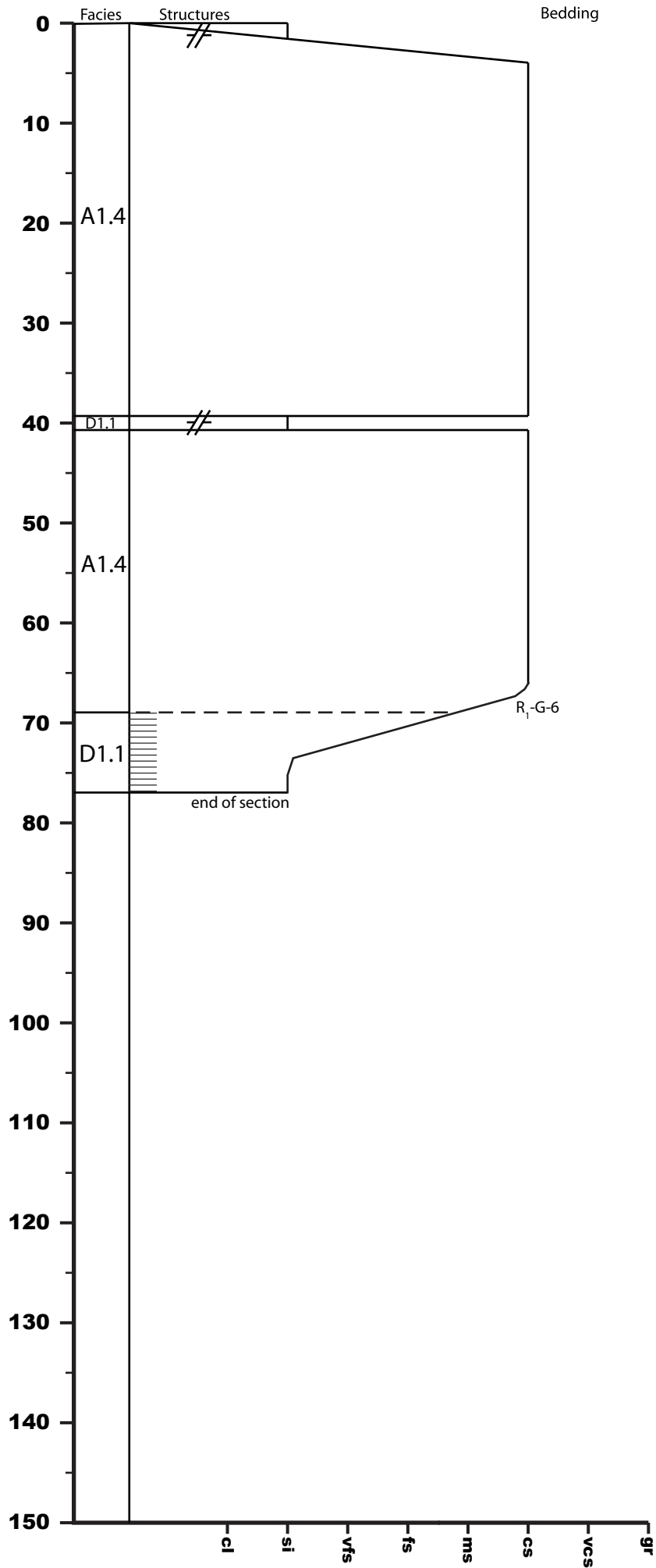

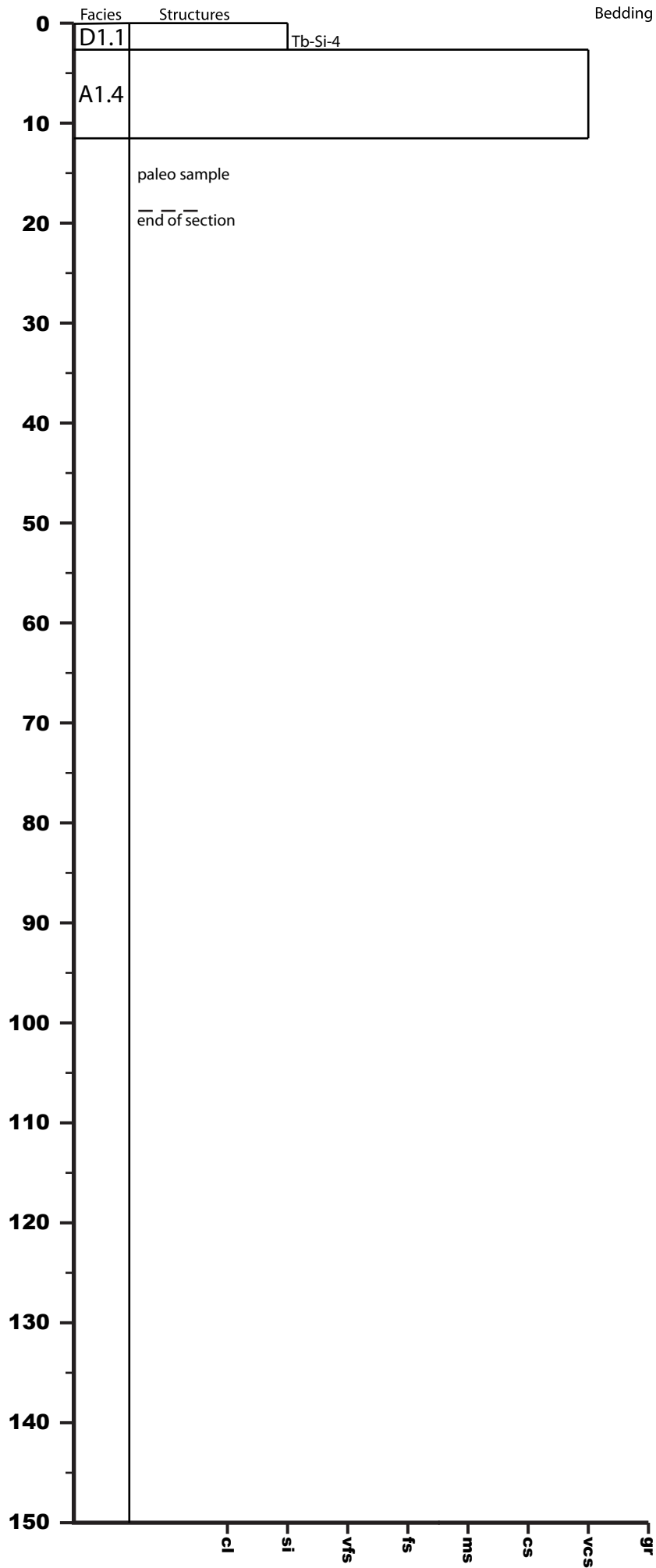

U1438E-13R-1

954.4 - 955.73 mbsf

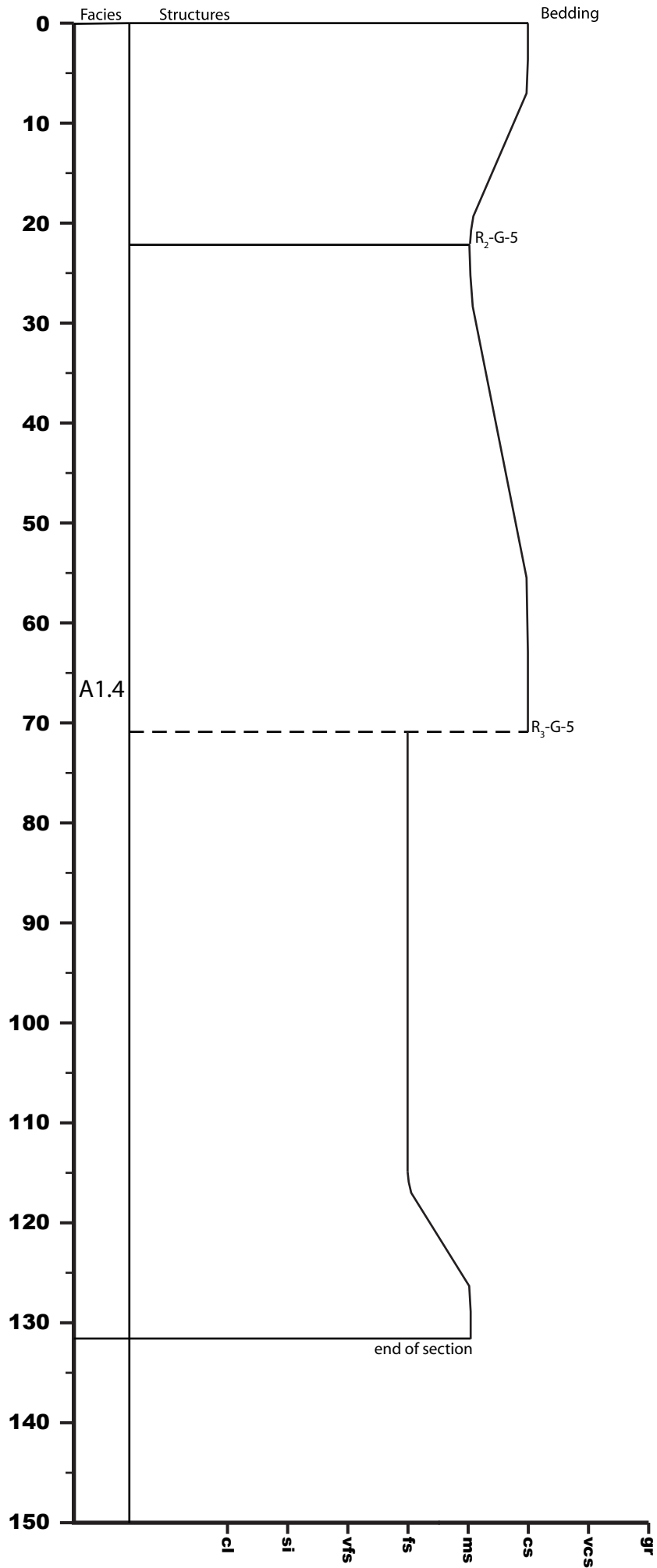

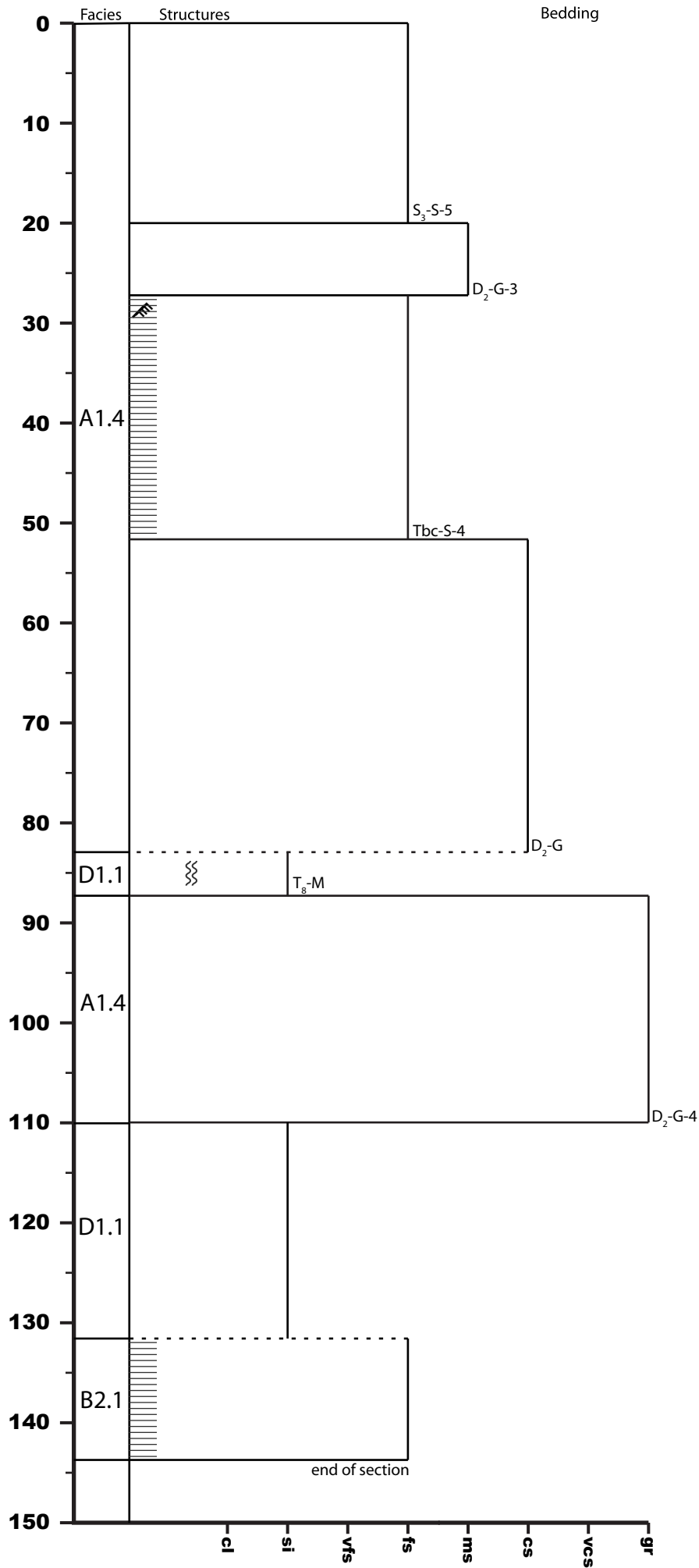

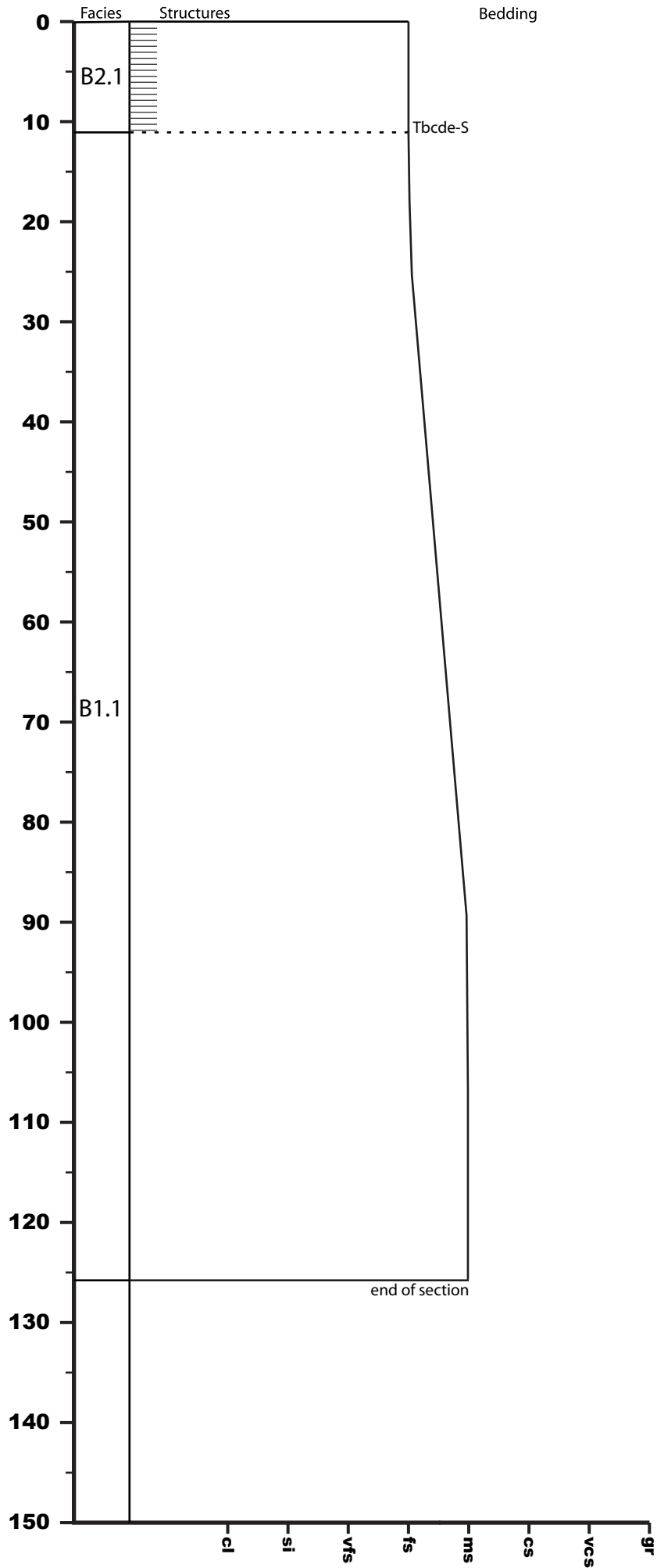

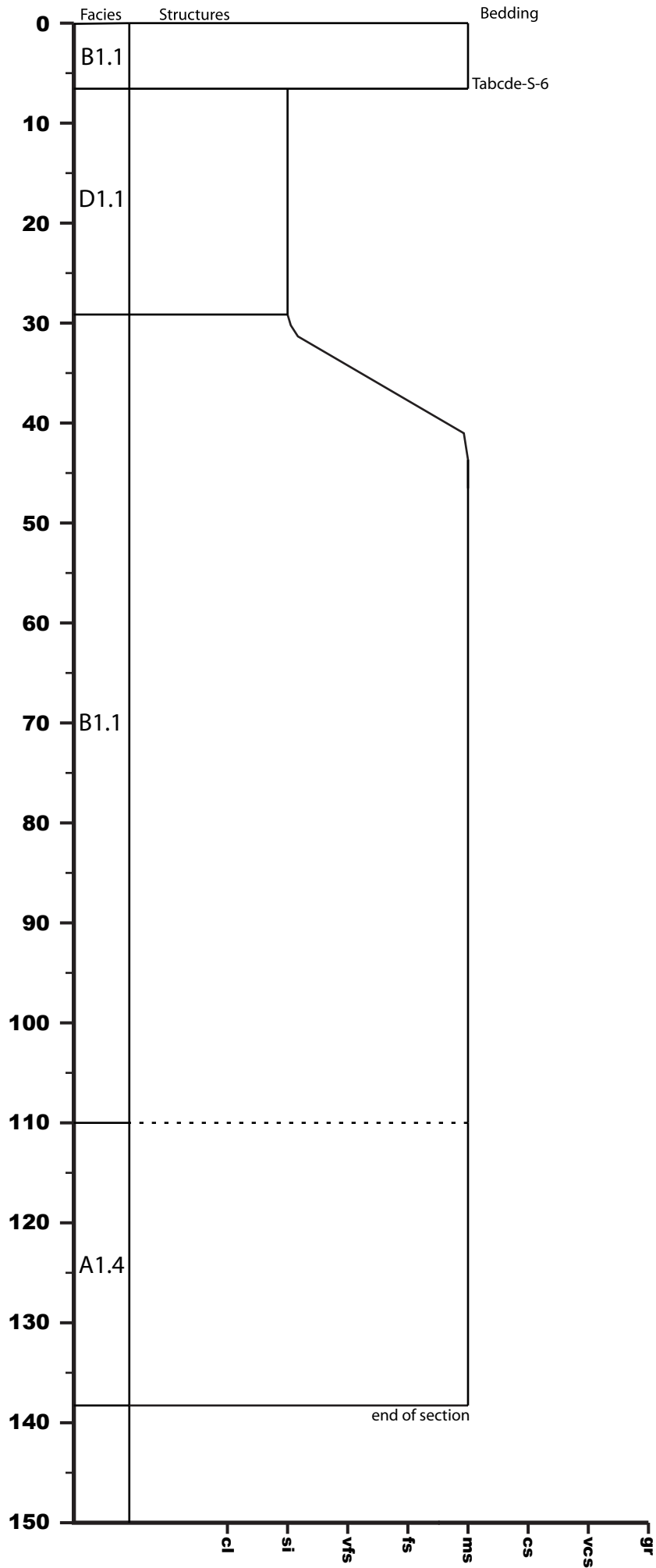

U1438E-13R-5

959.52 - 961.22 mbsf

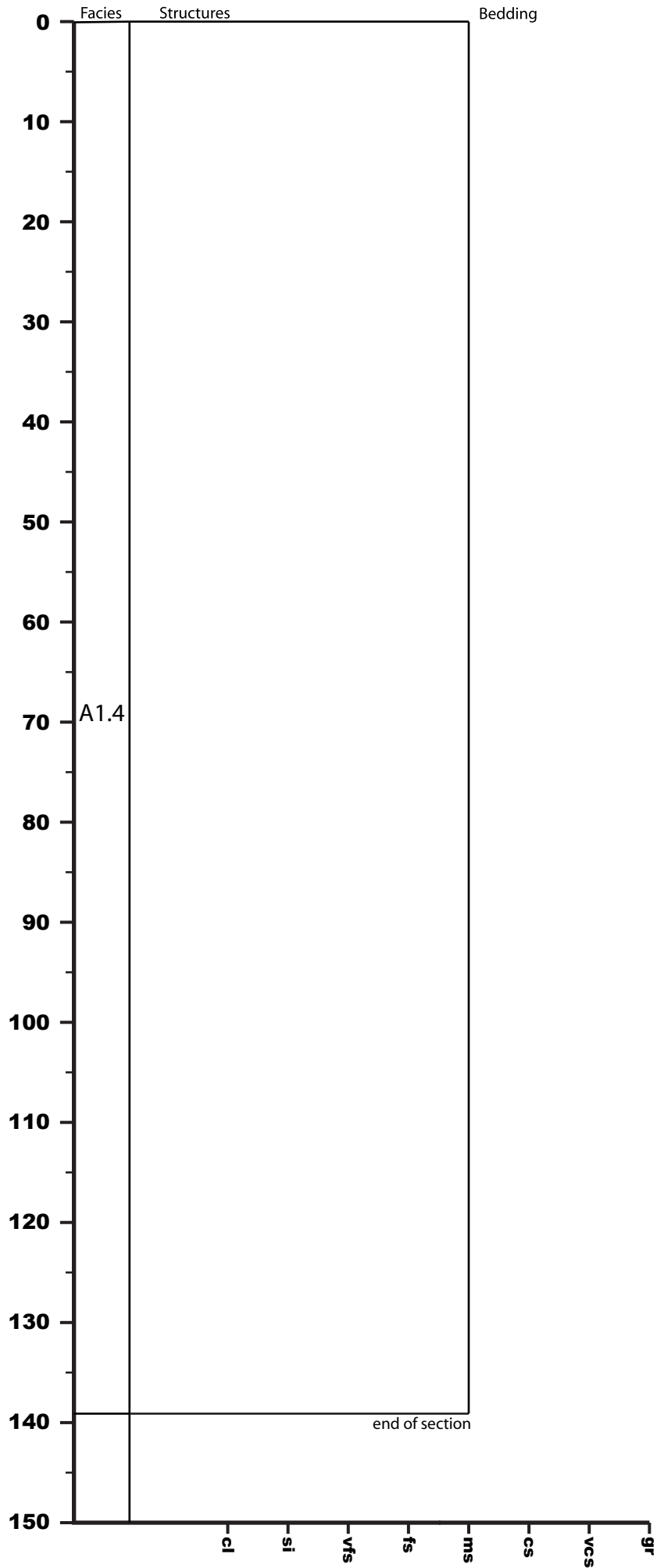



U1438E-13R-6

961.22 - 962.2 mbsf

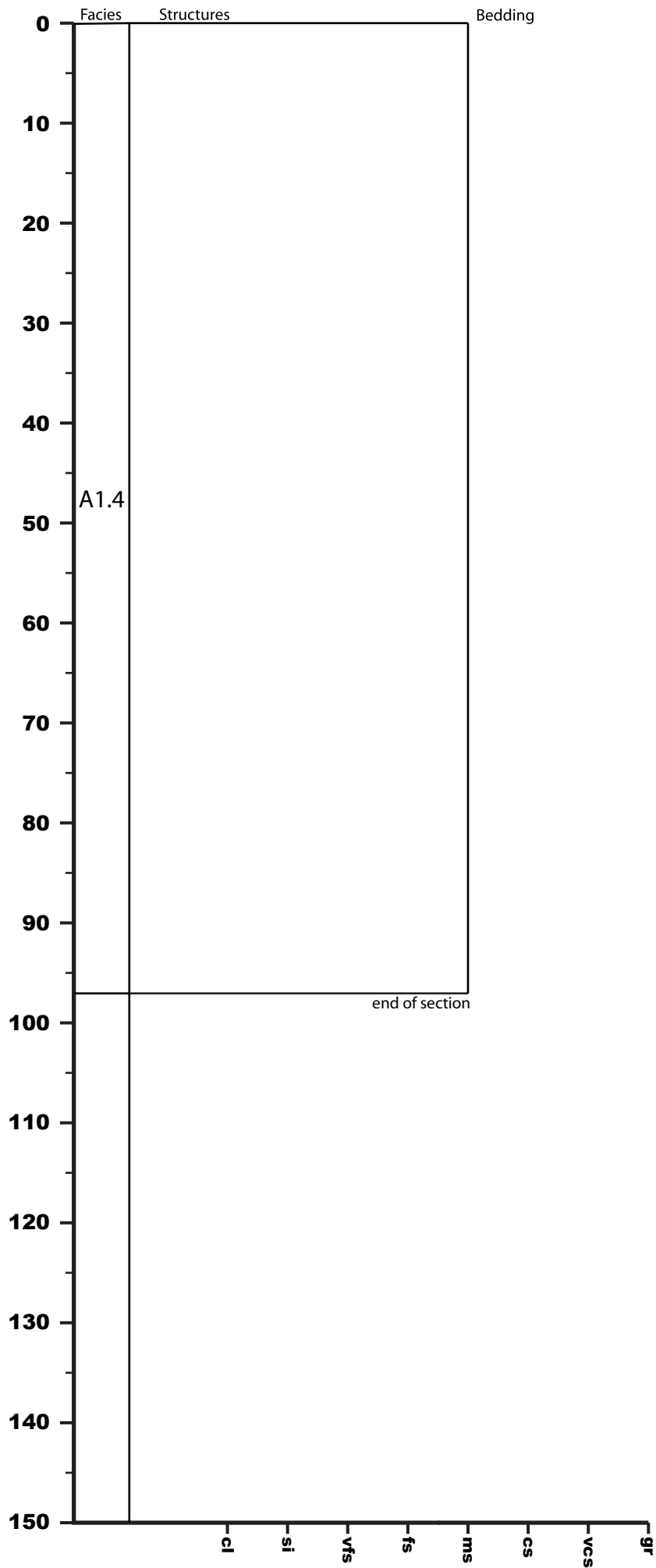

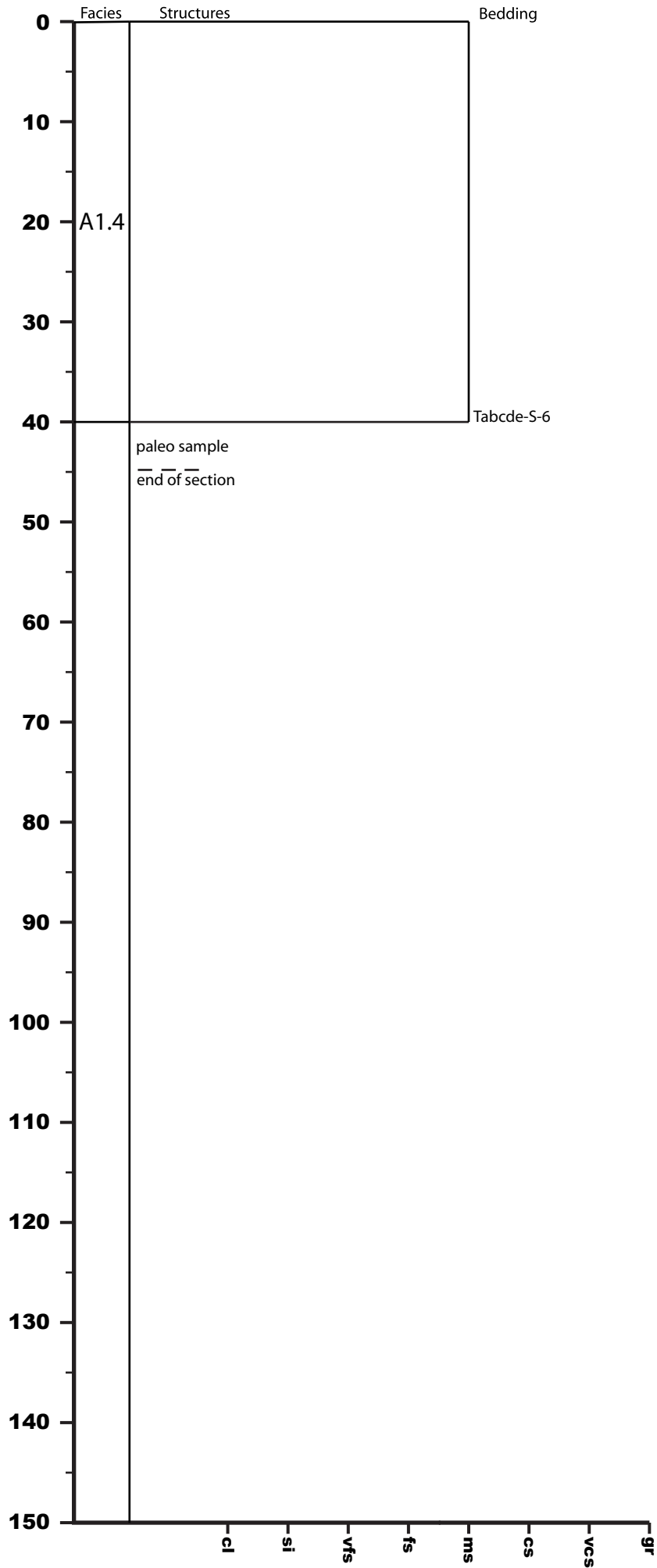

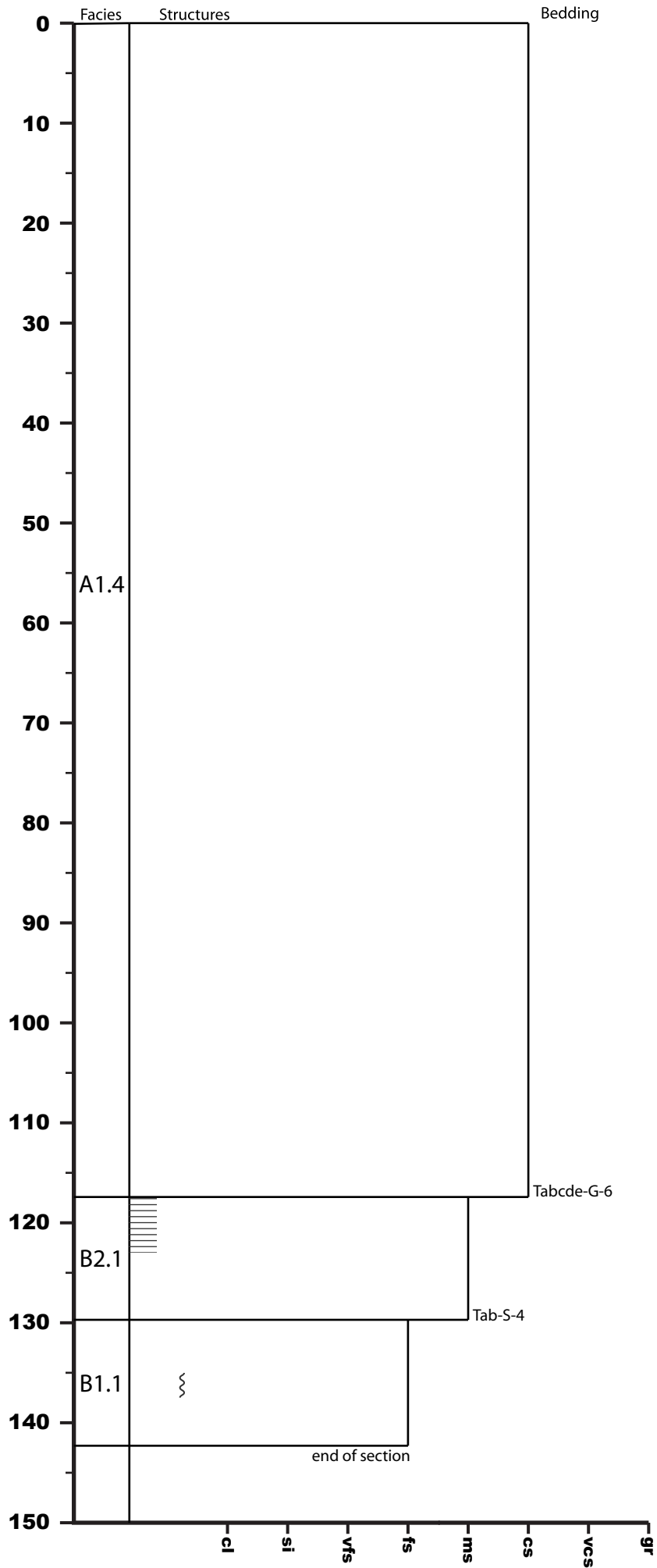

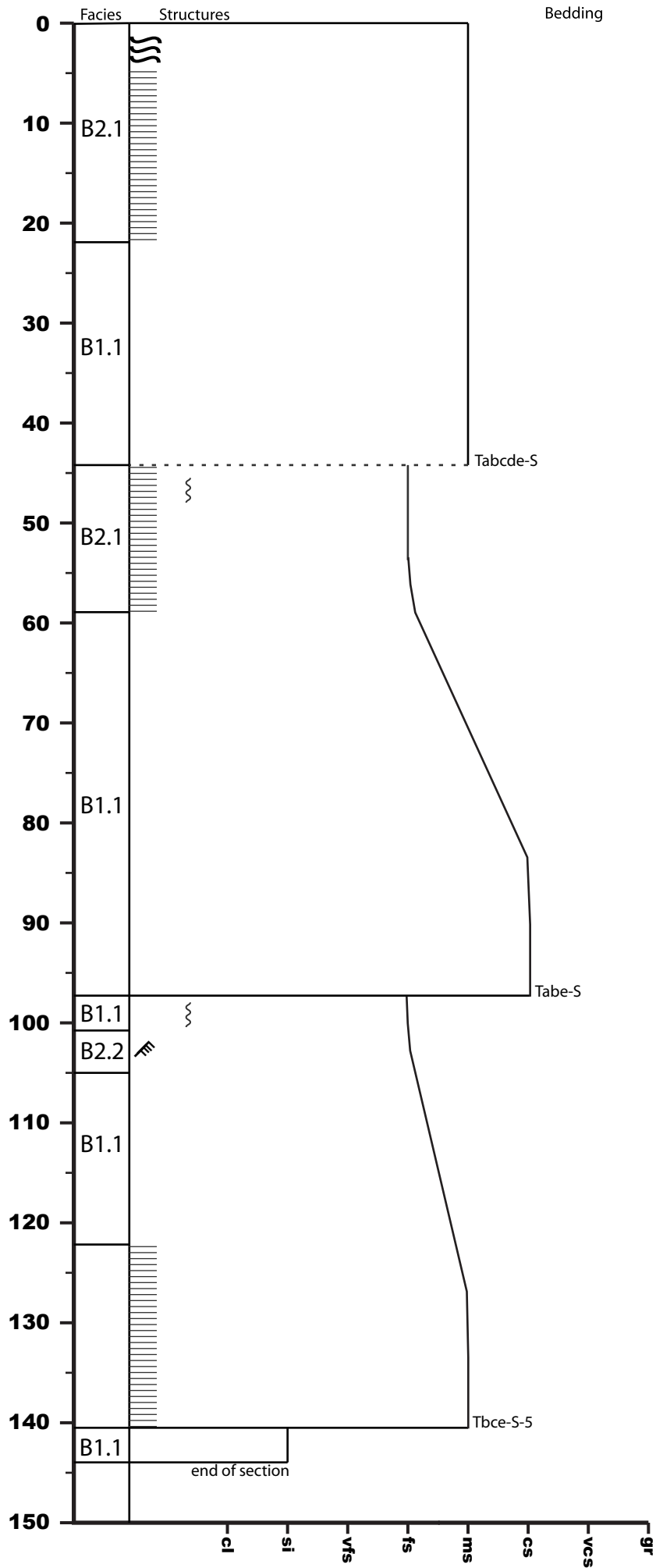

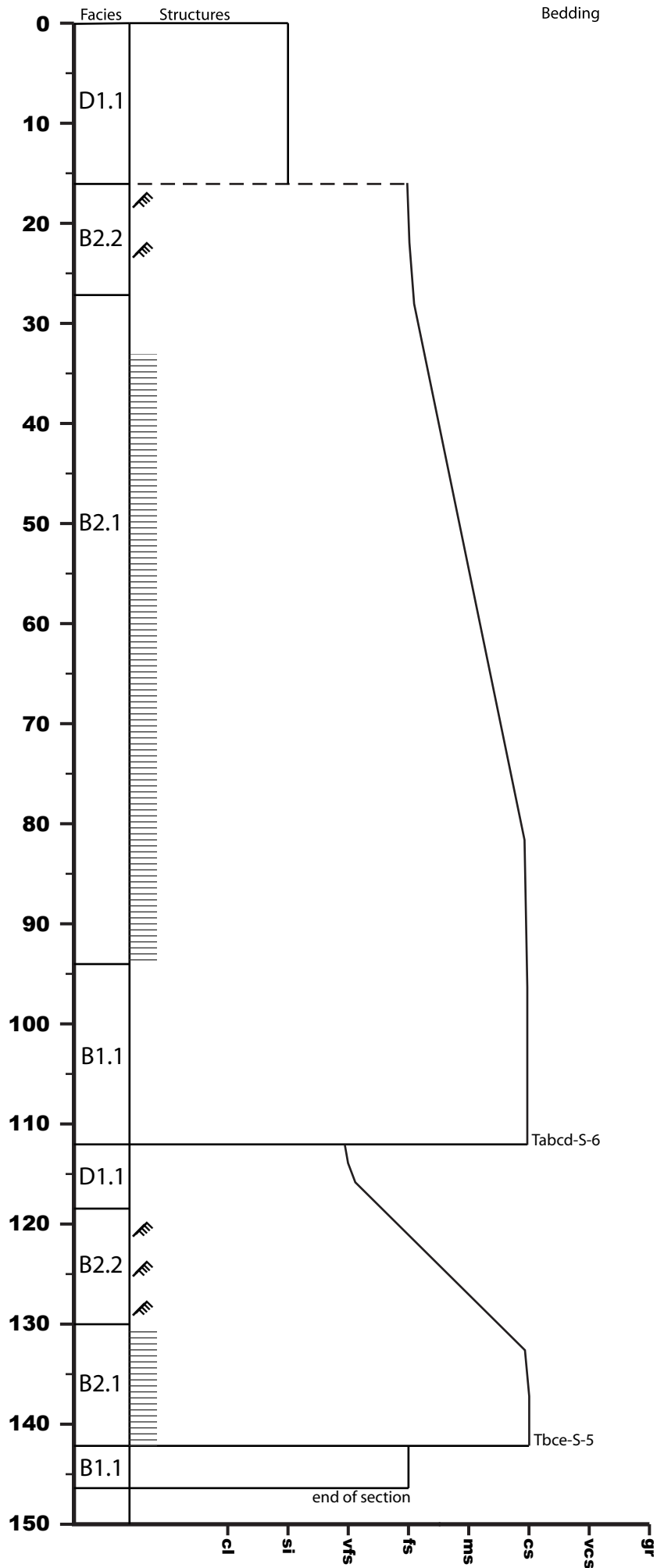

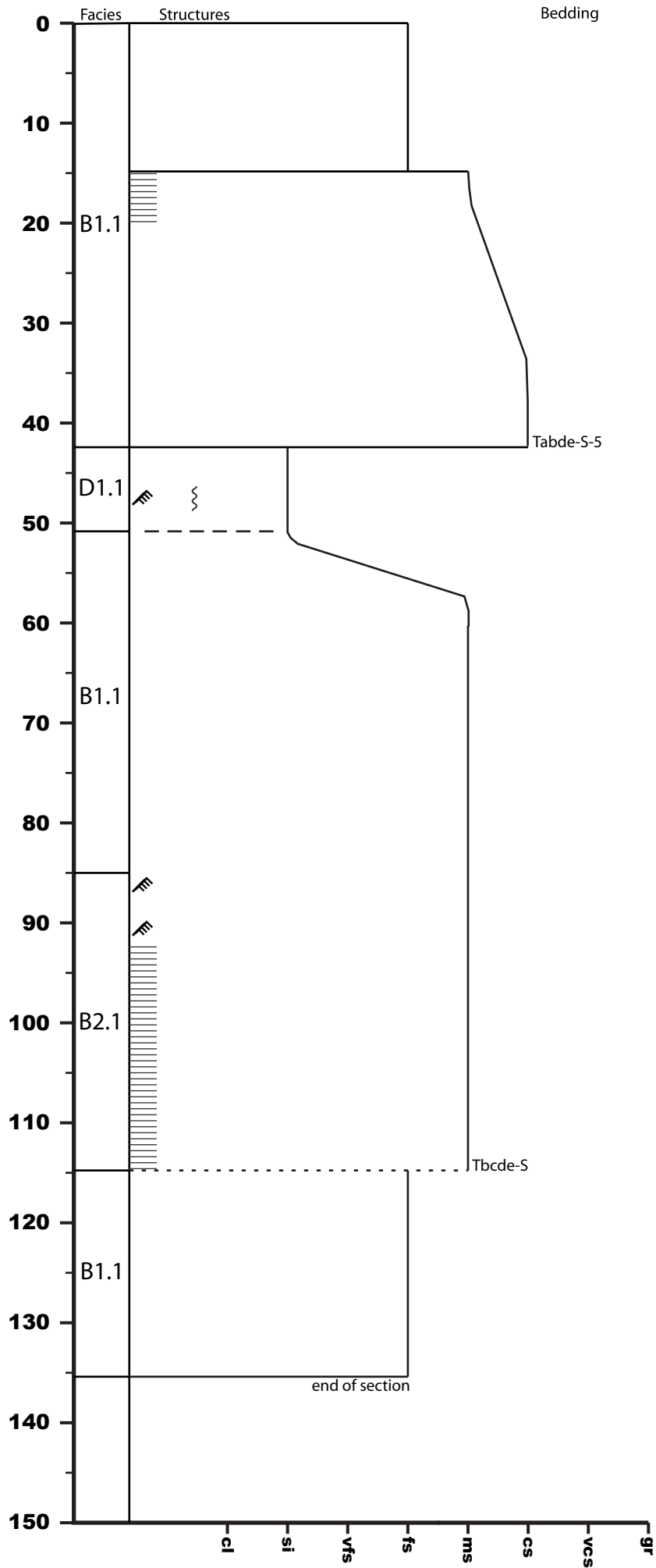

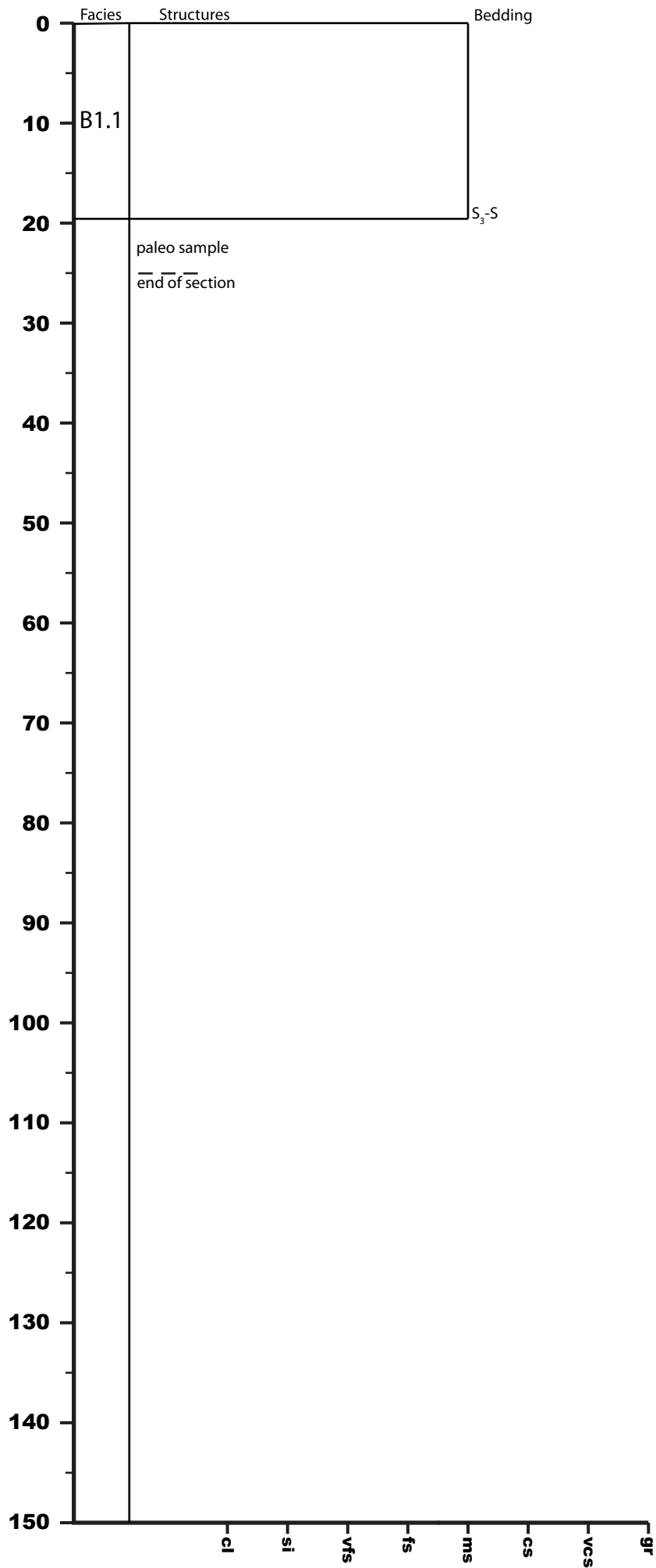

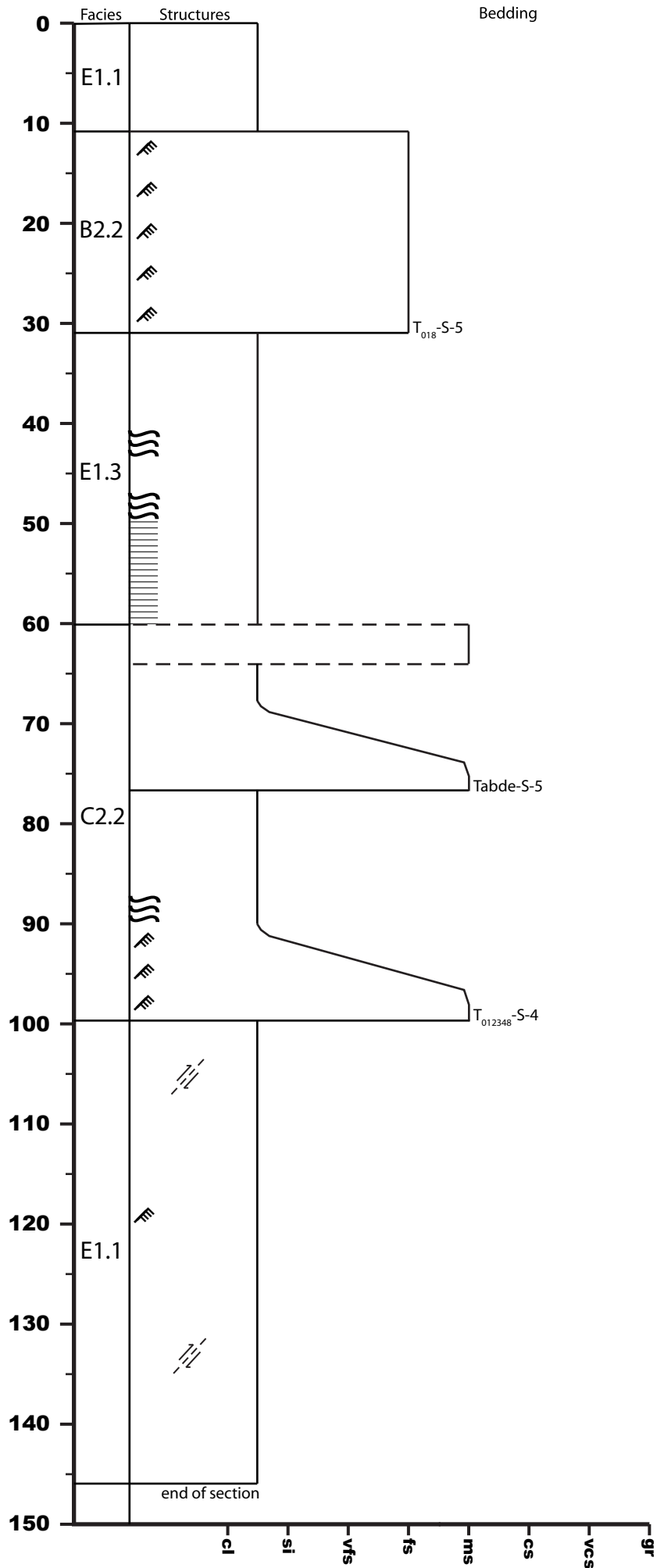



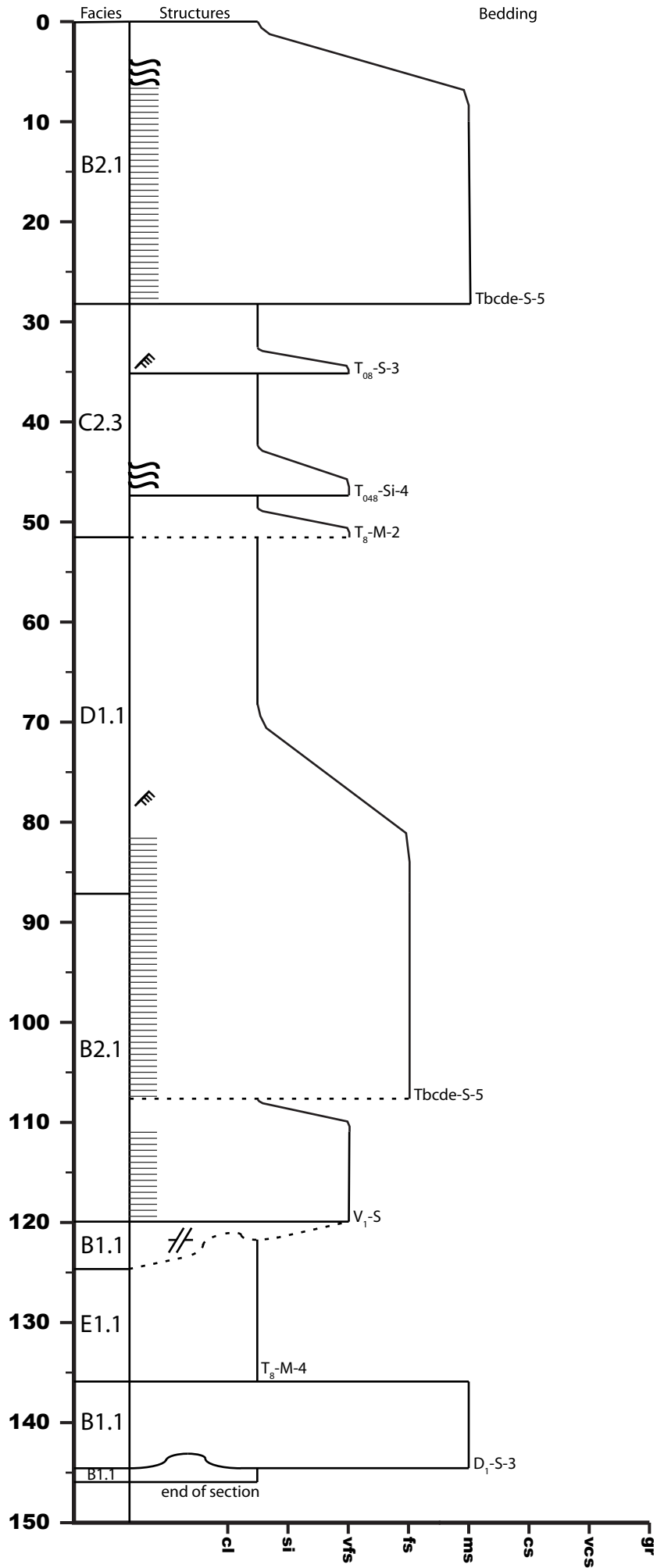

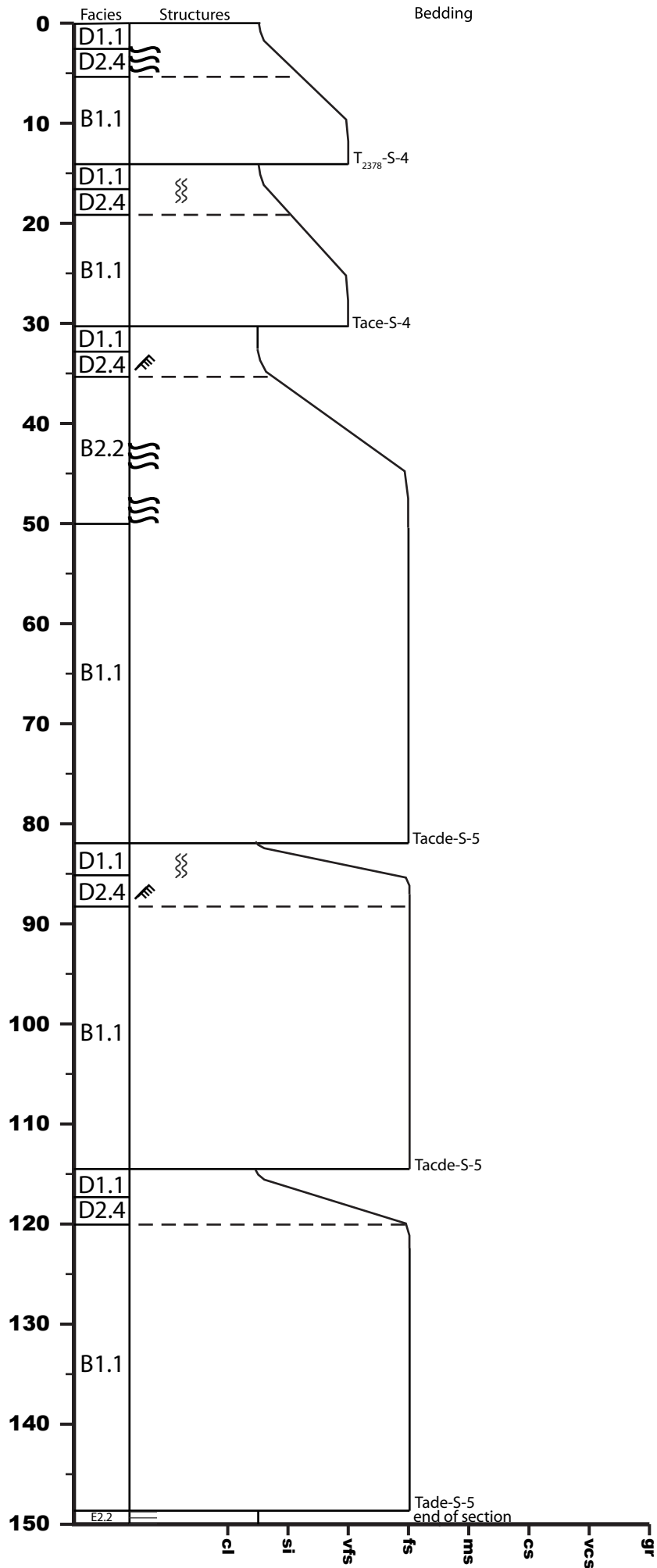

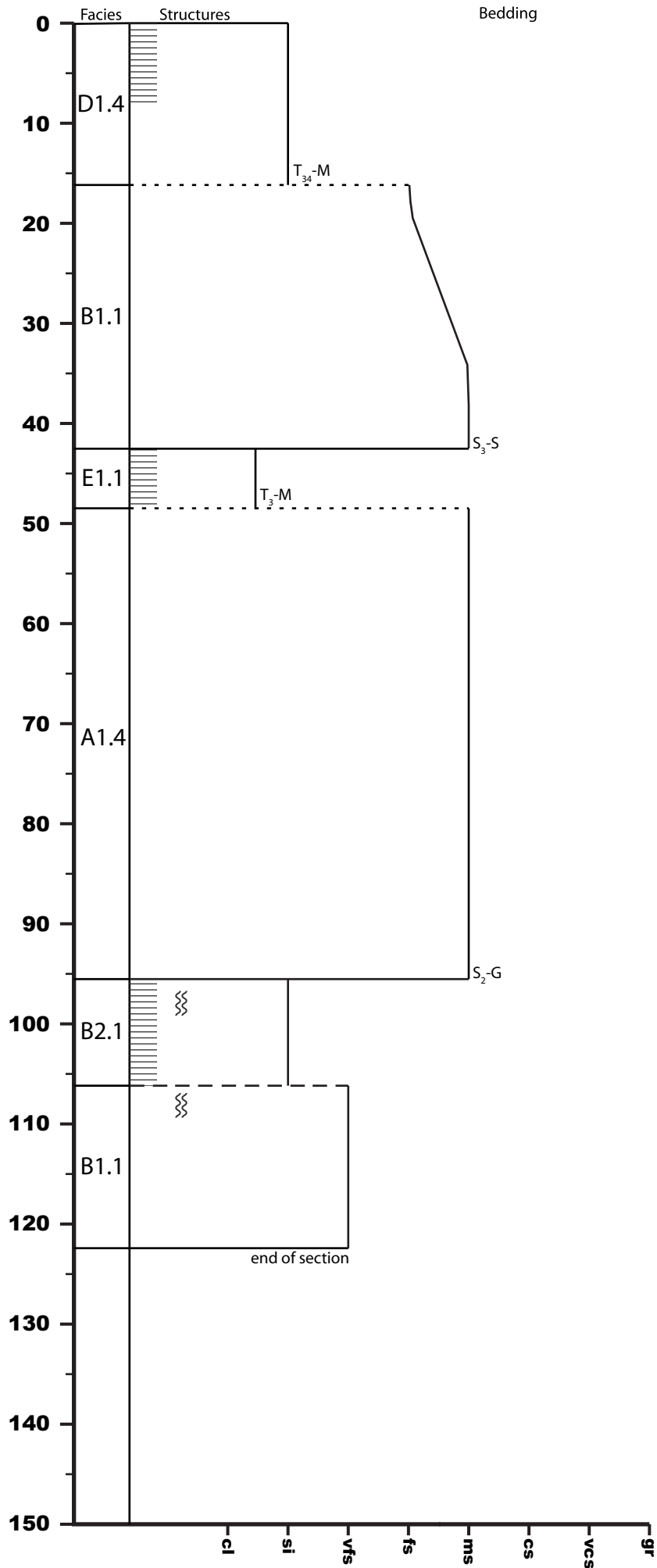

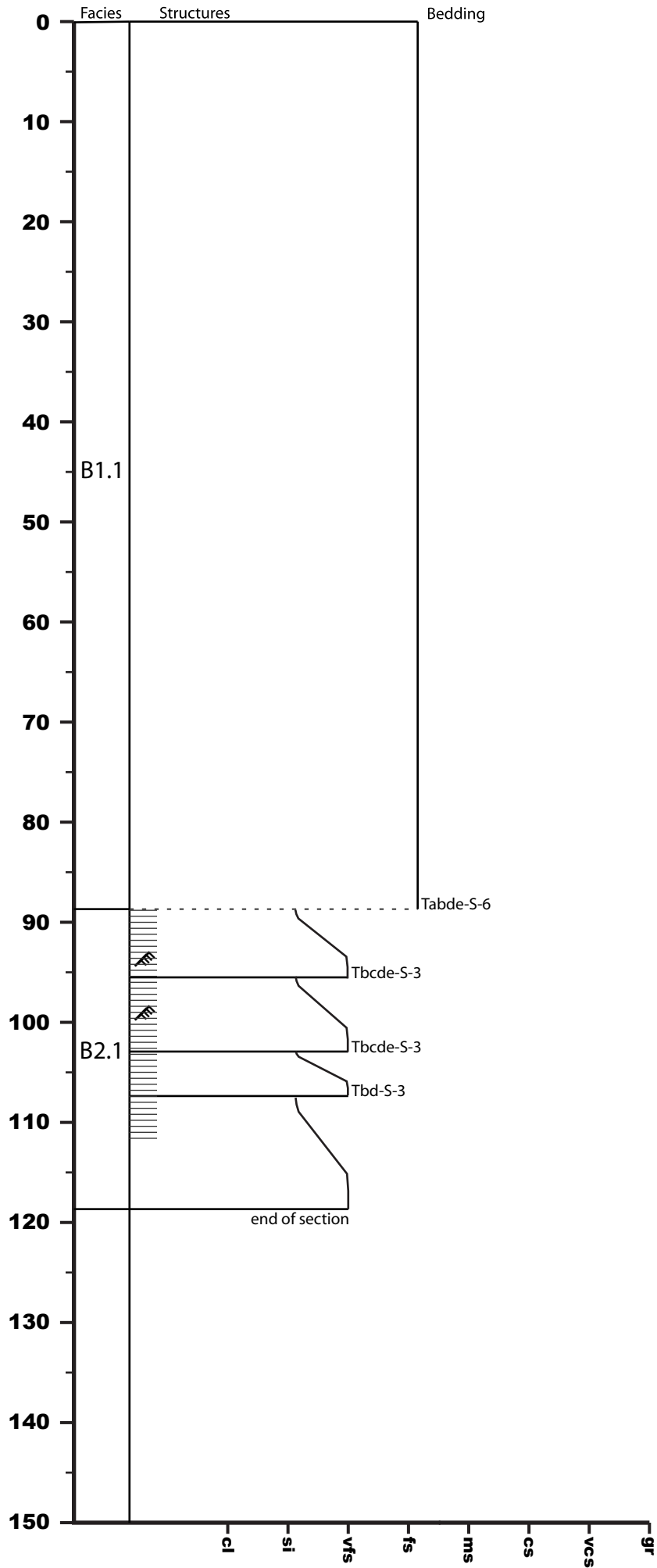

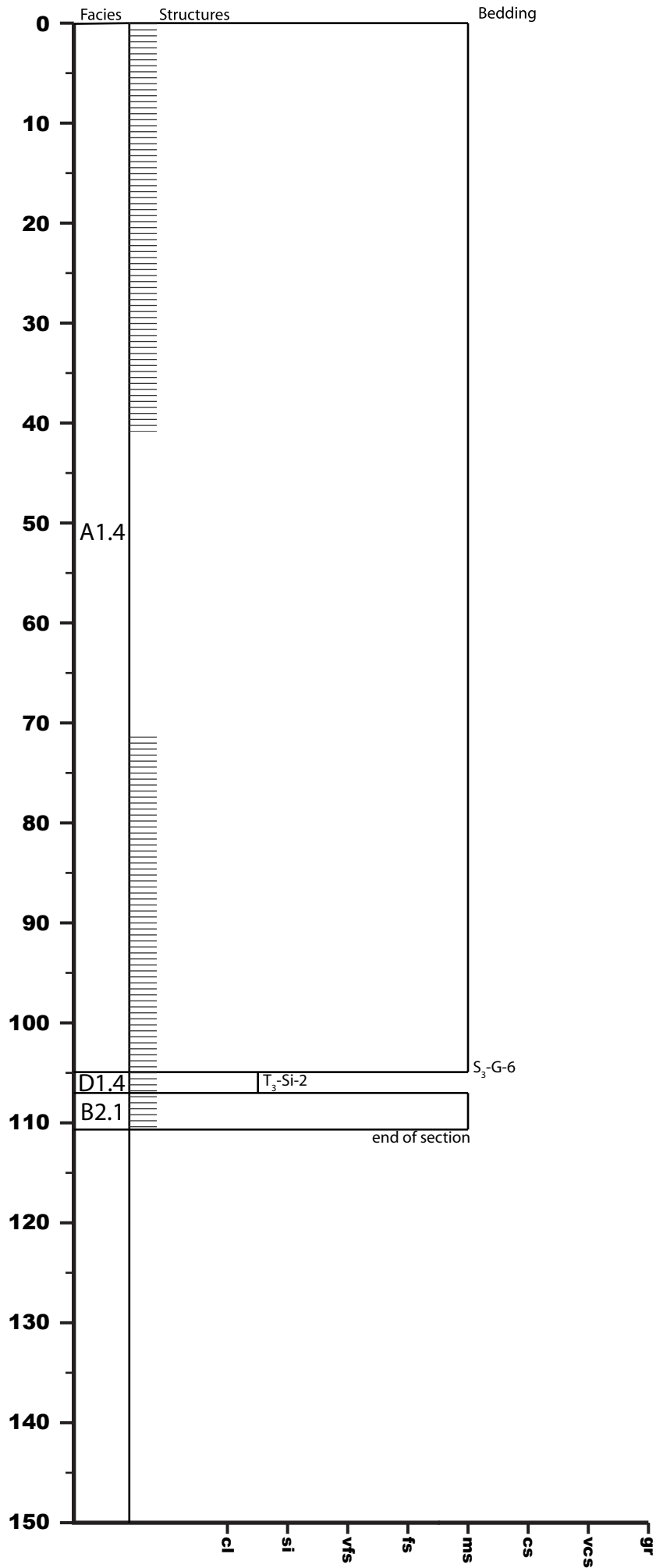

U1438E-15R-7

981.75 - 982.59 mbsf

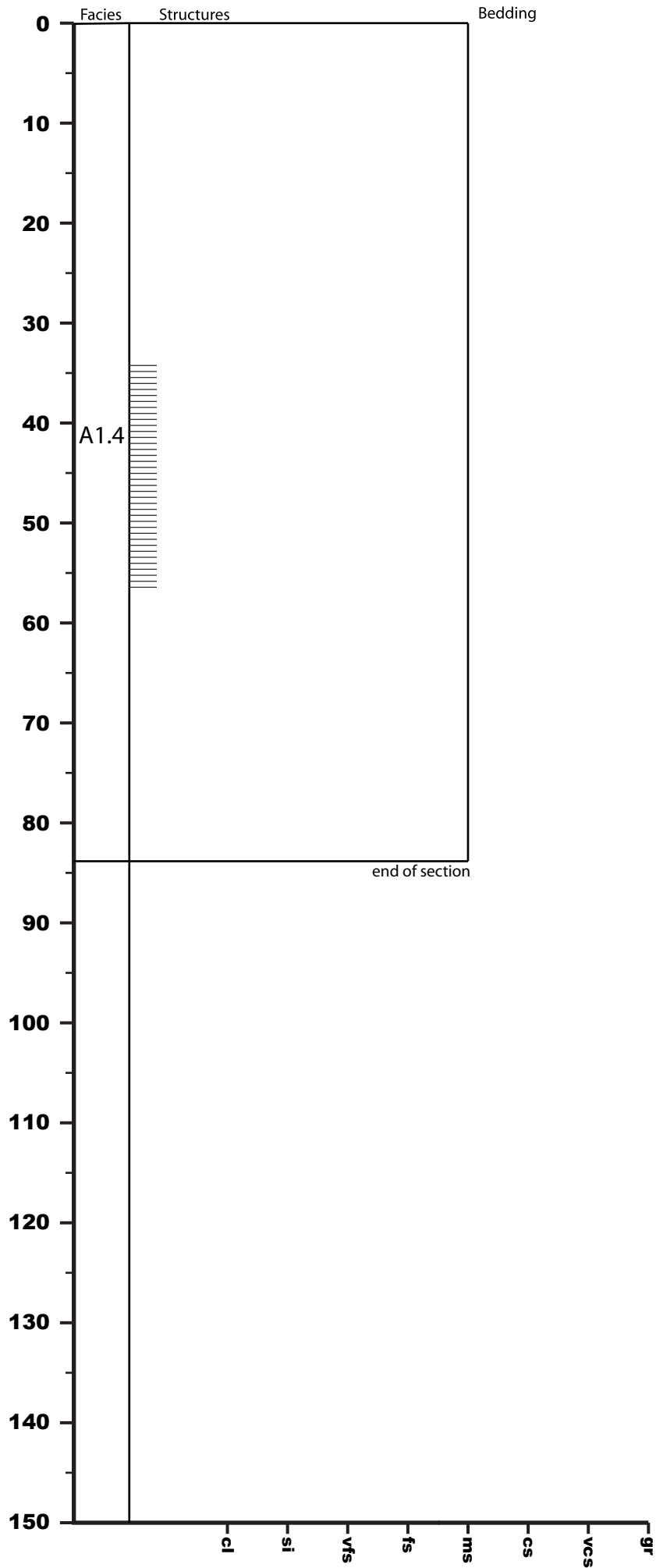

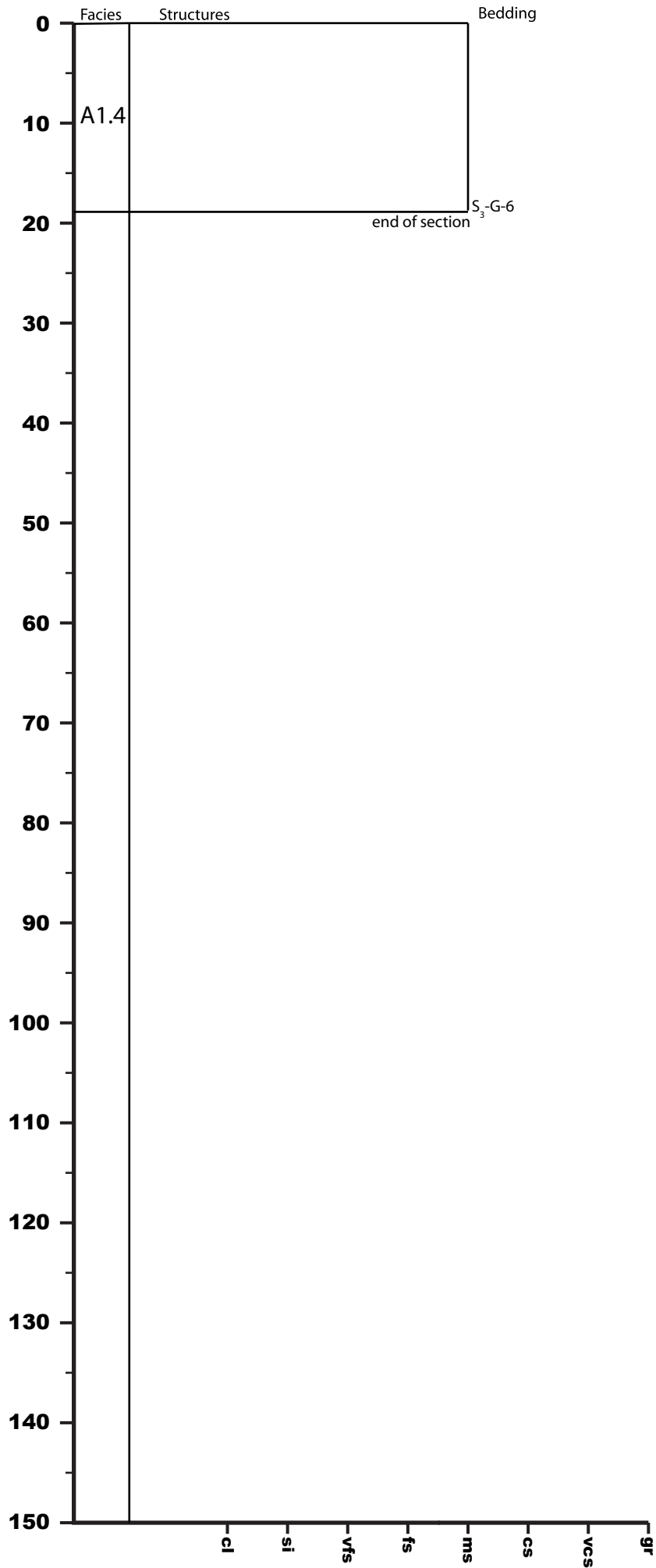

U1438E-16R-1

983.5 - 985 mbsf

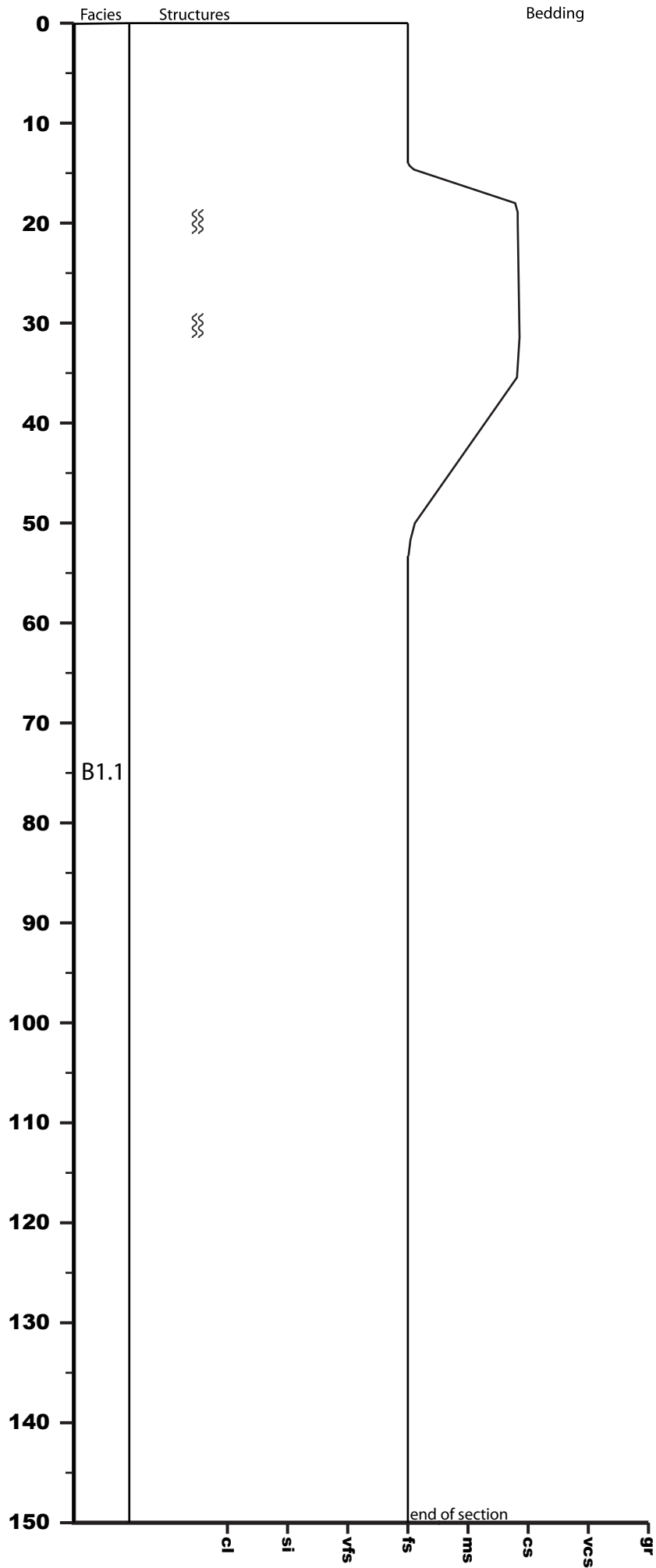



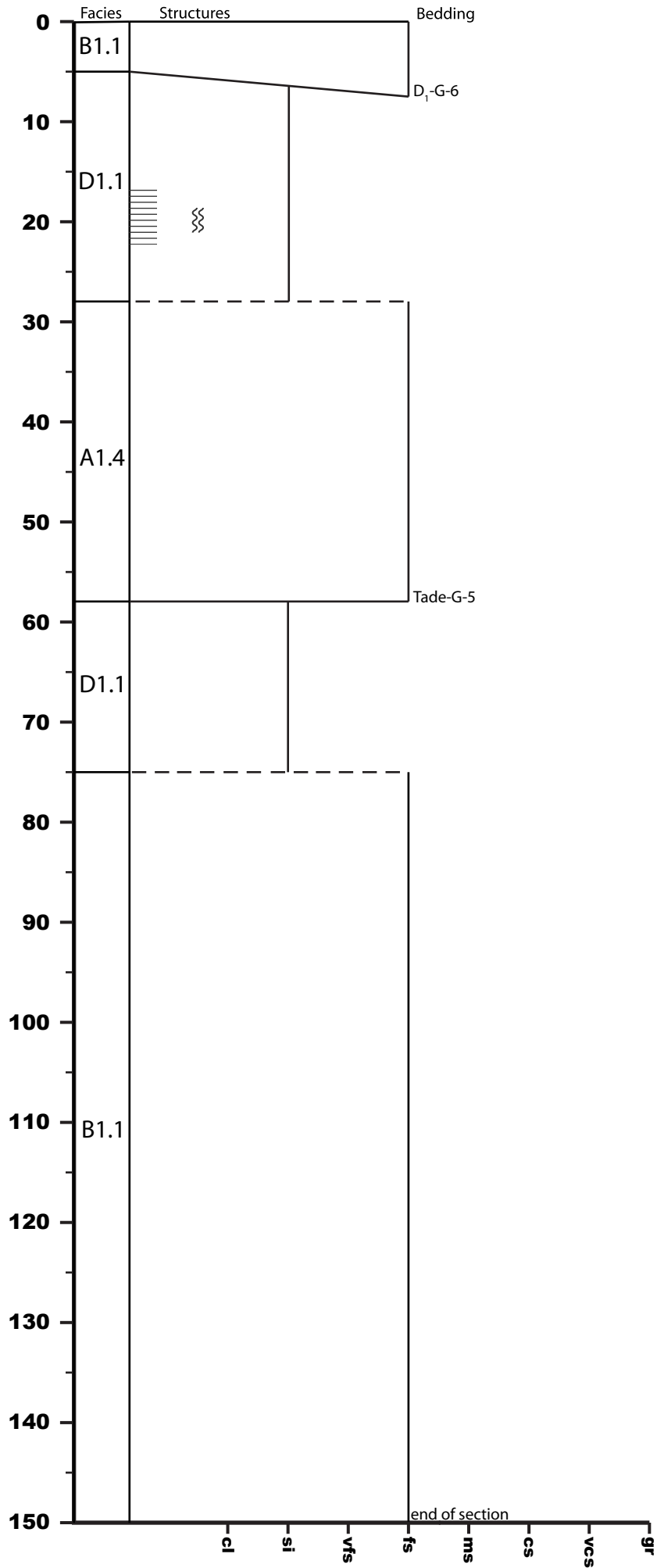

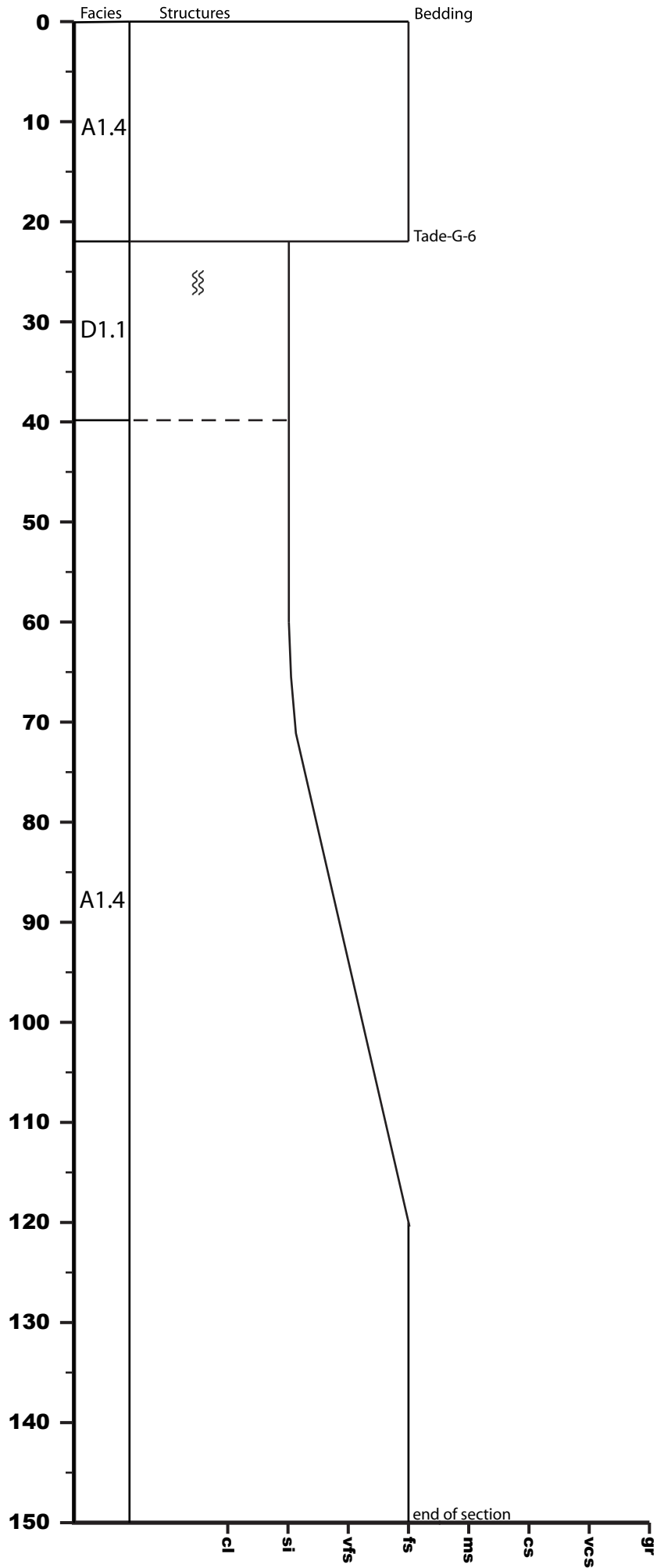

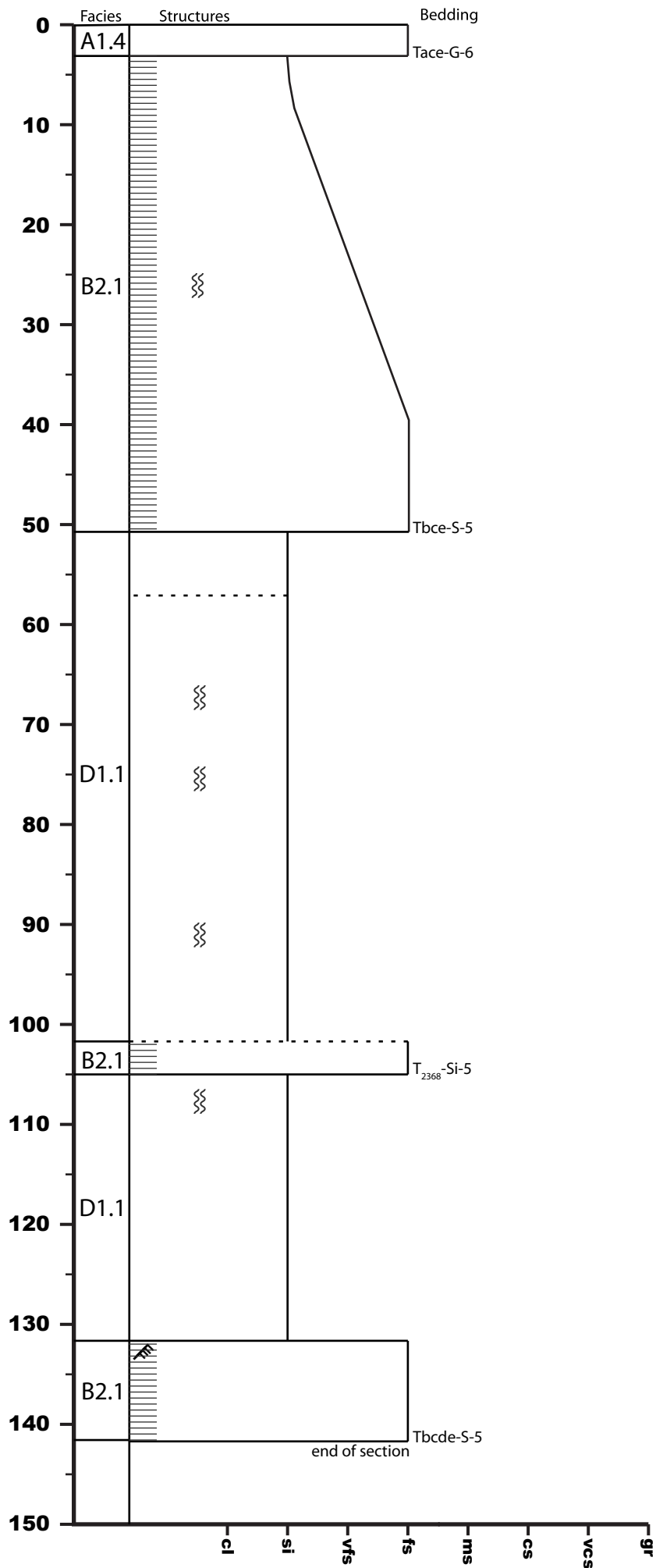

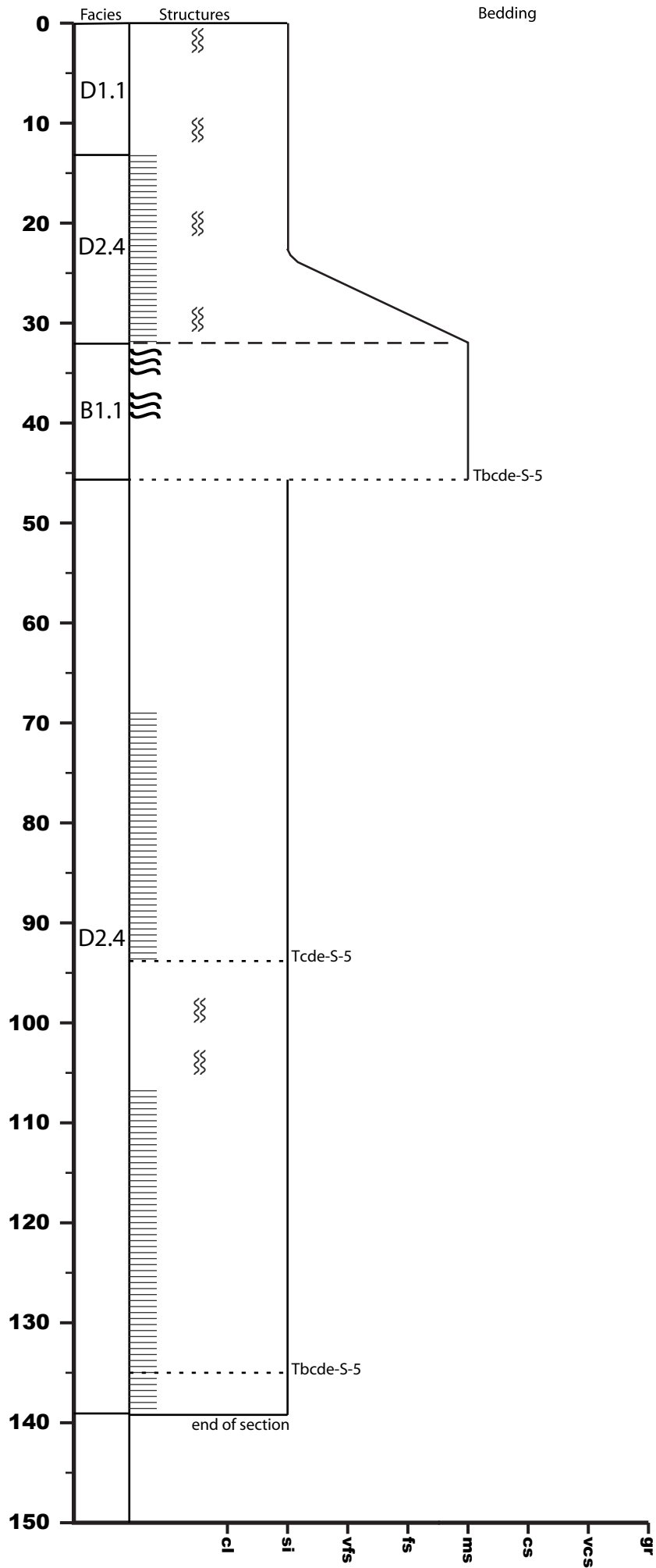

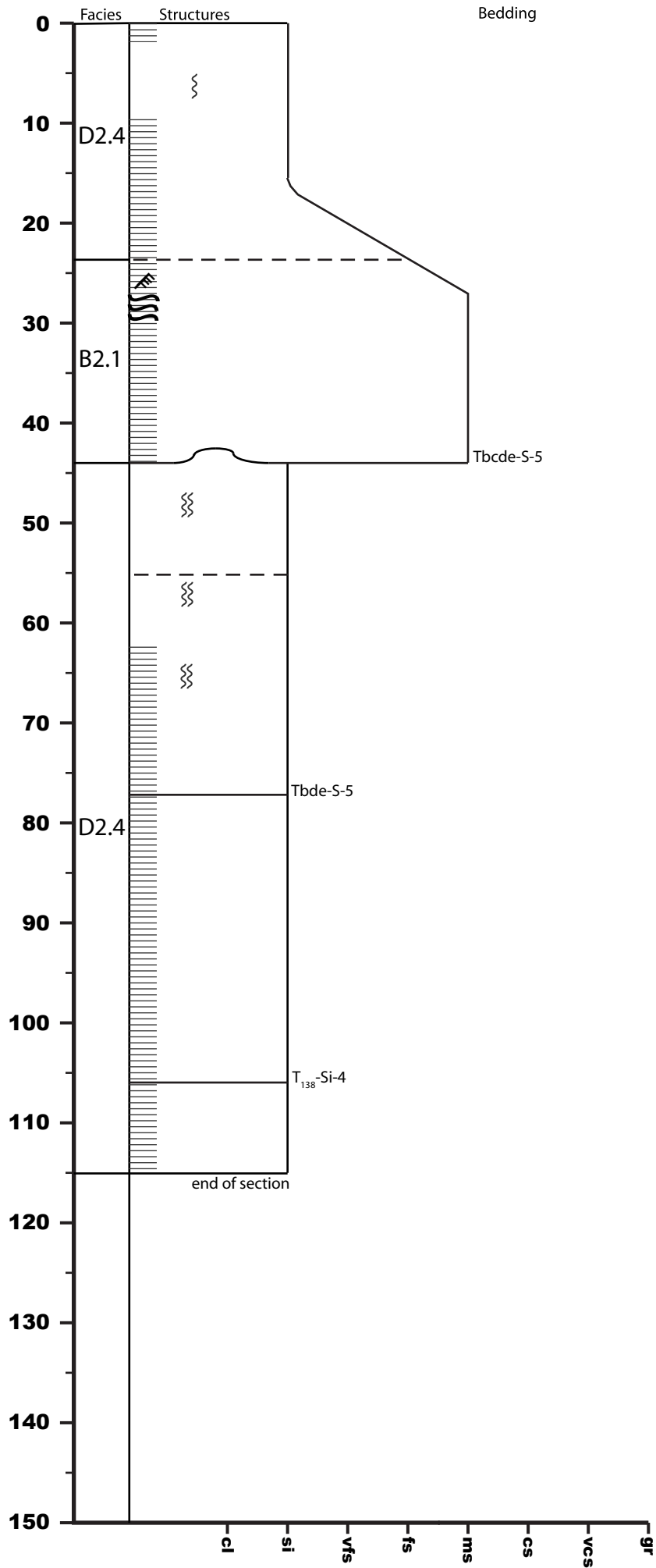

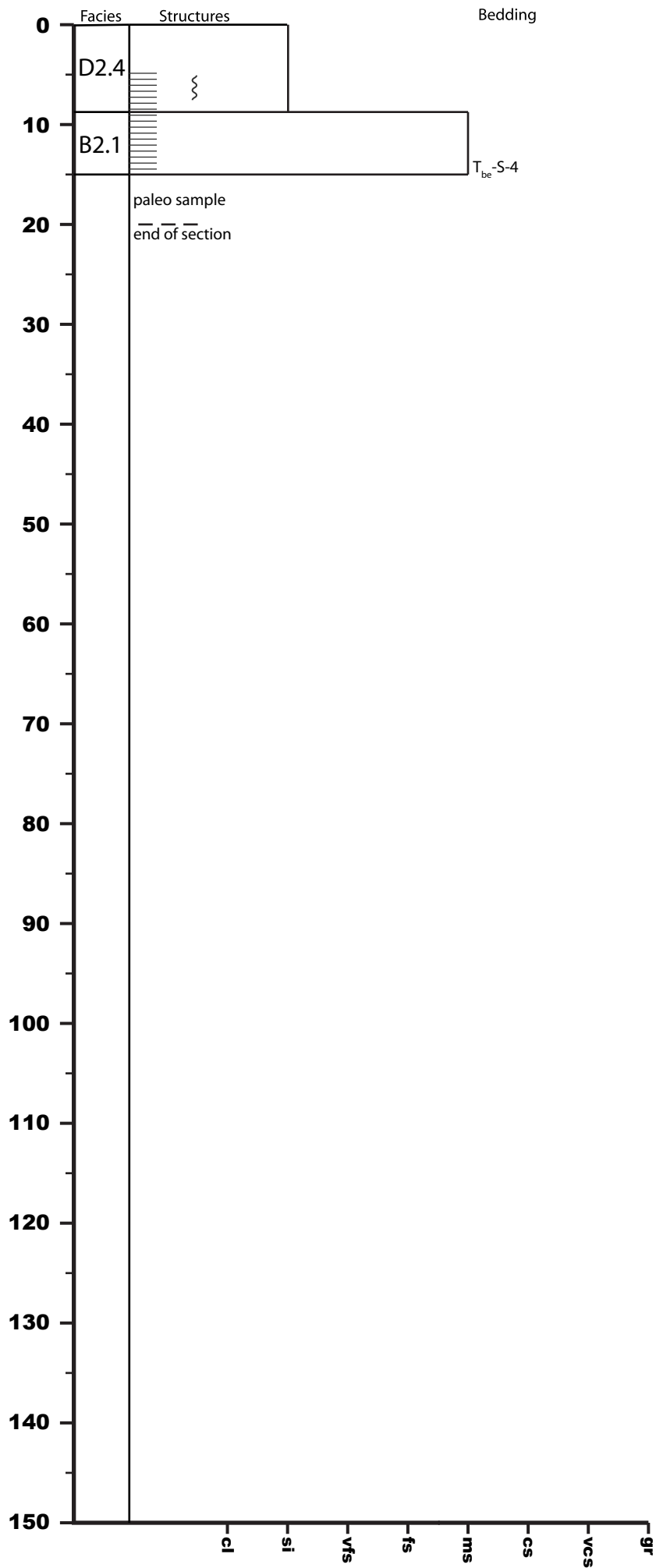

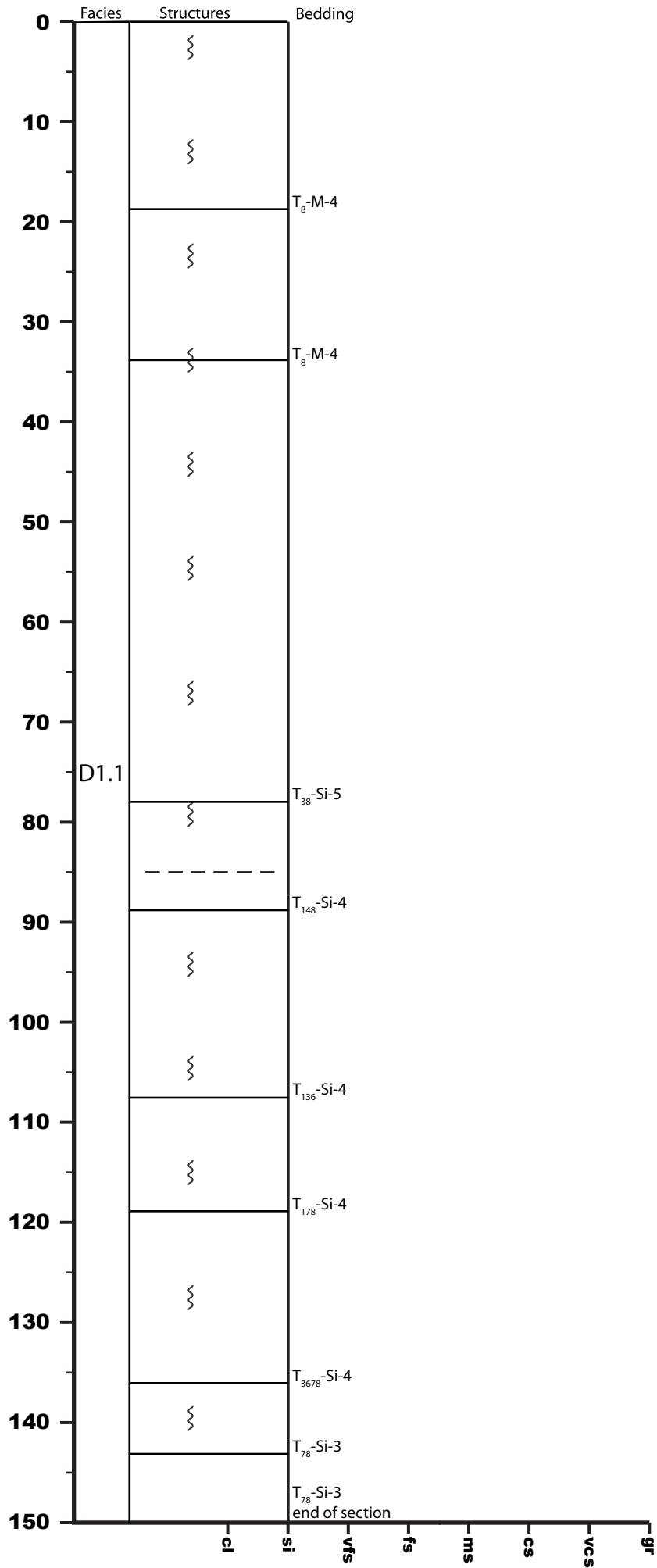

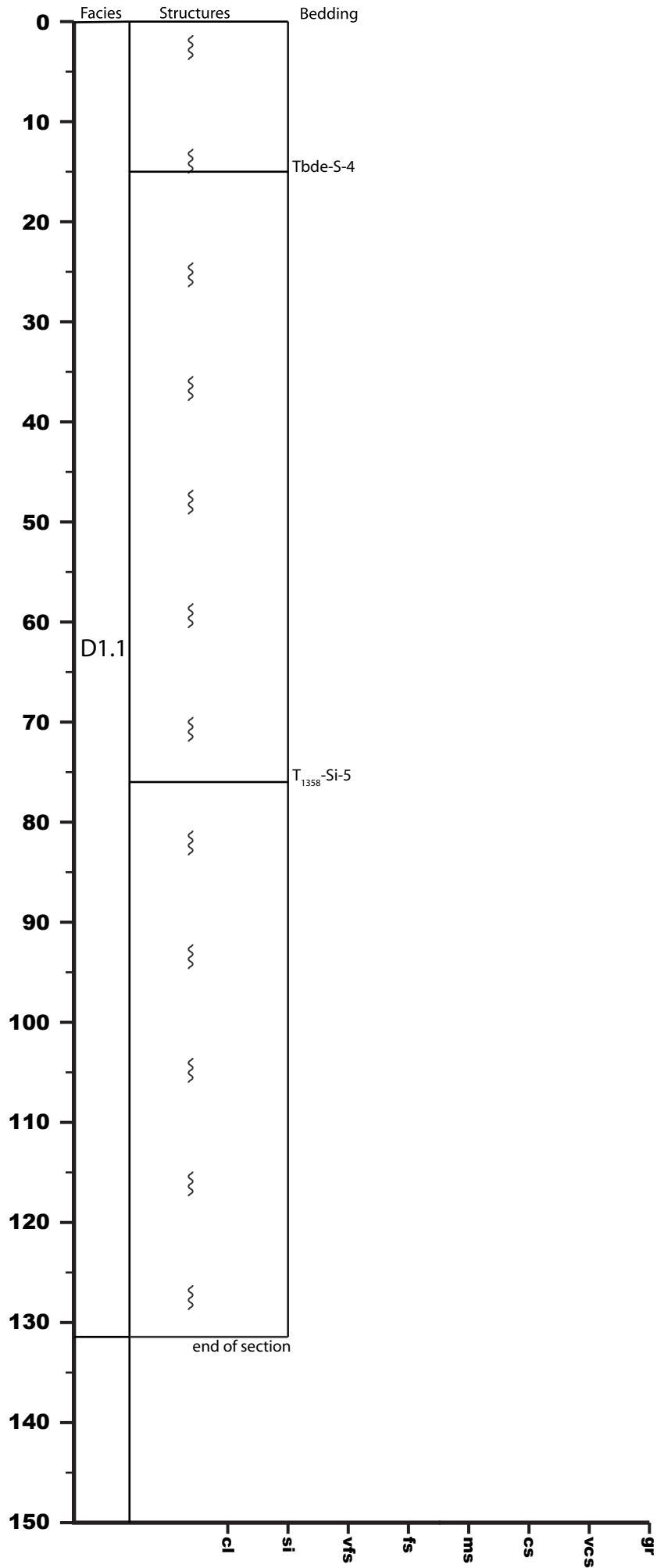



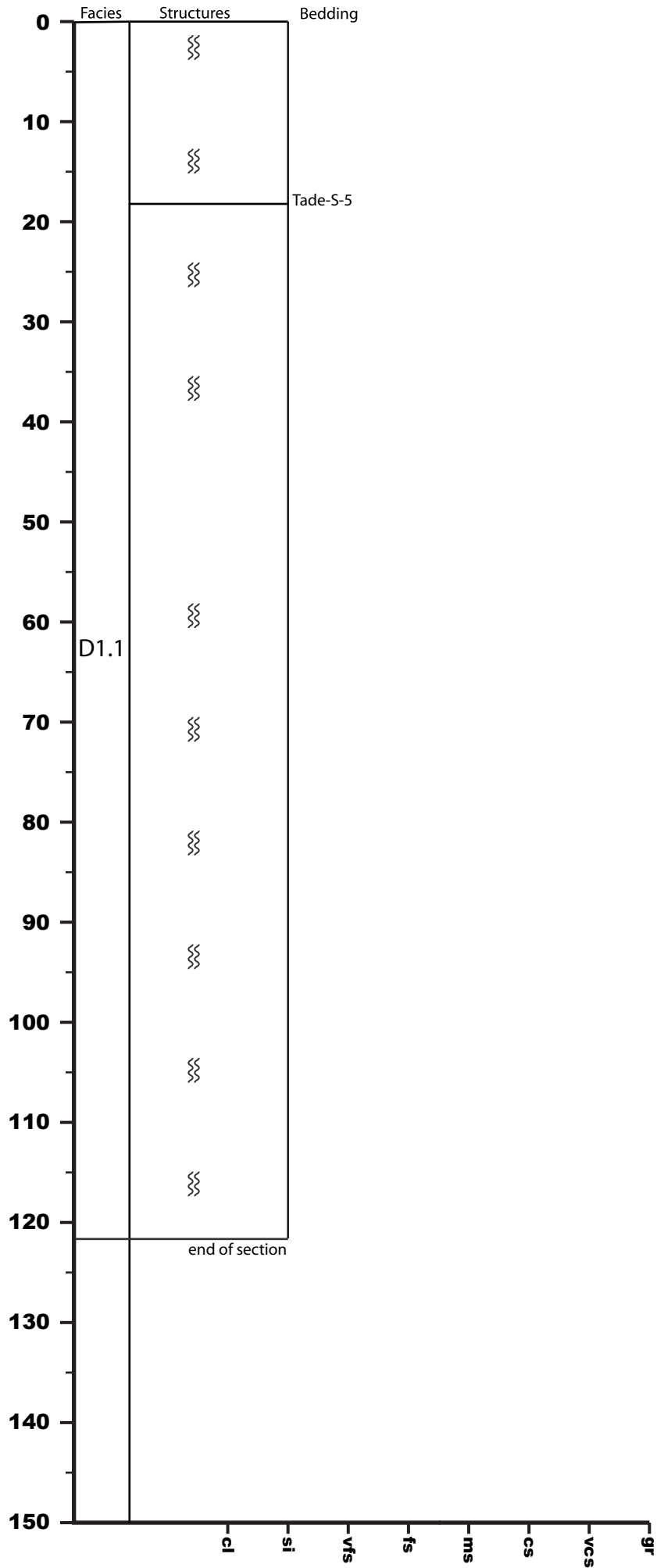

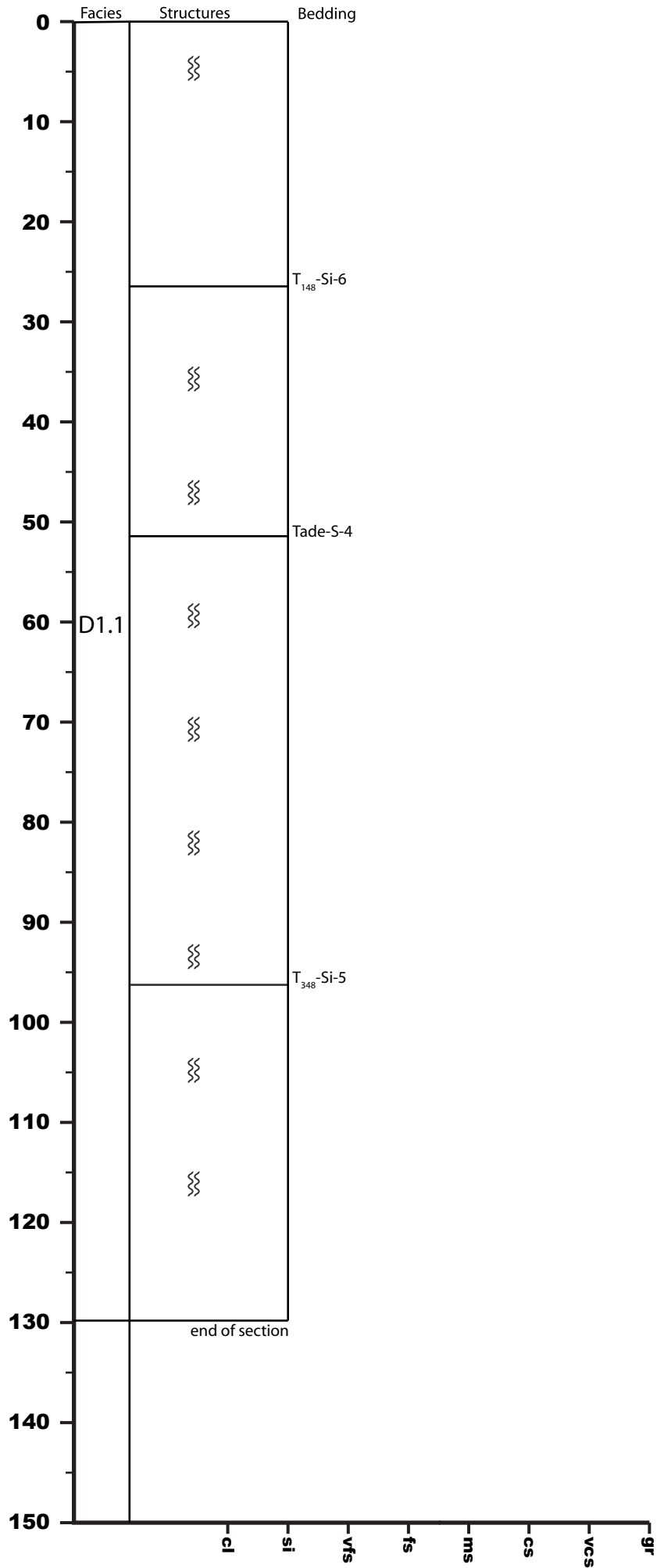

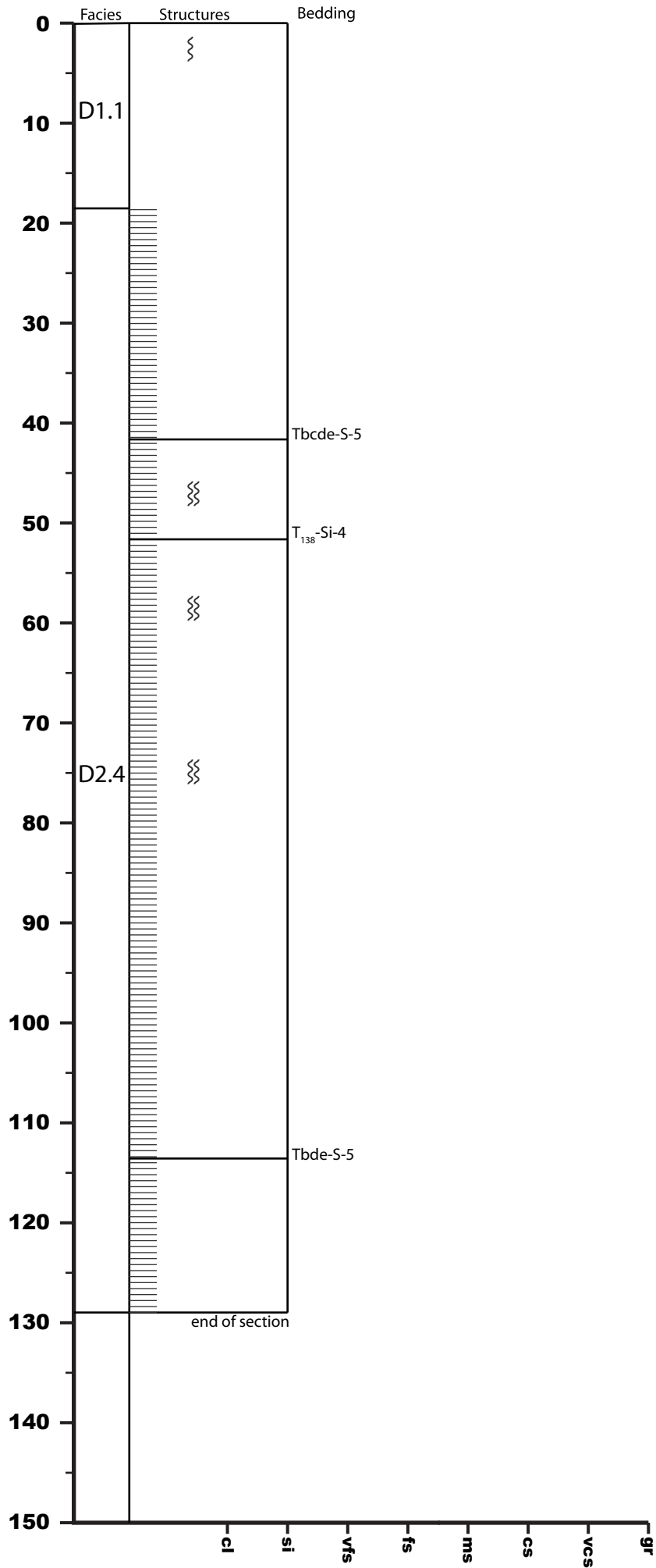

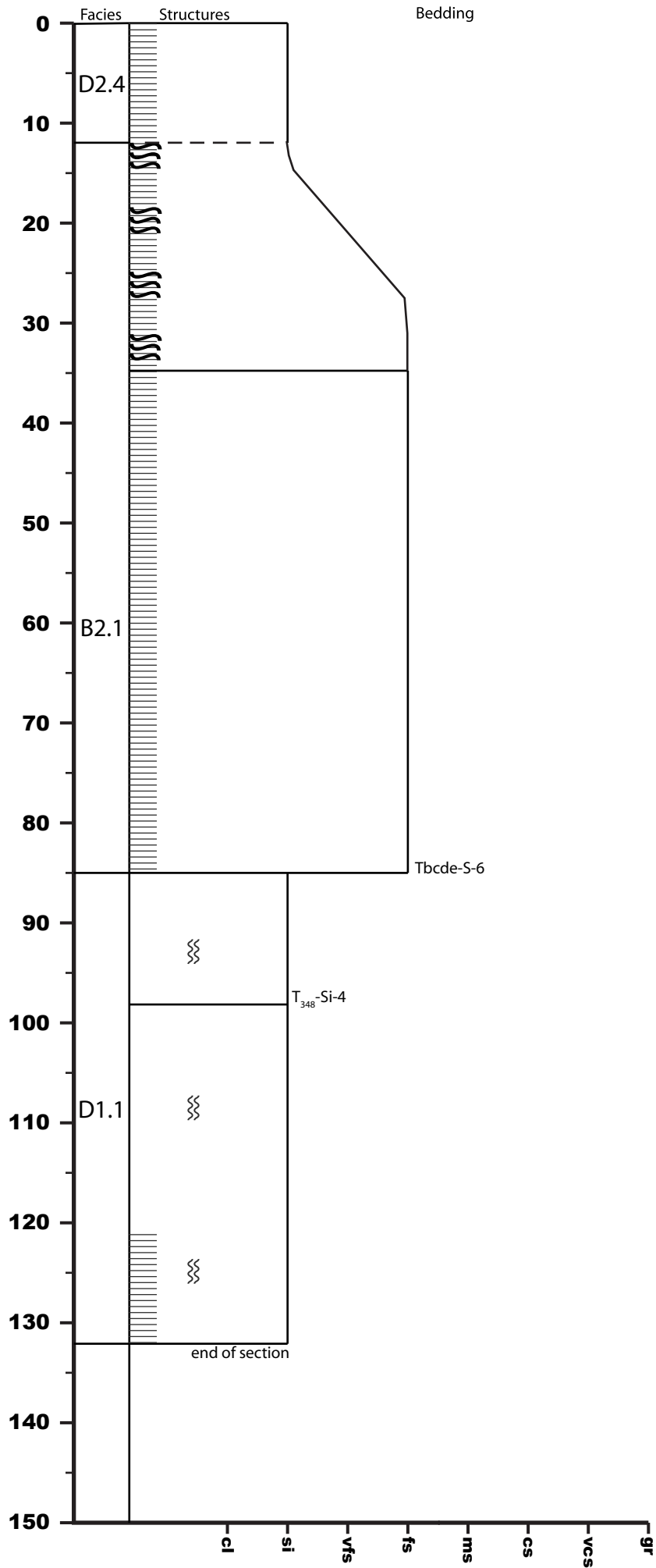

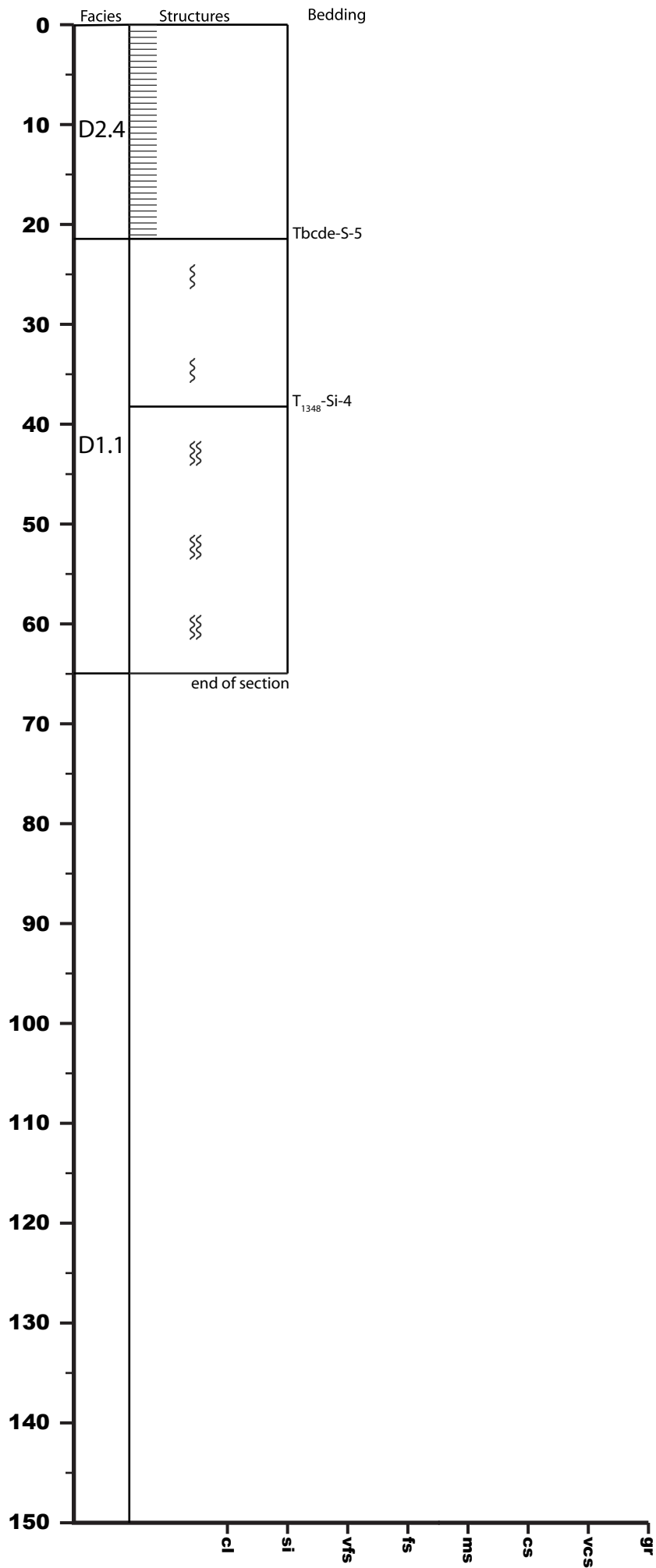

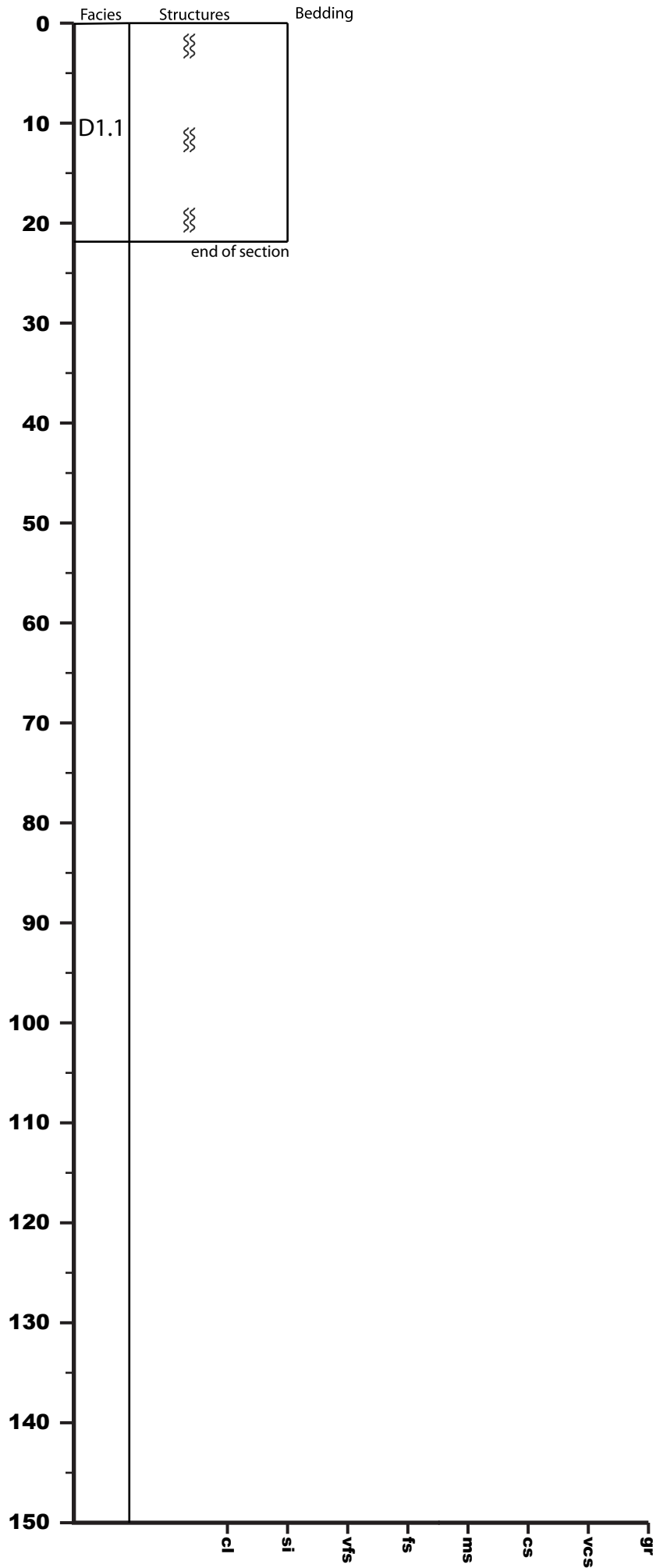

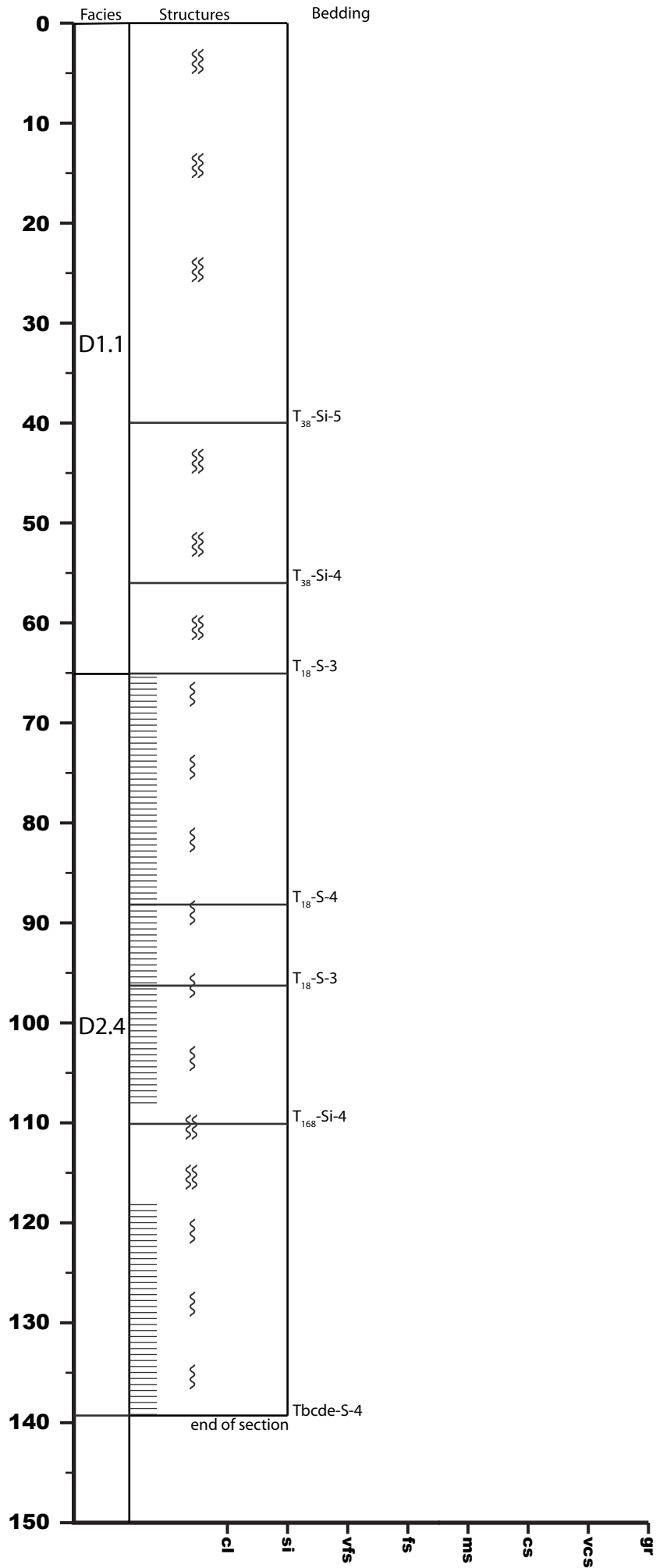

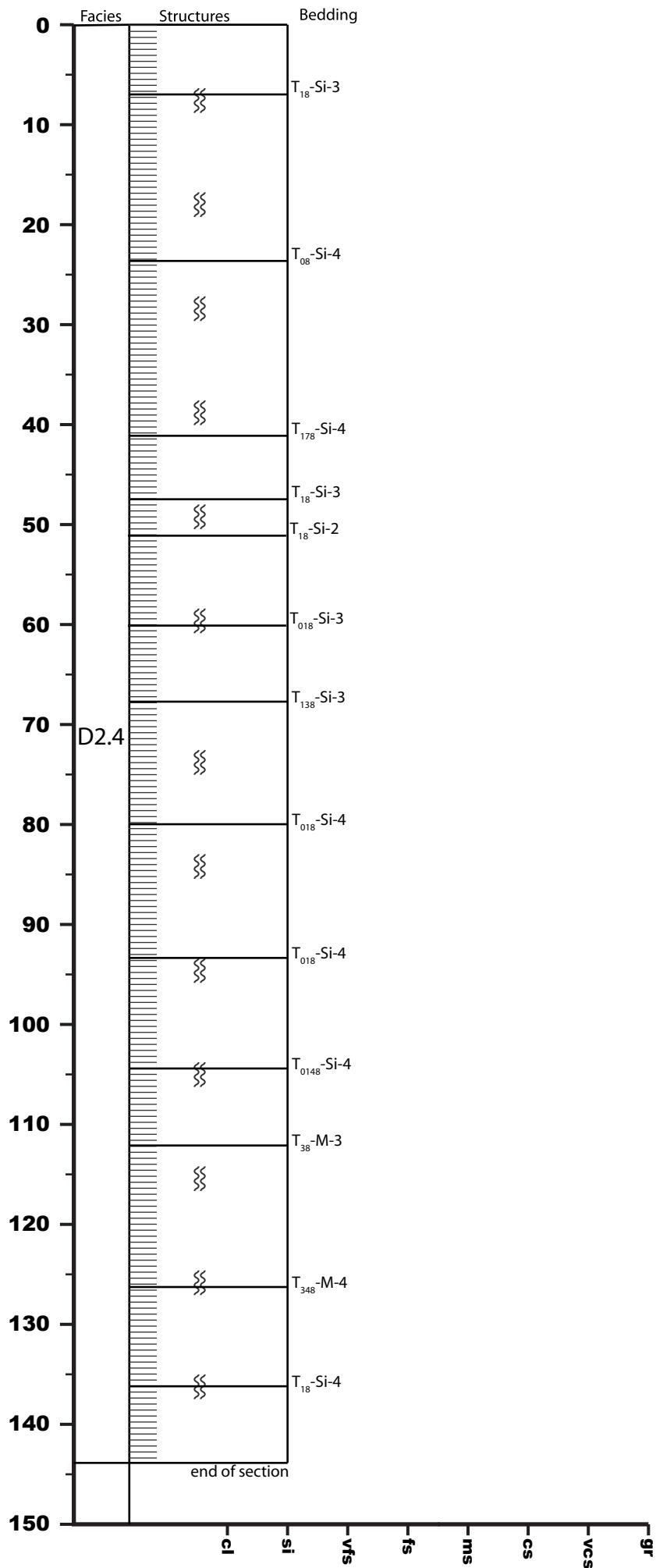



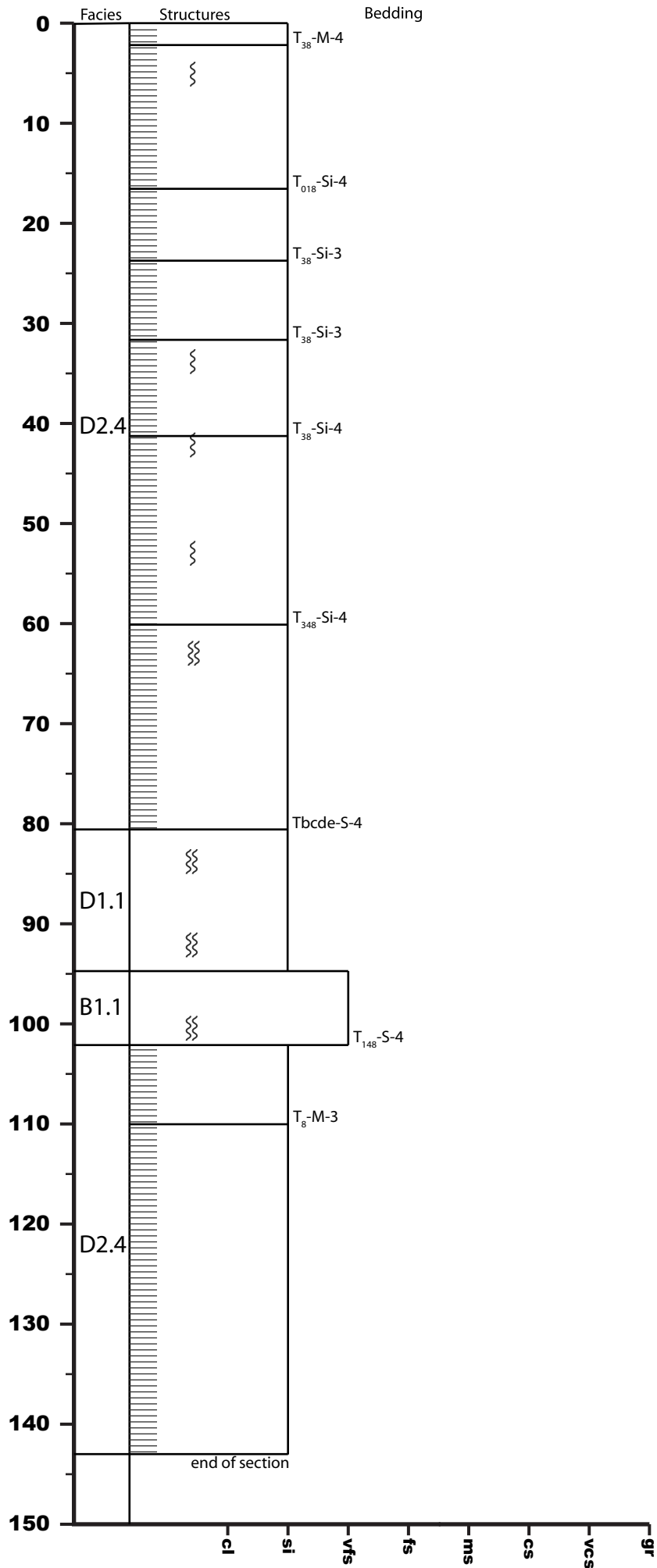

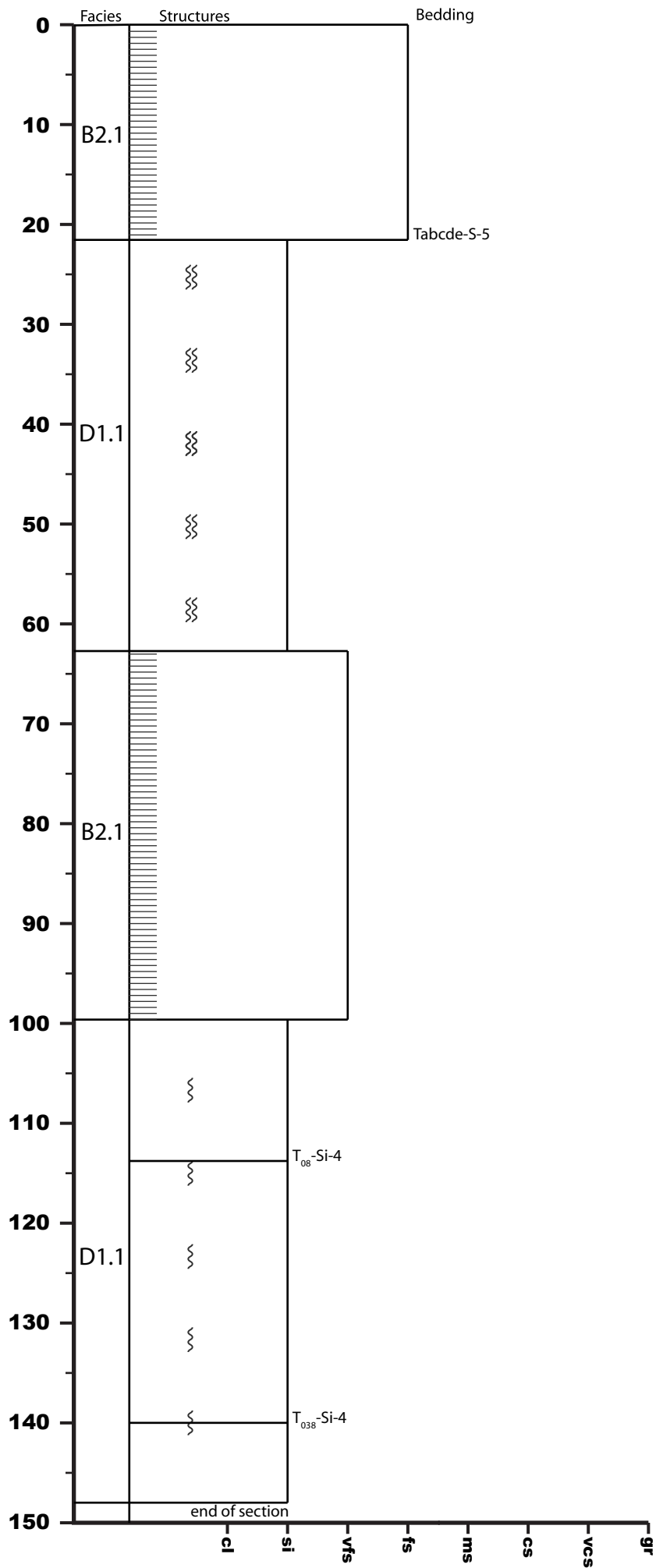

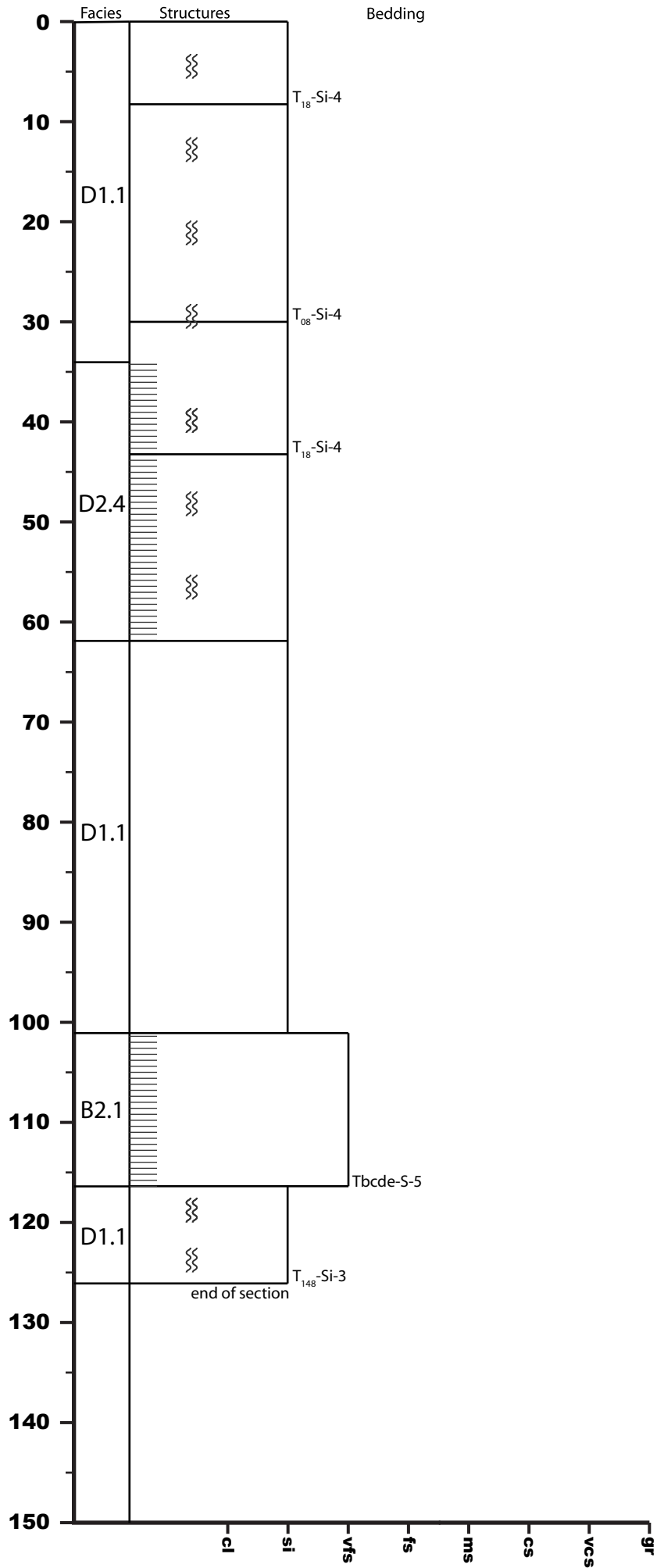

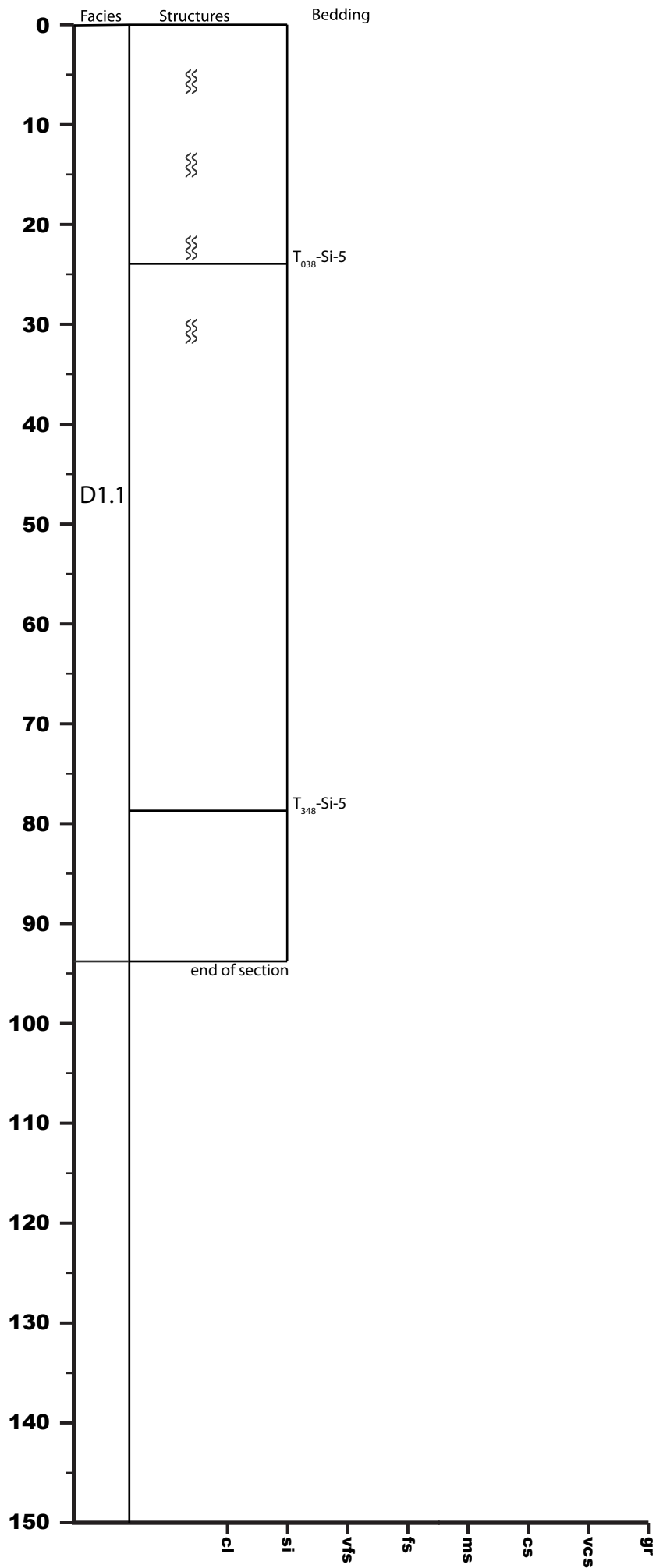

U1438E-18R-7

1010.86 - 1011.63 mbsf

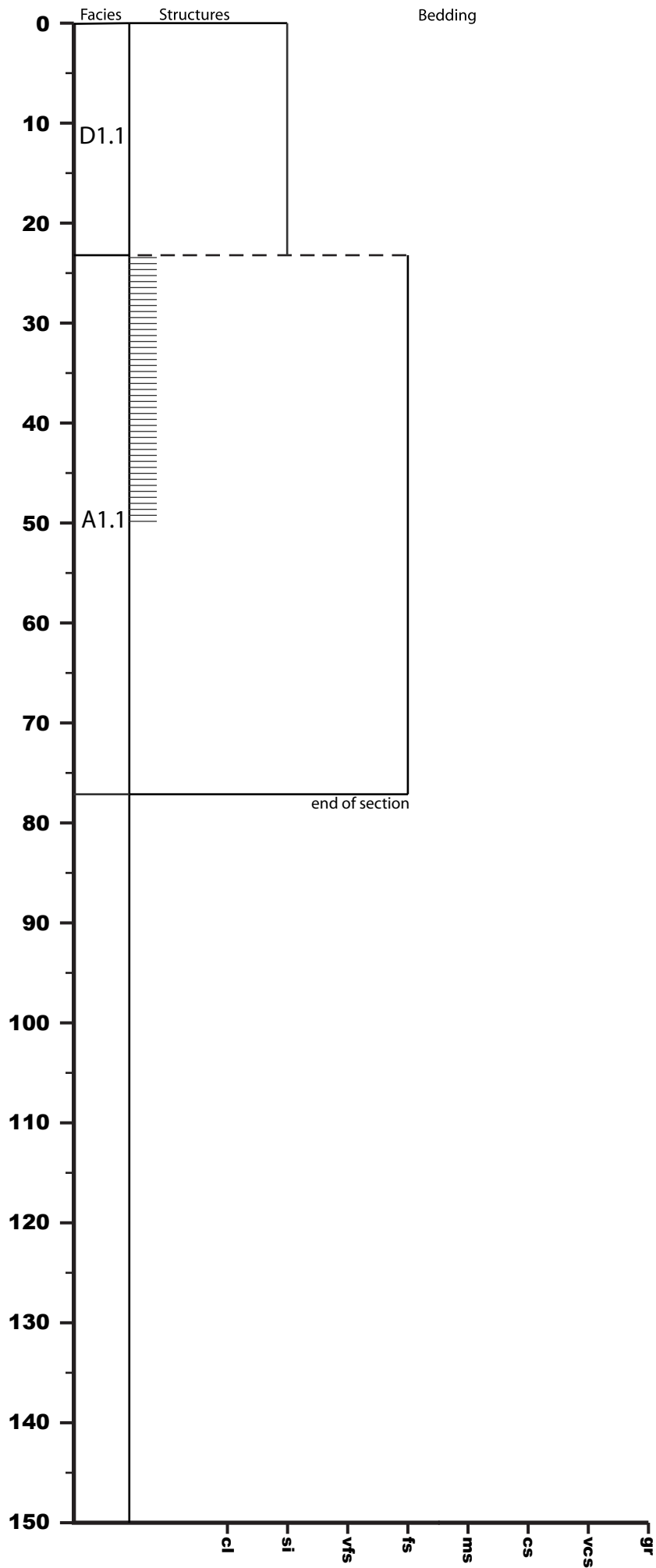

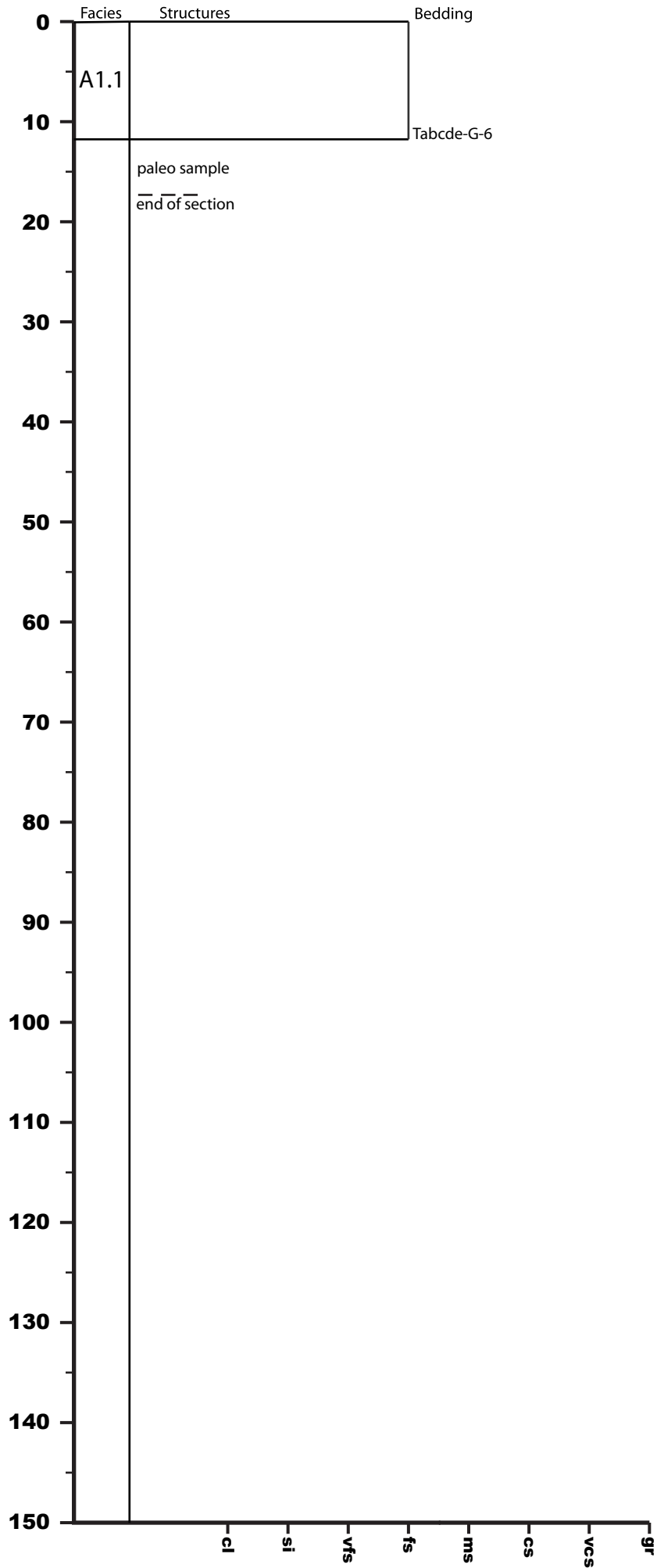

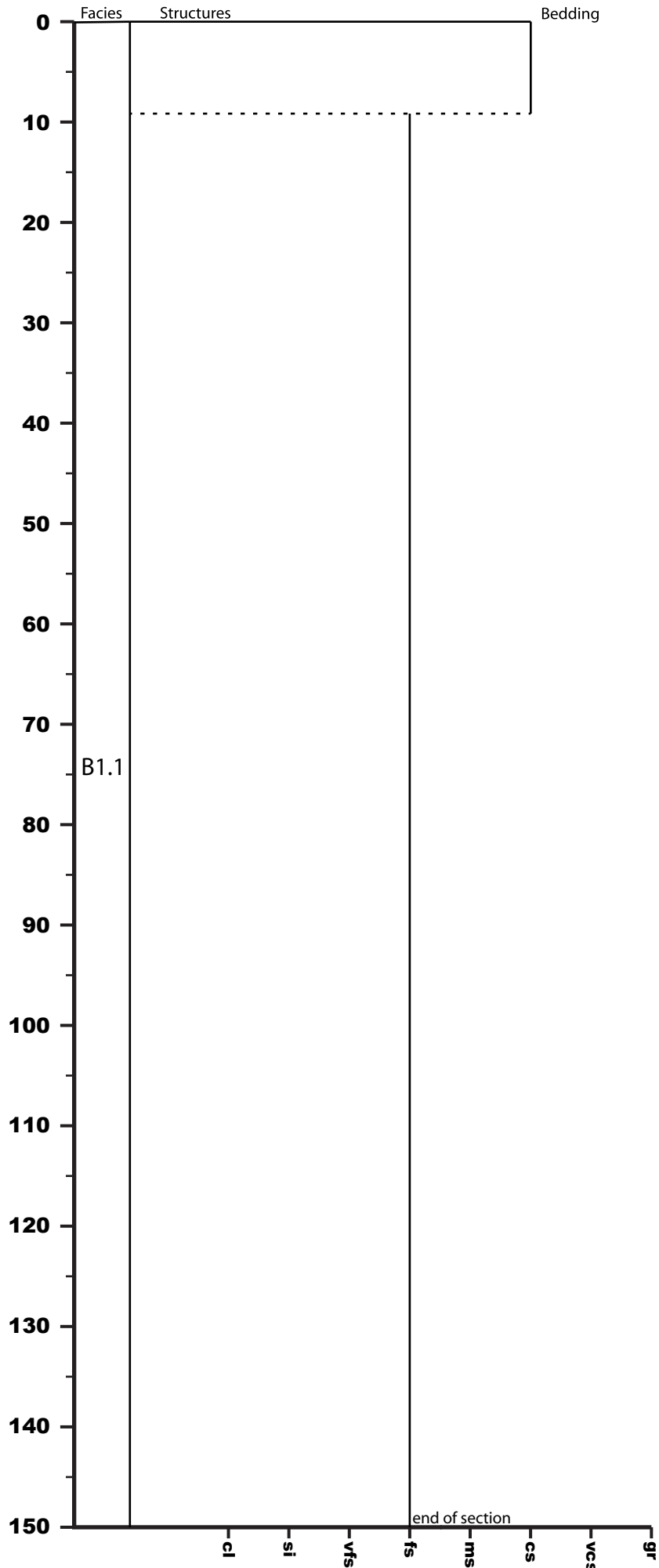

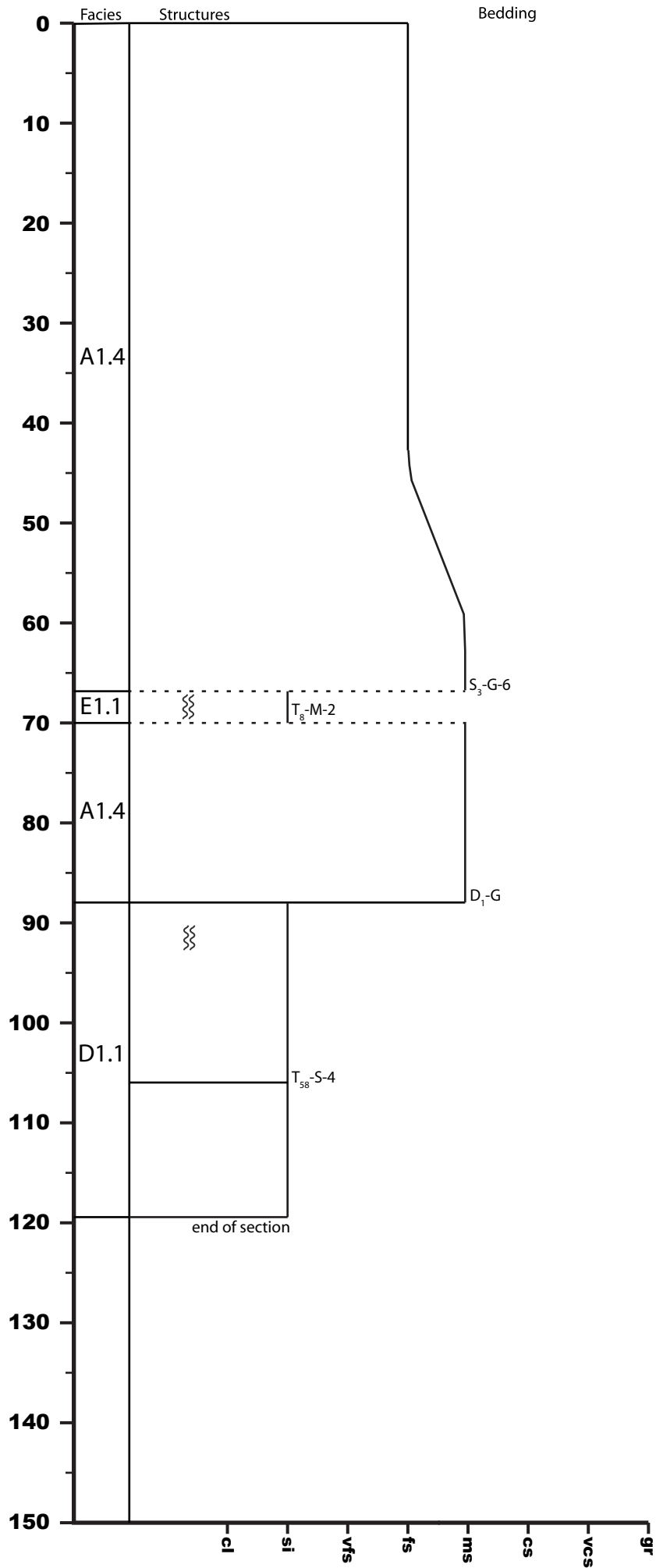



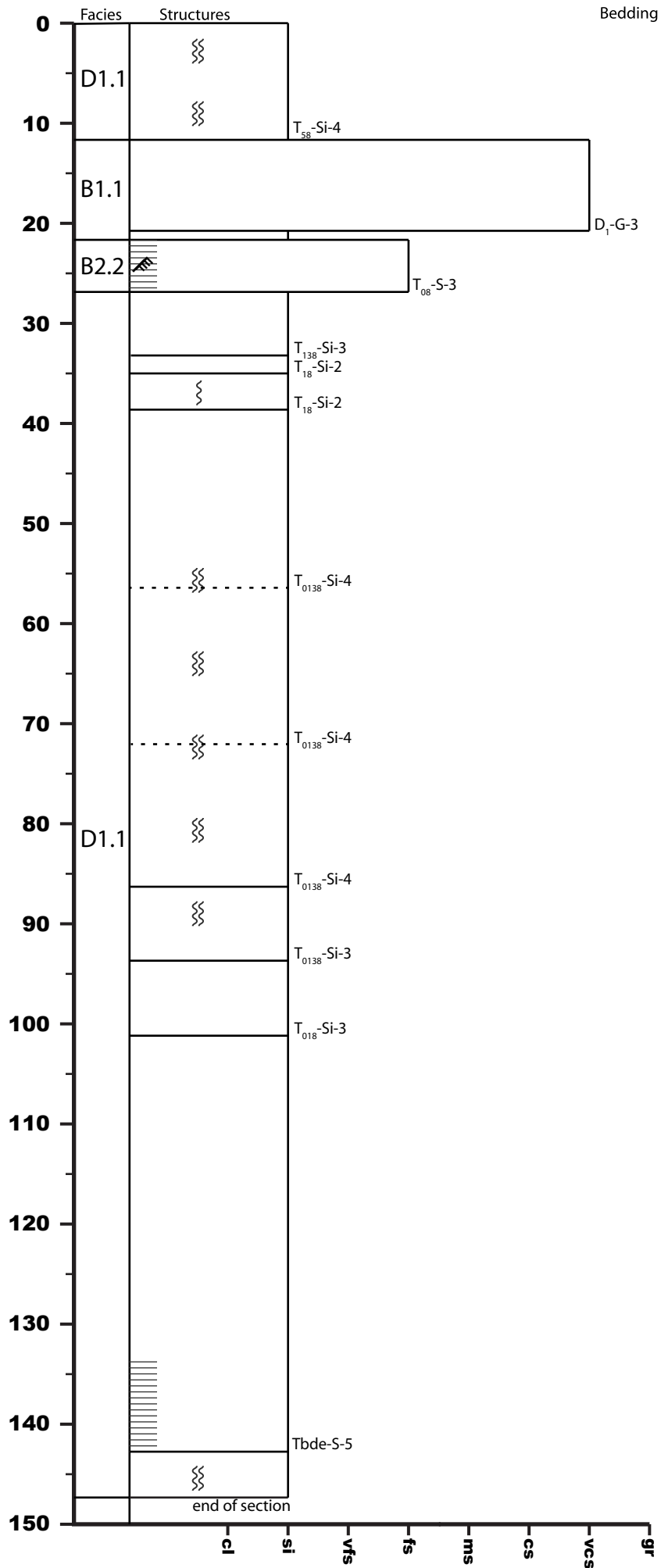

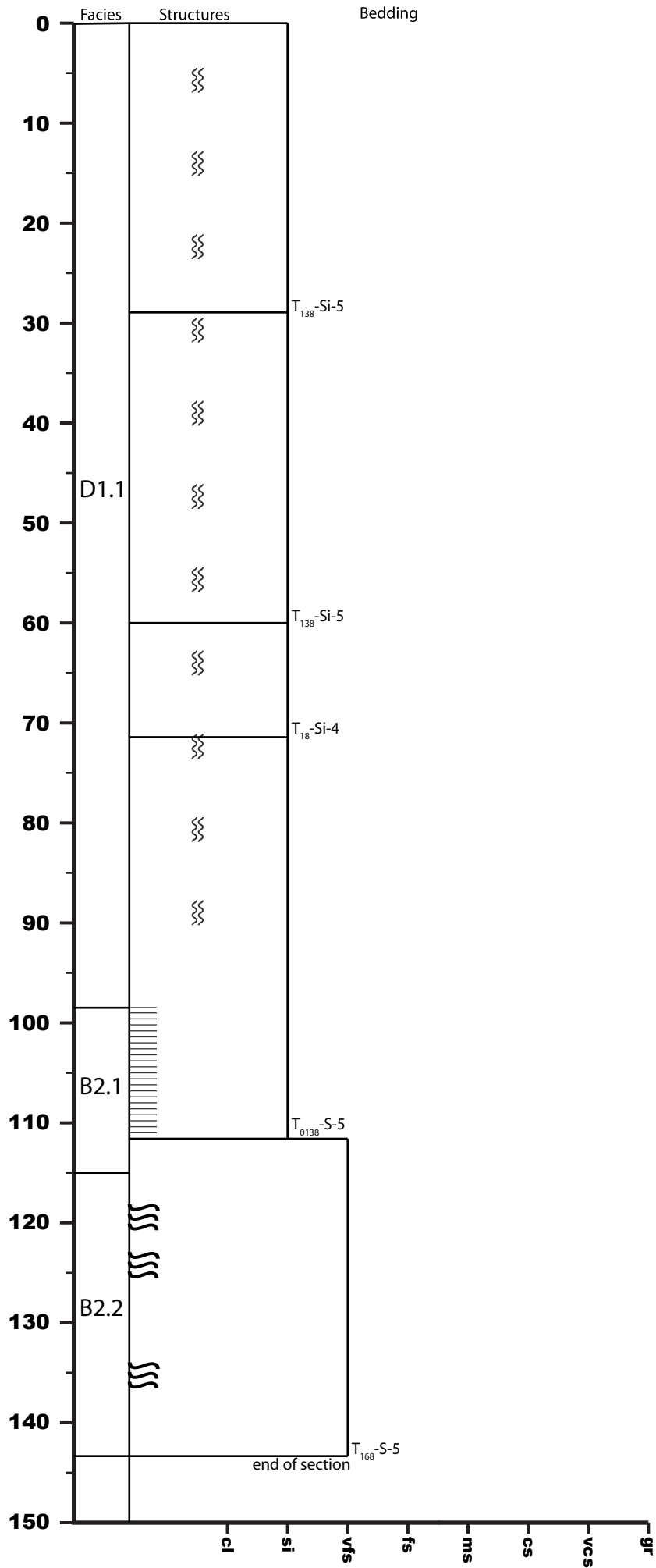

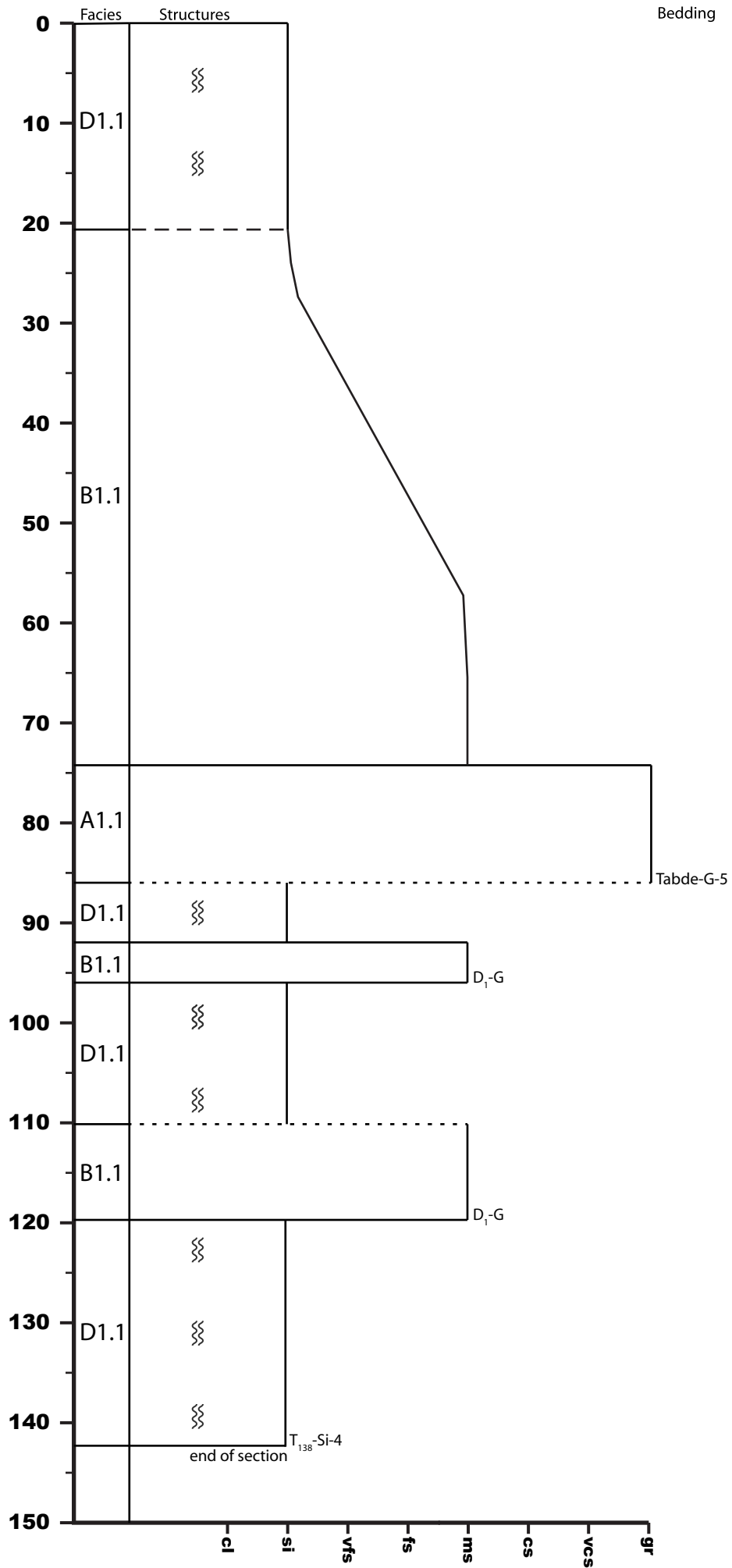

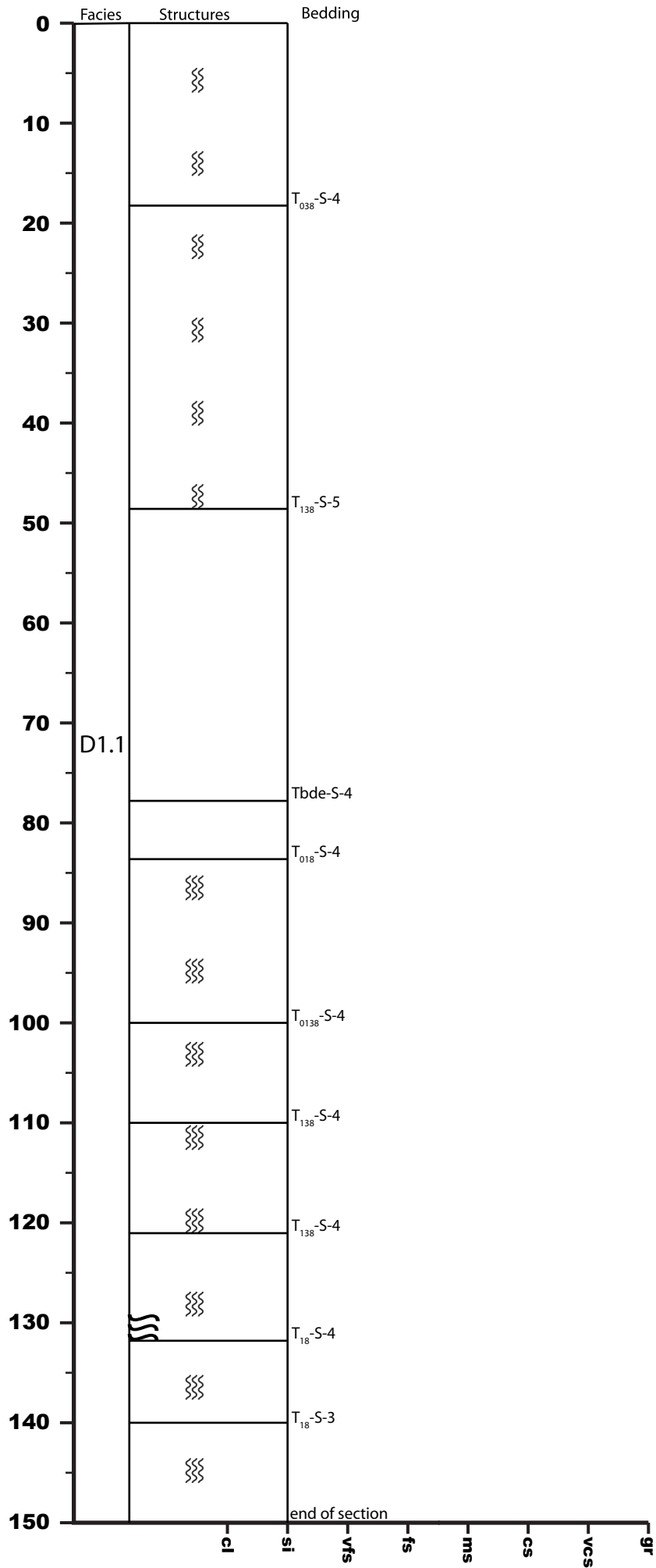

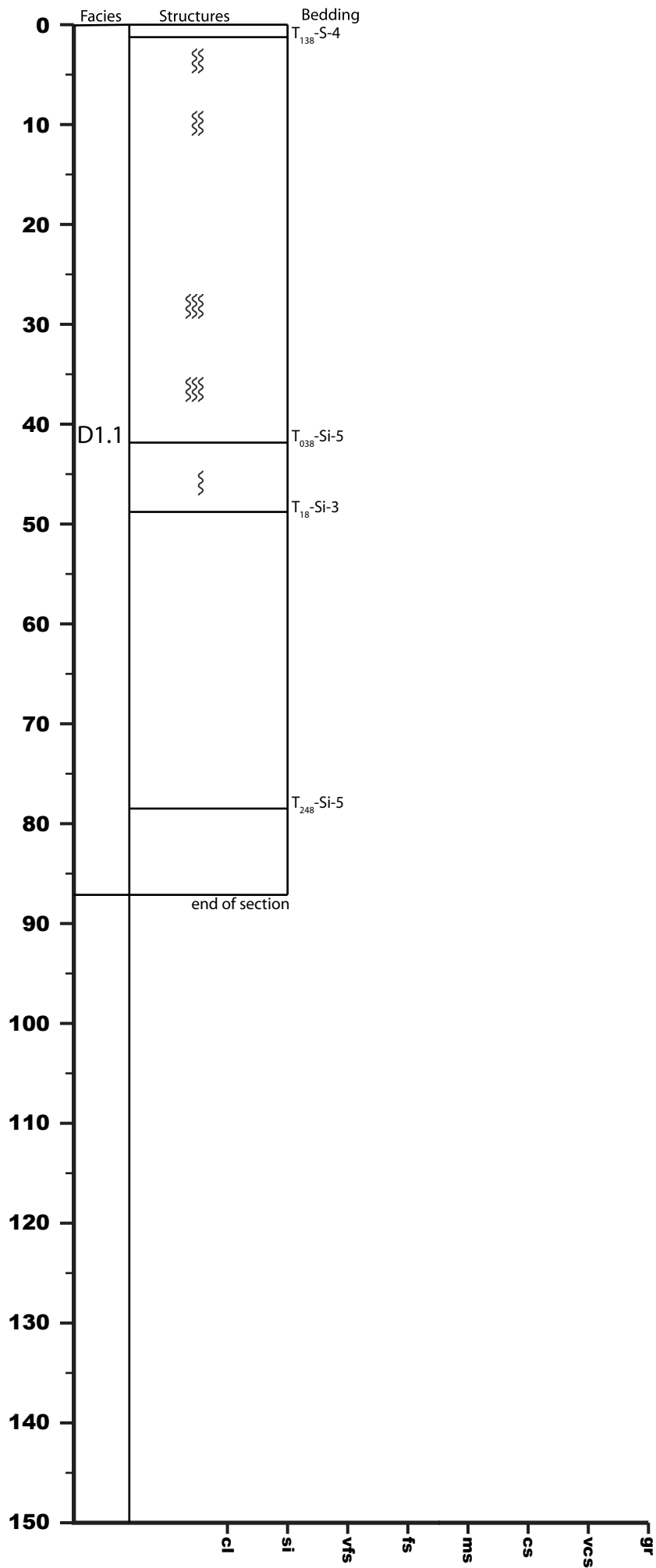

U1438E-19R-CC

1021.99 - 1022.07 mbsf

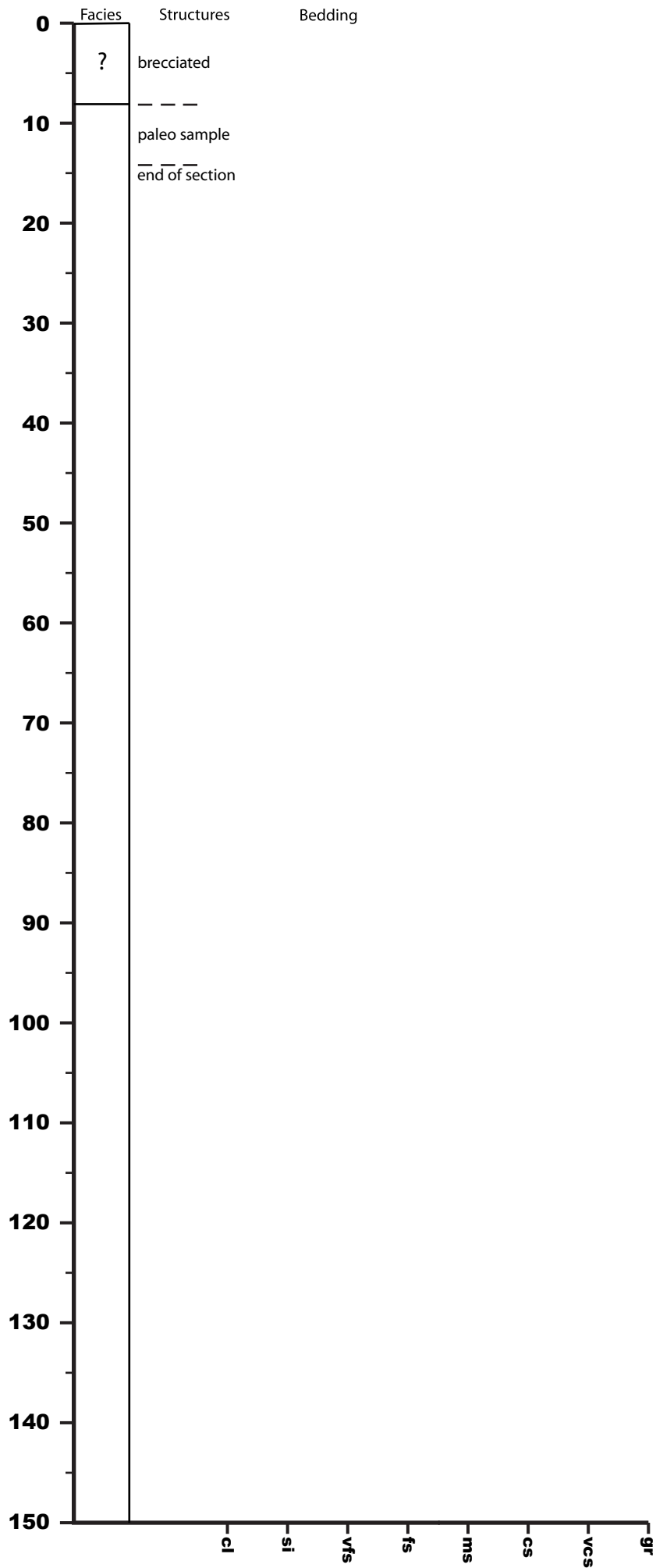

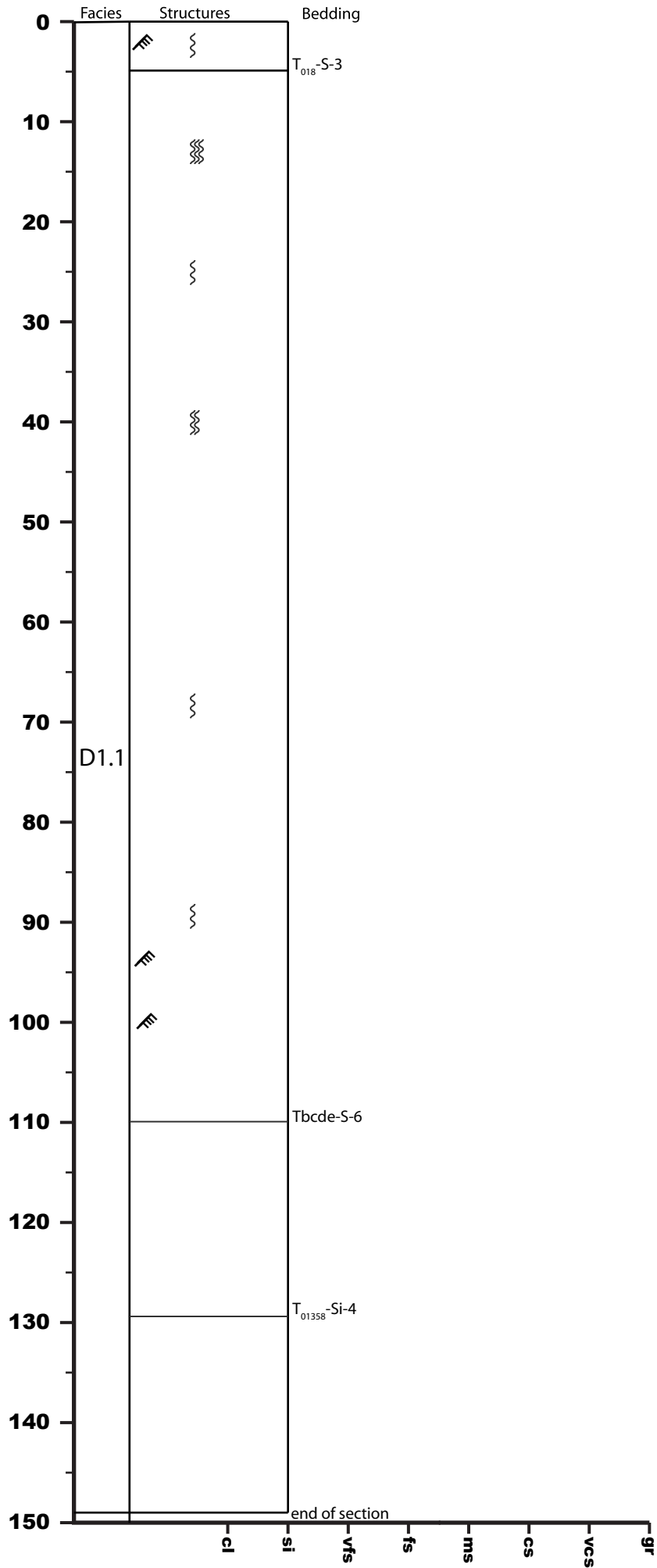

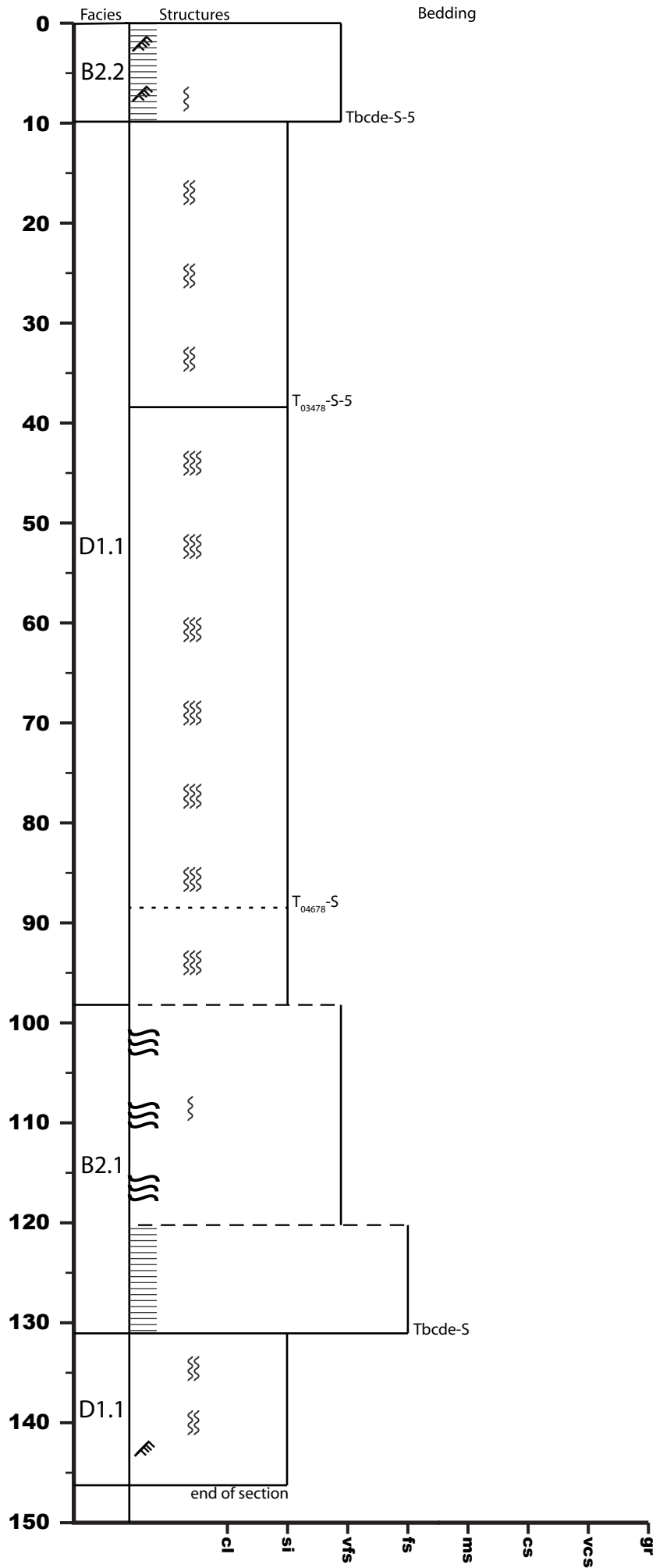



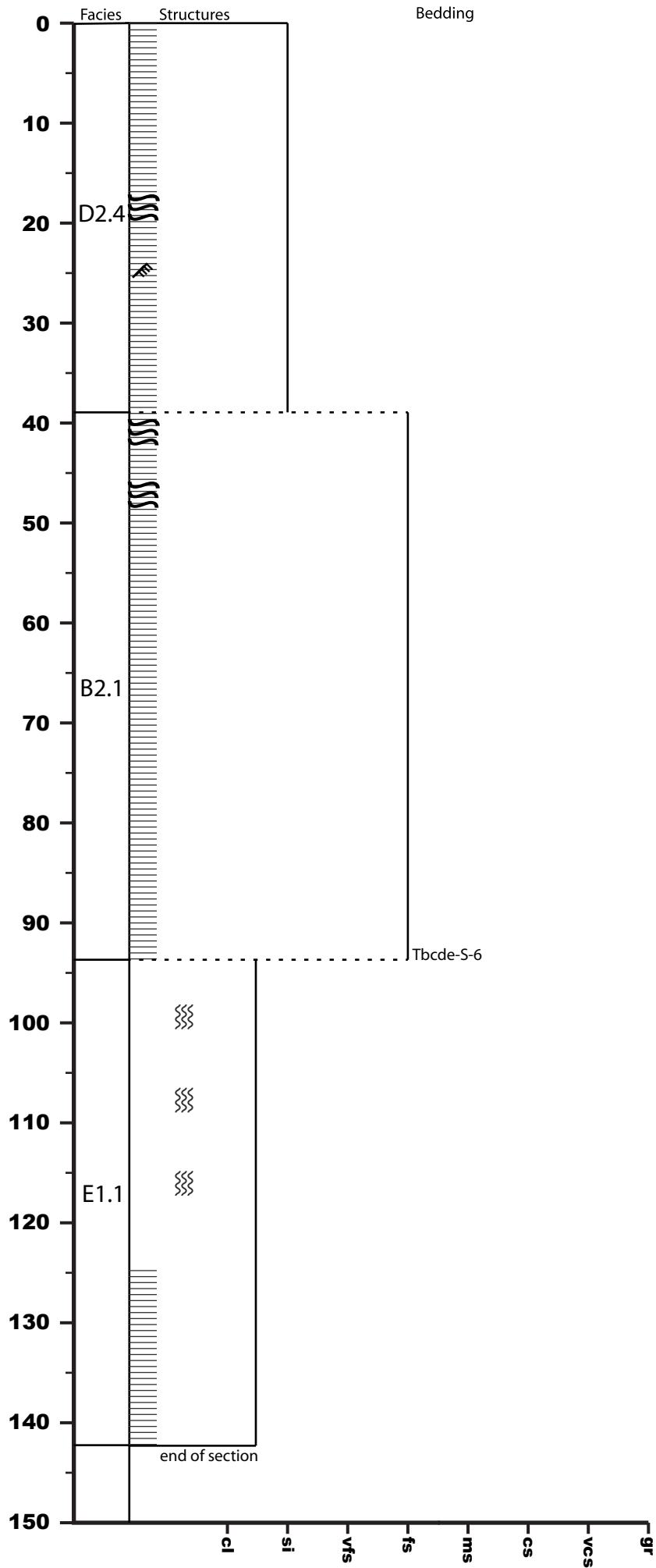

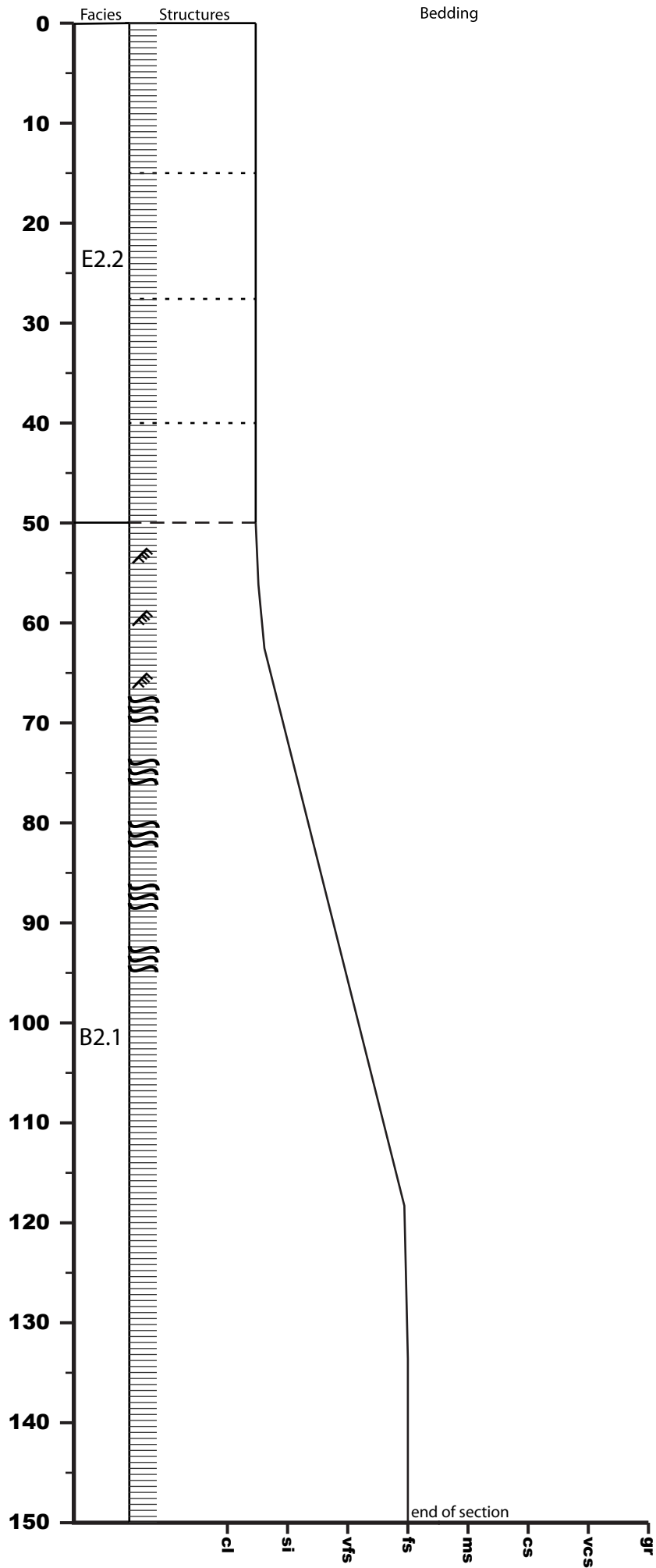

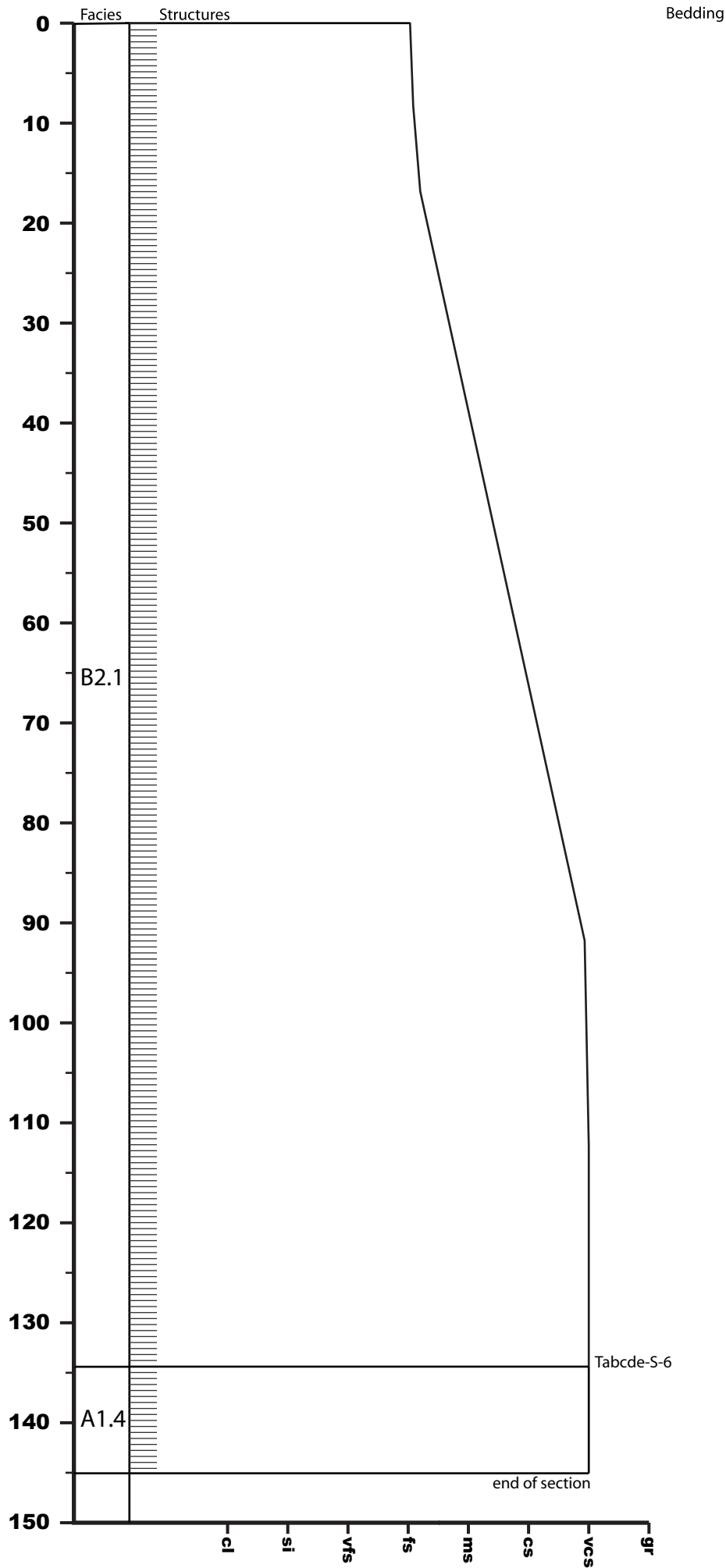

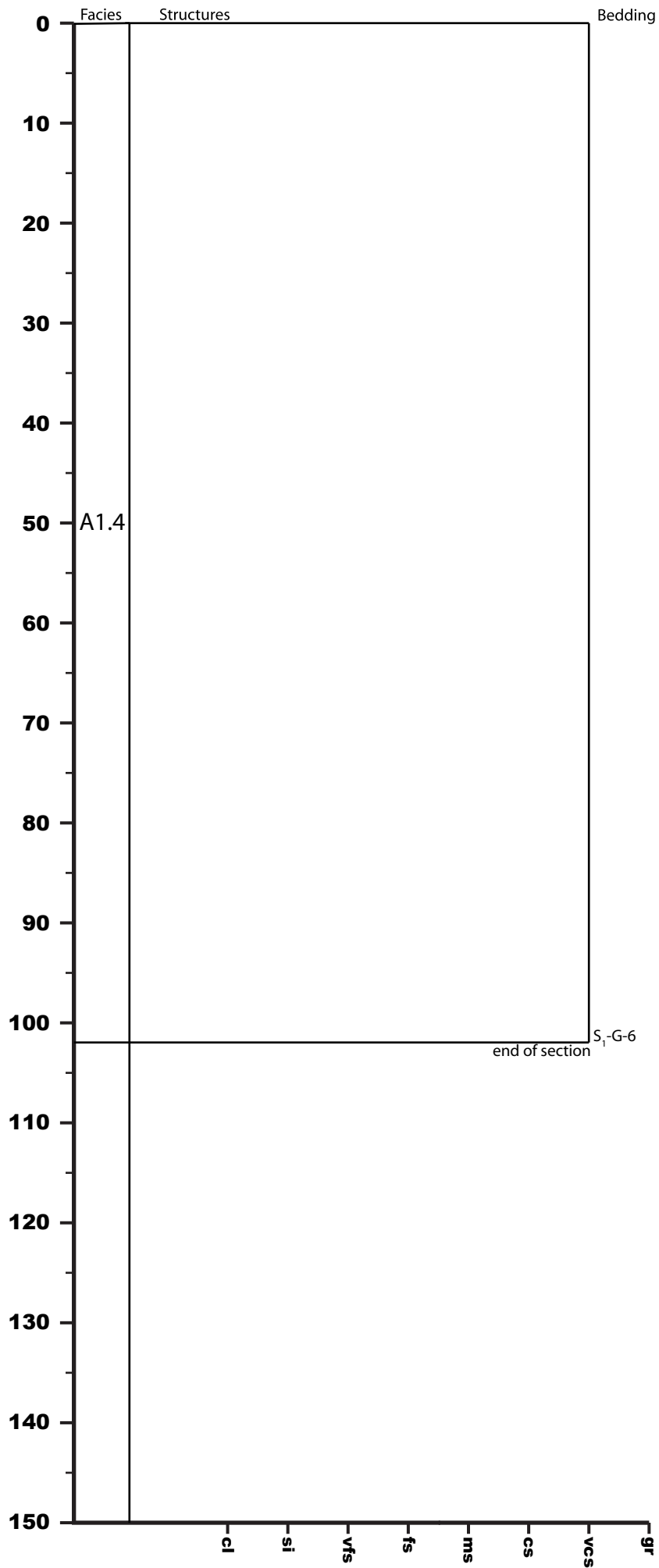

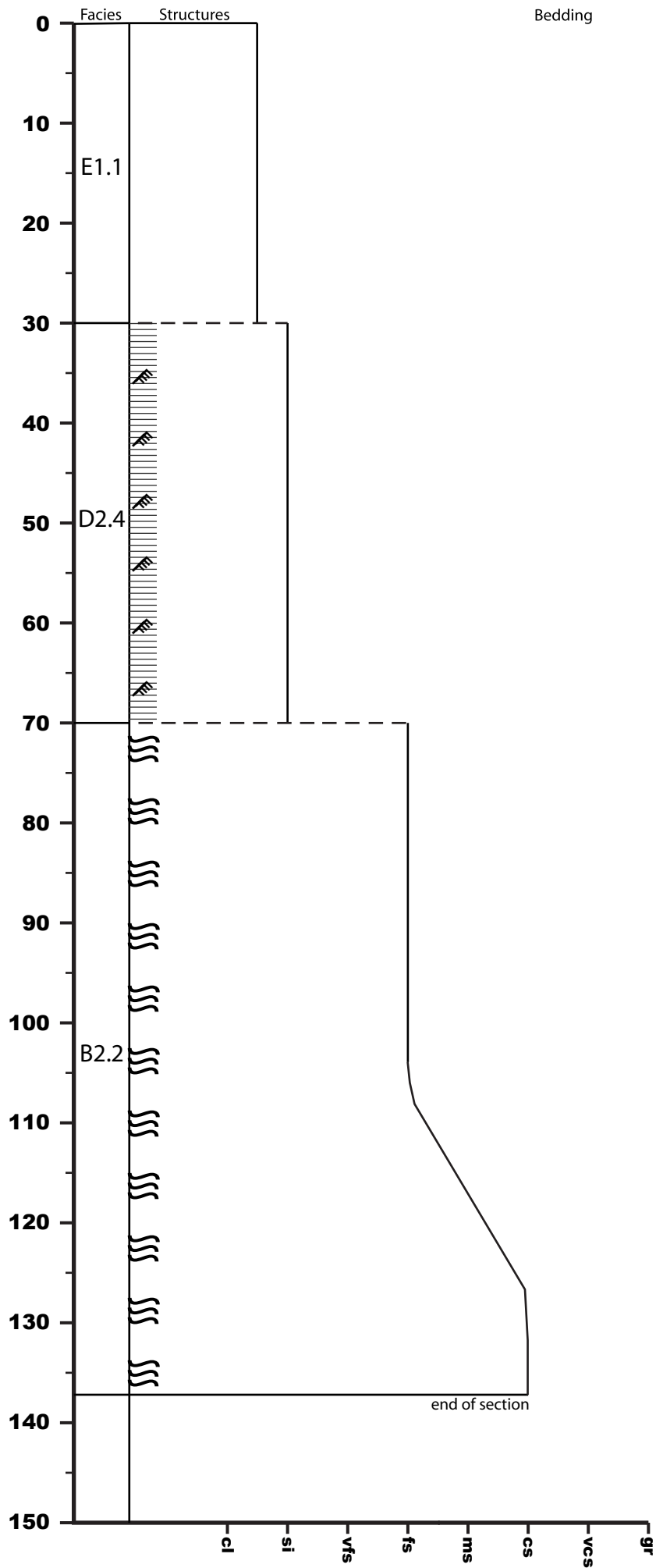

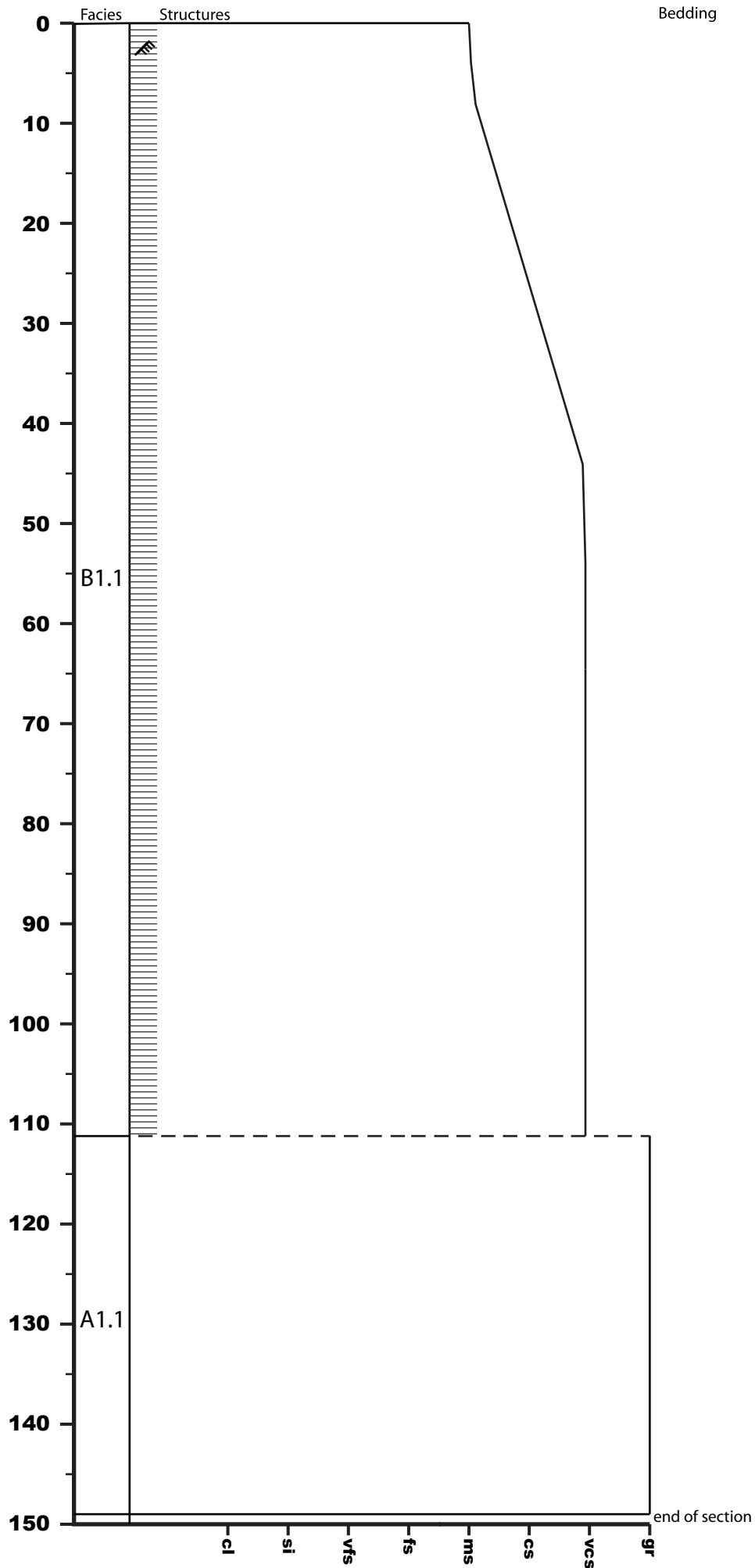

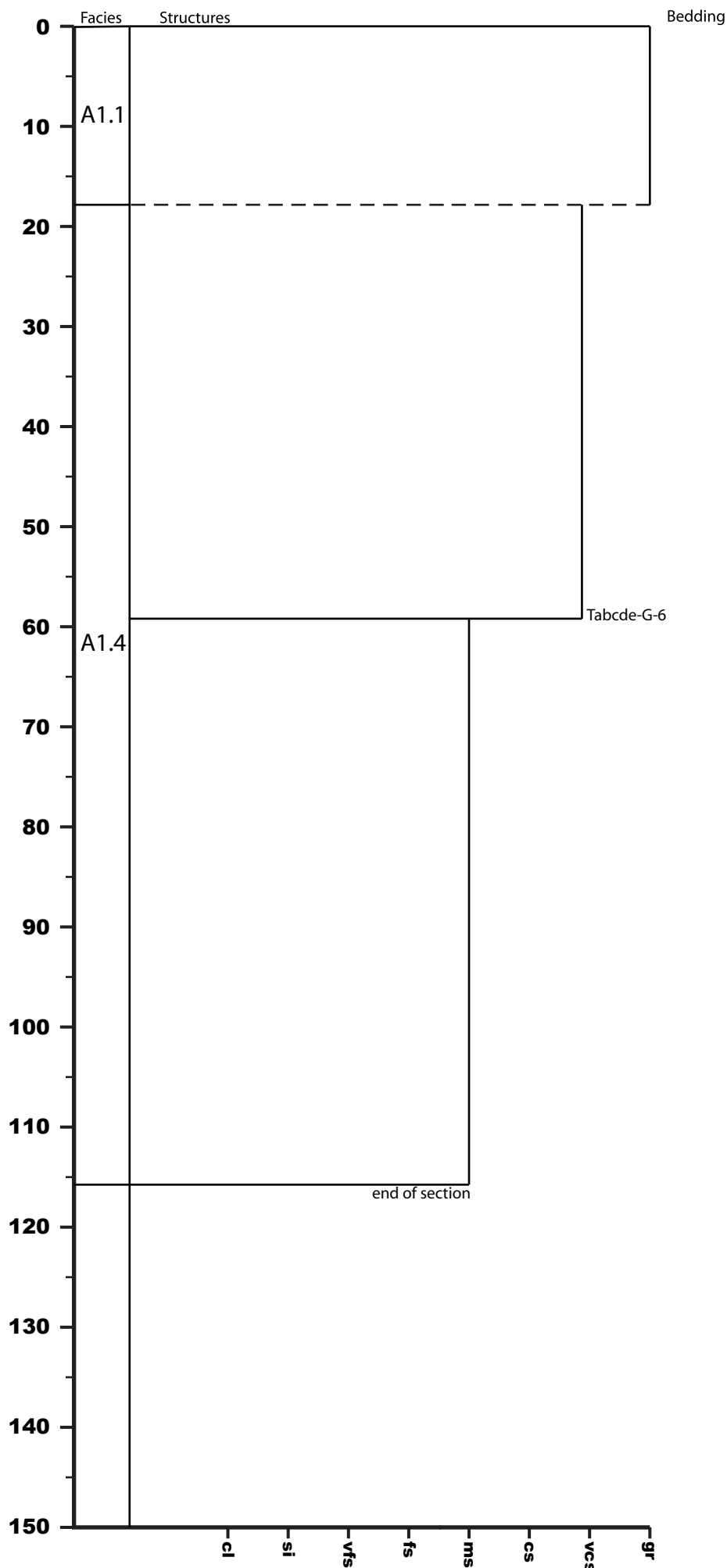

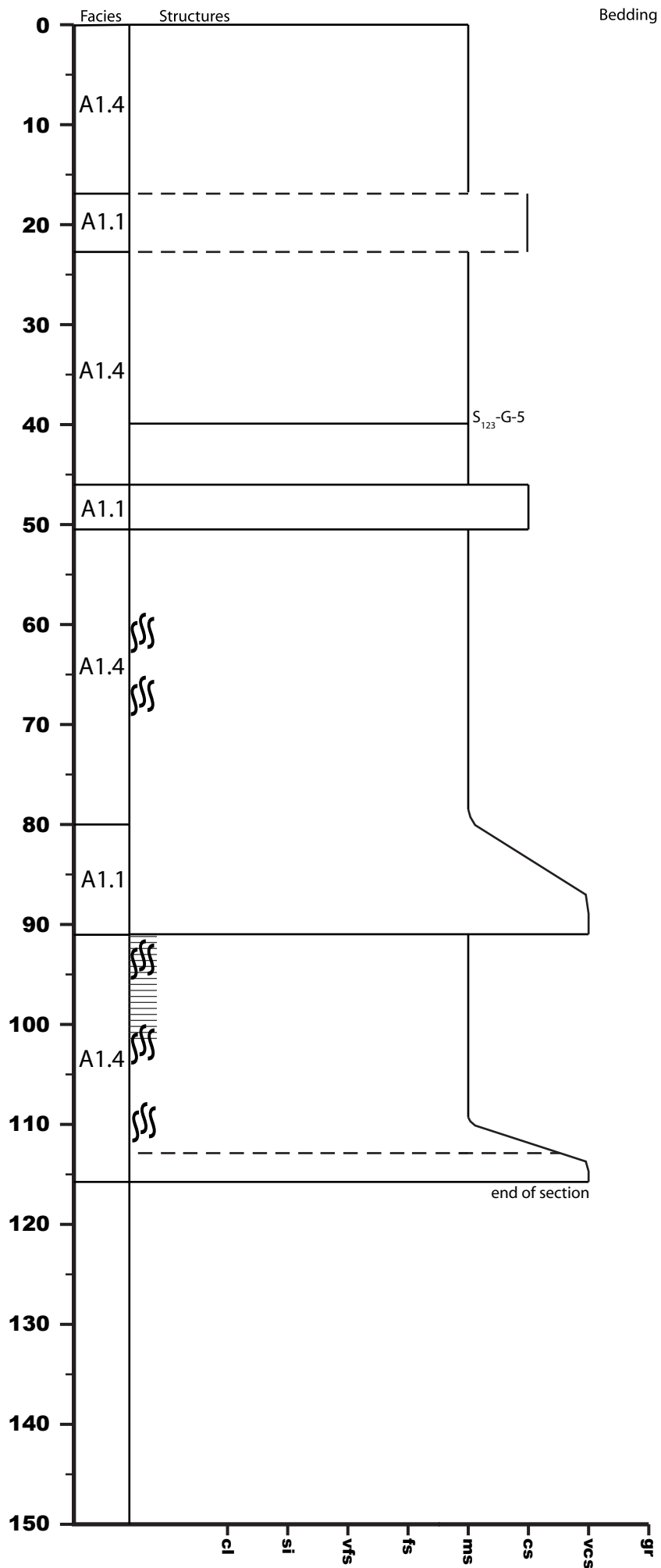



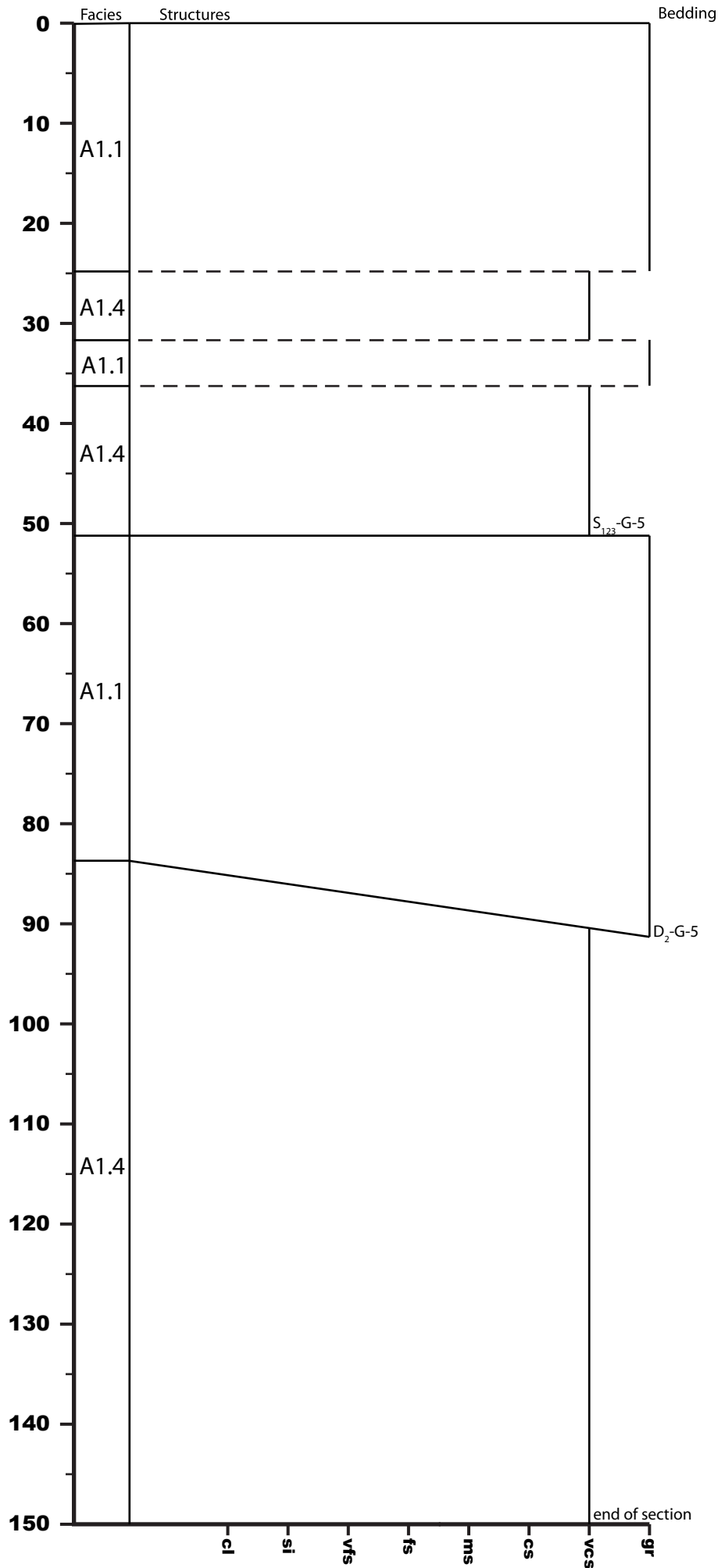

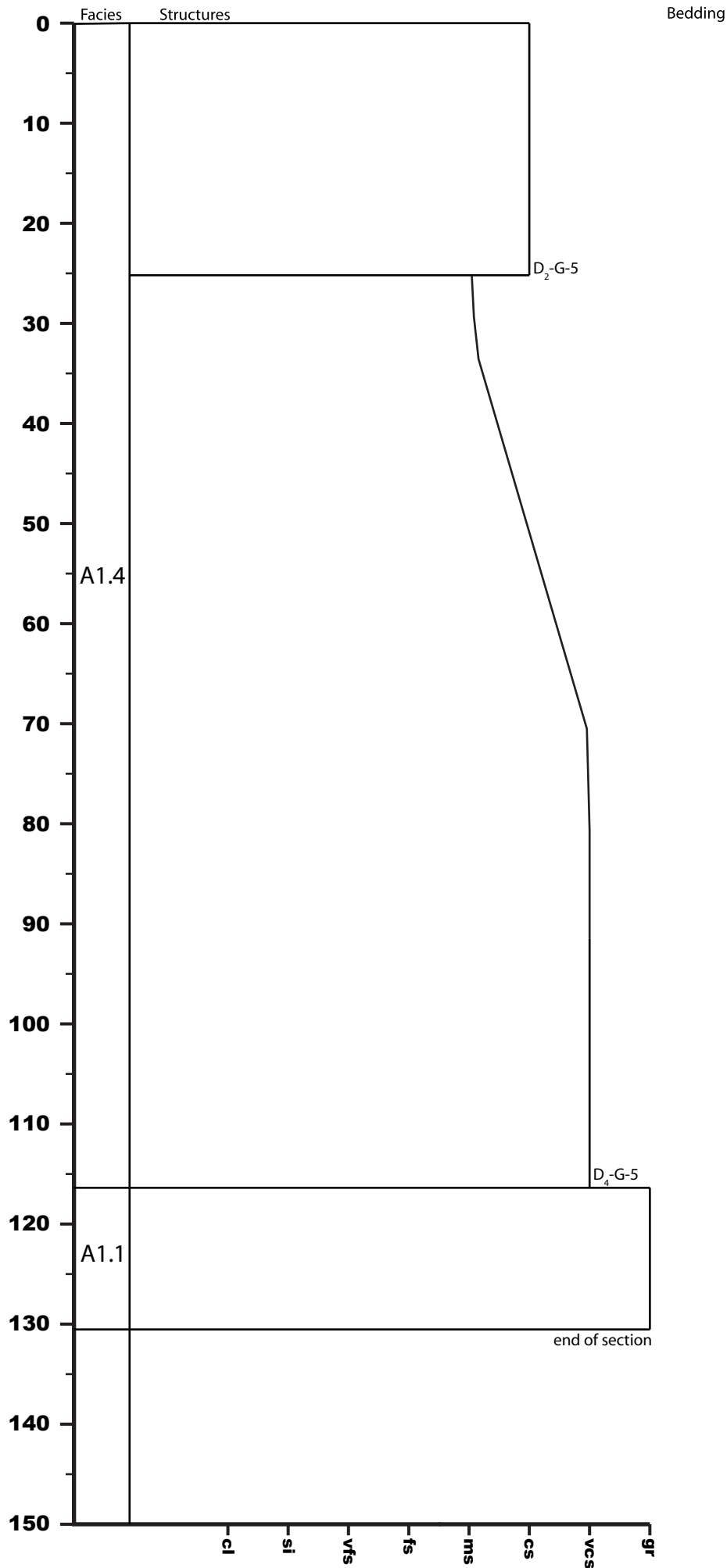

U1438E-21R-7

1040 - 1040.62 mbsf

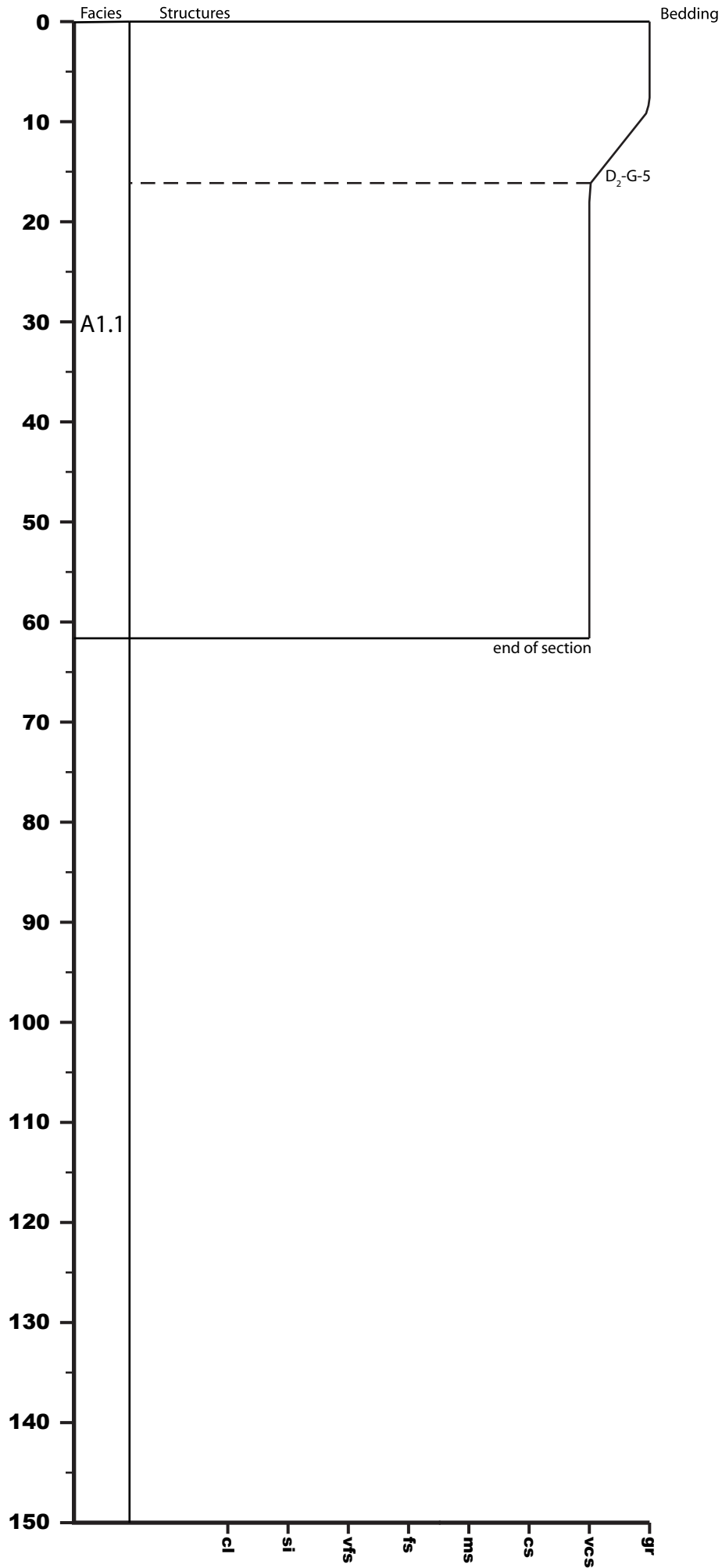

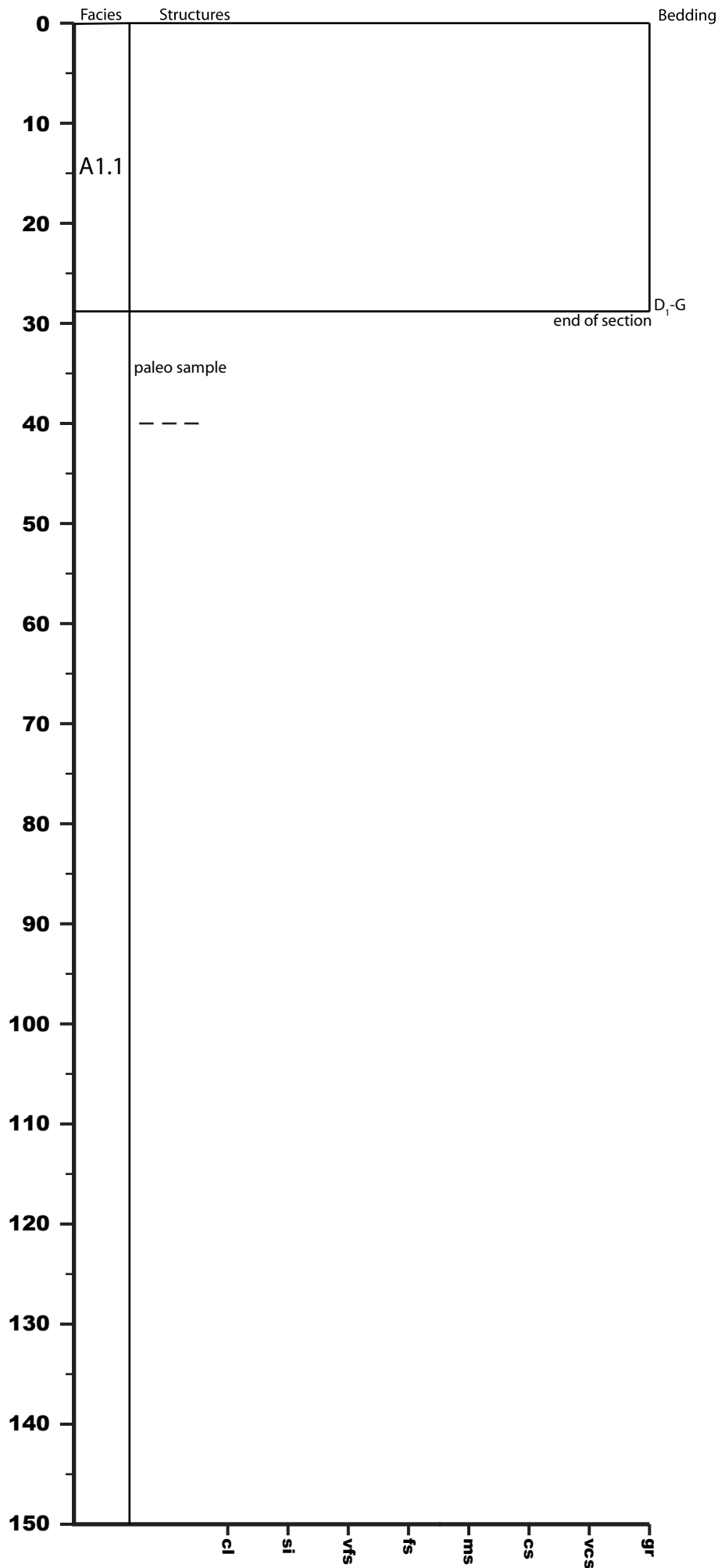

U1438E-22R-1

1041.7 - 1043.04 mbsf

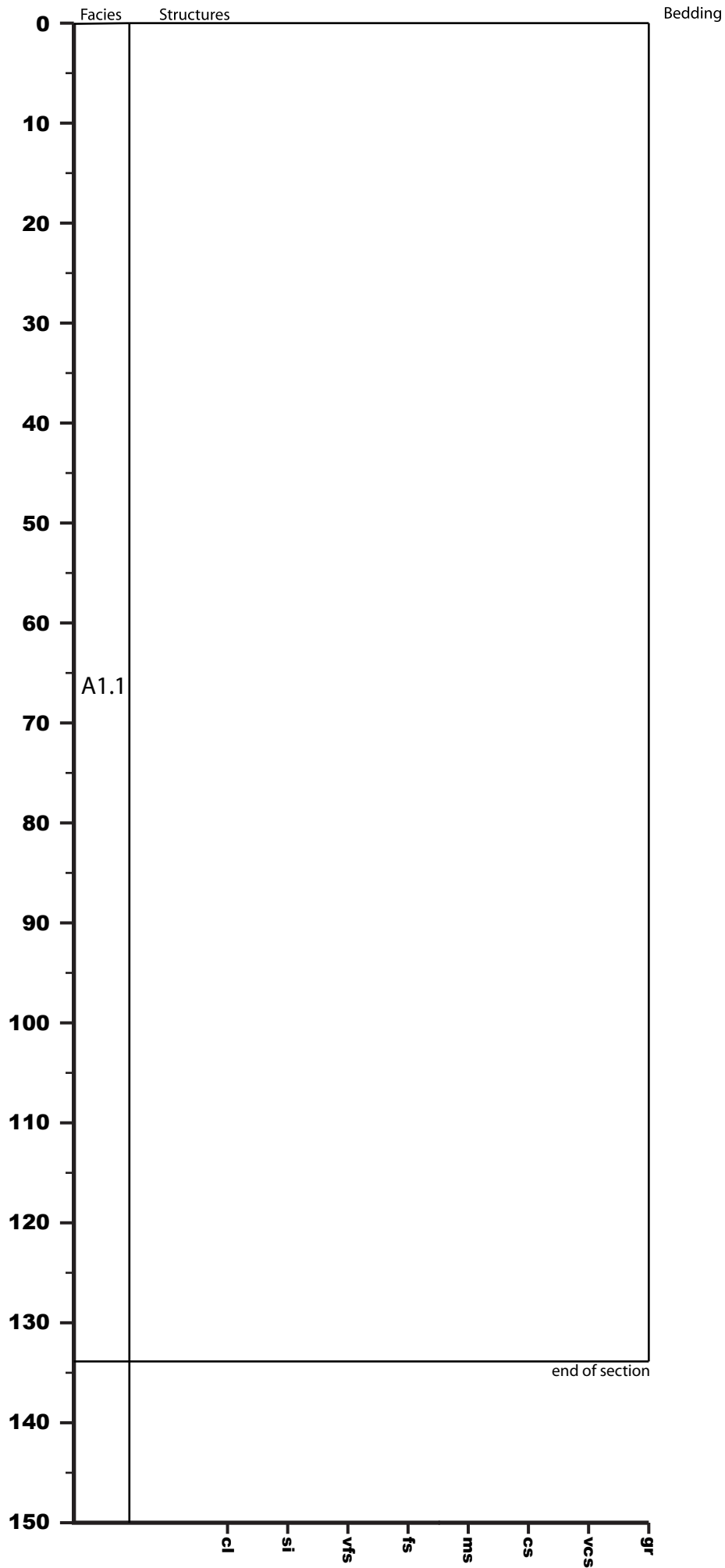

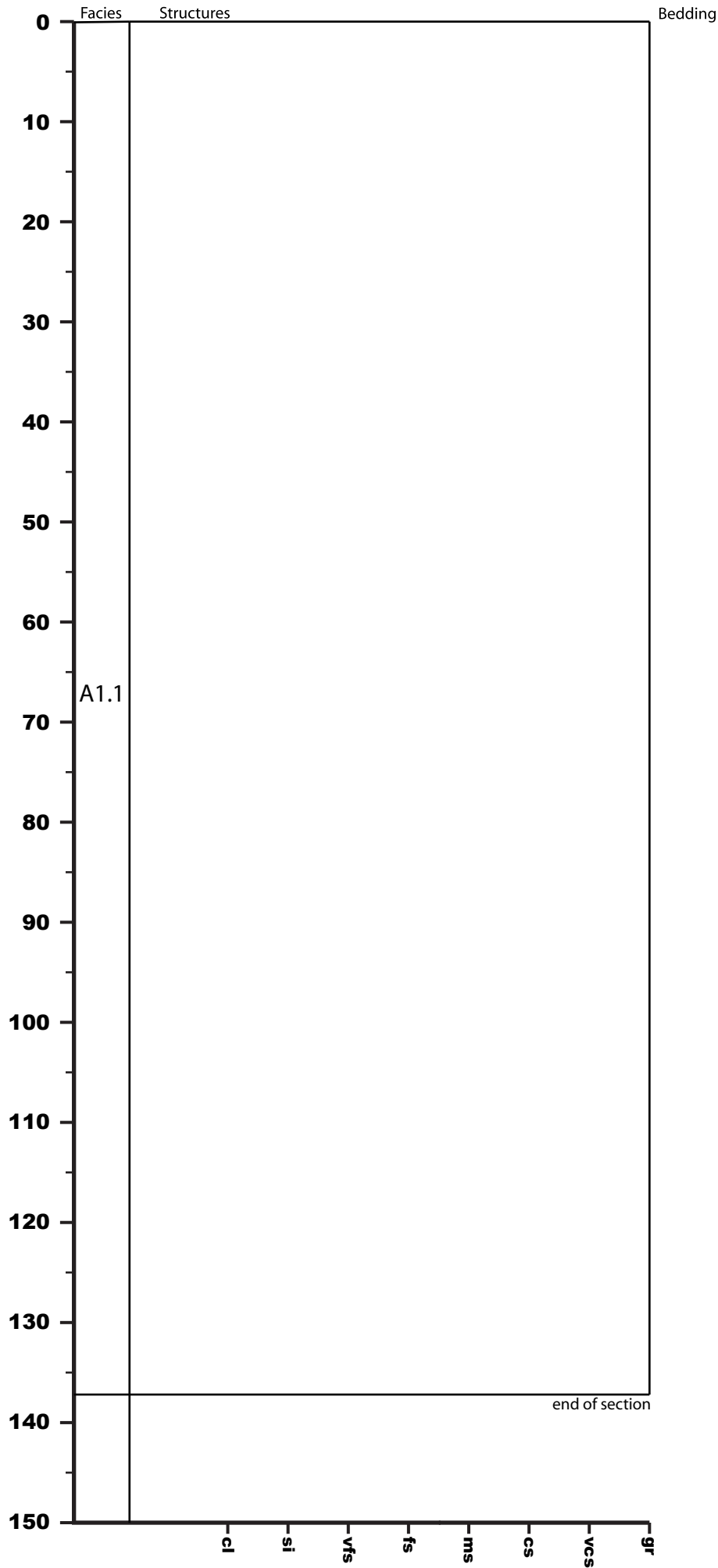

U1438E-22R-3

1044.41 - 1045.91 mbsf

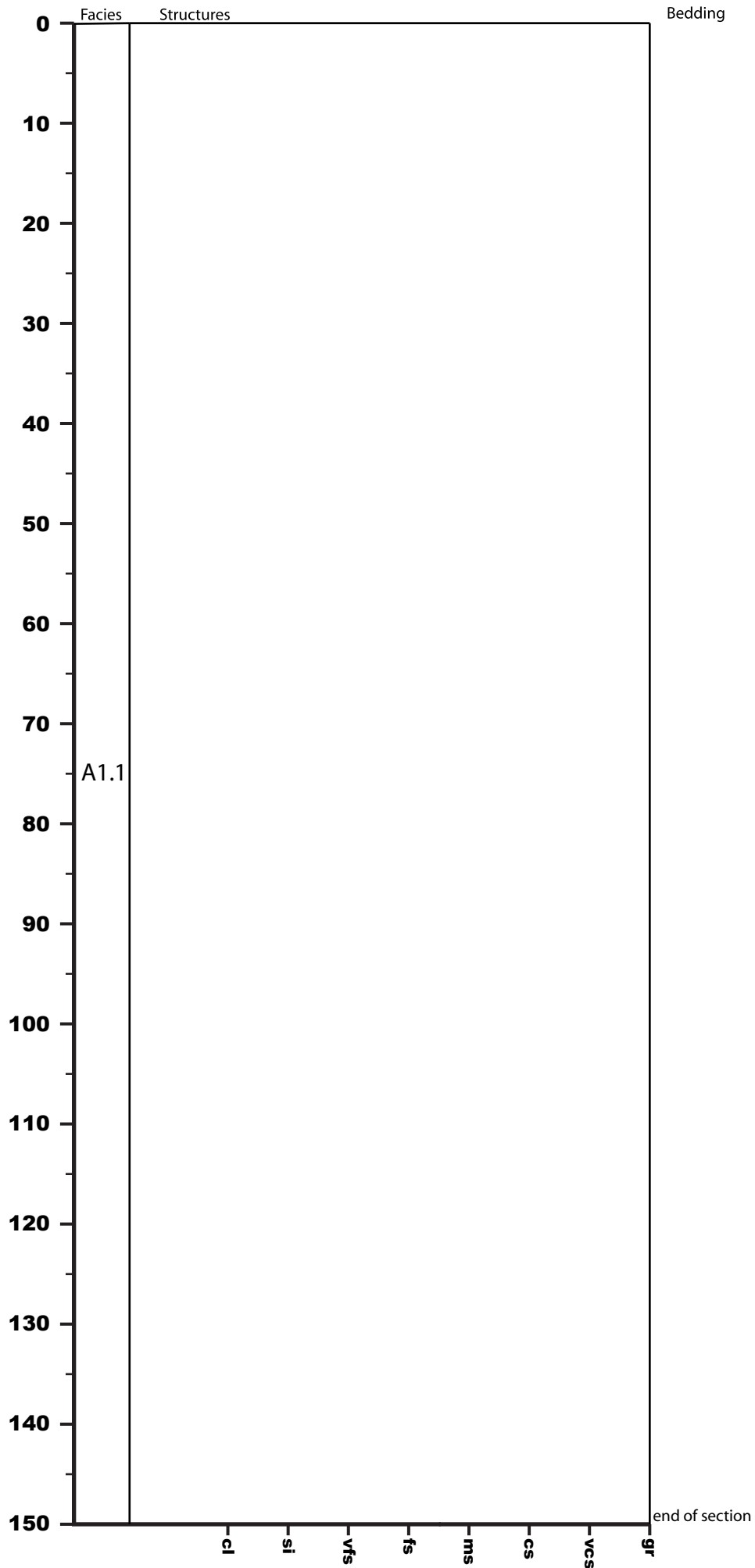

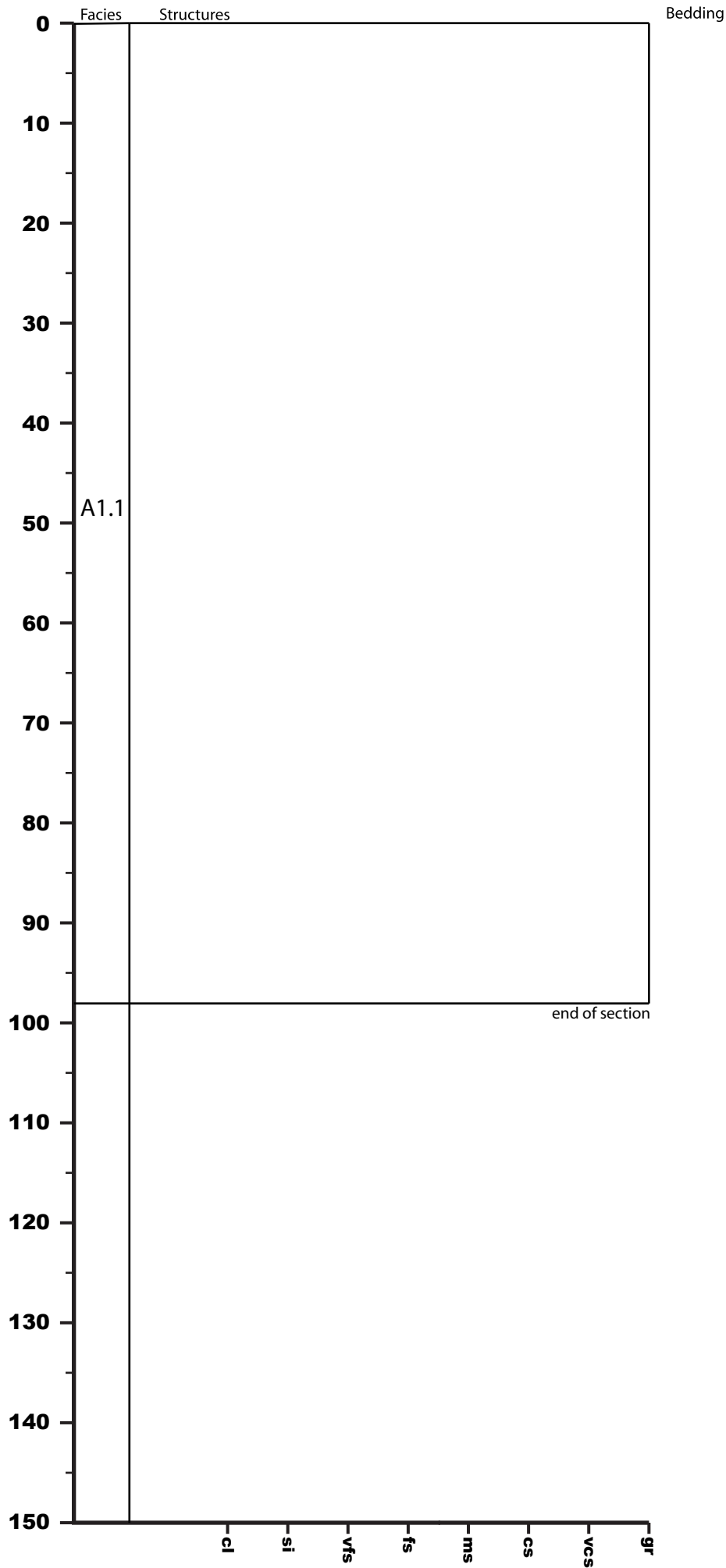



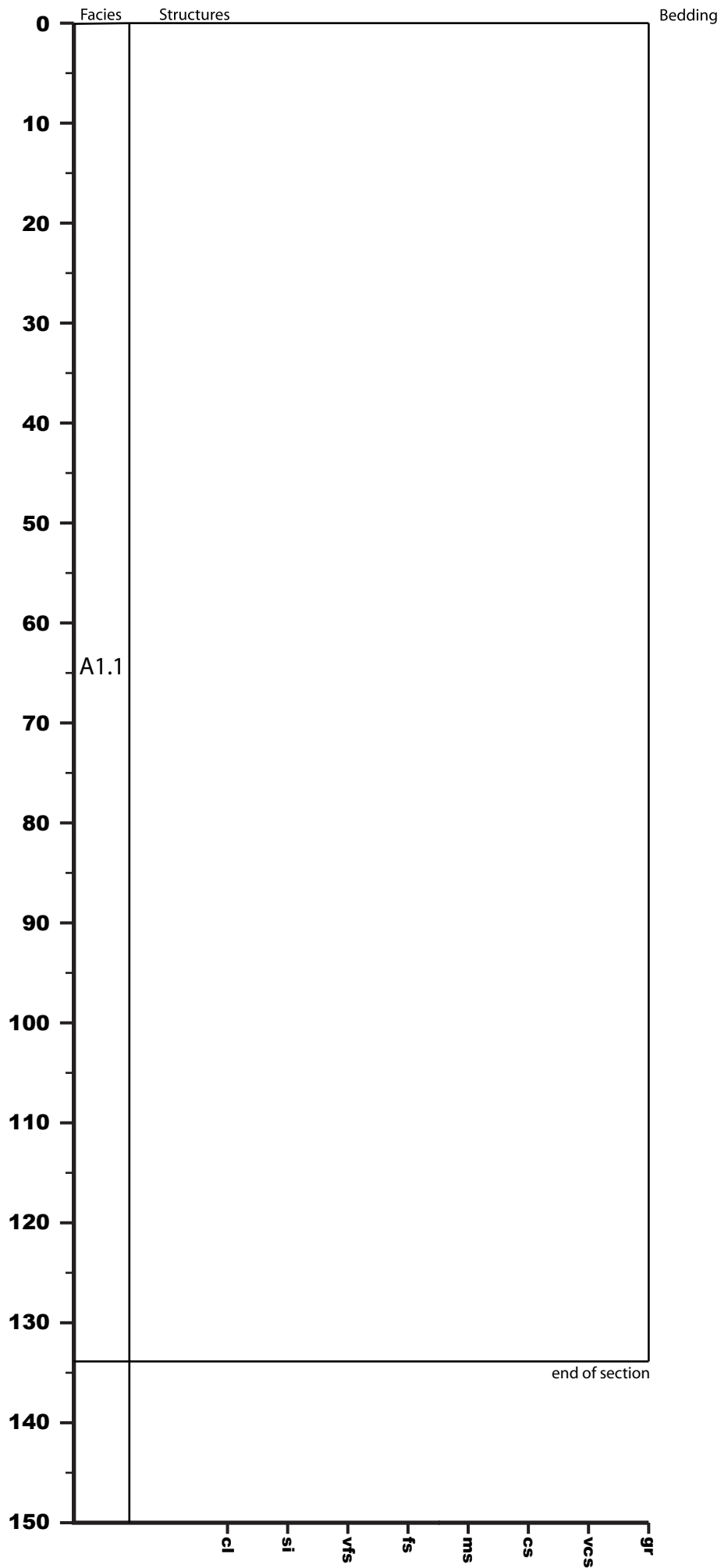

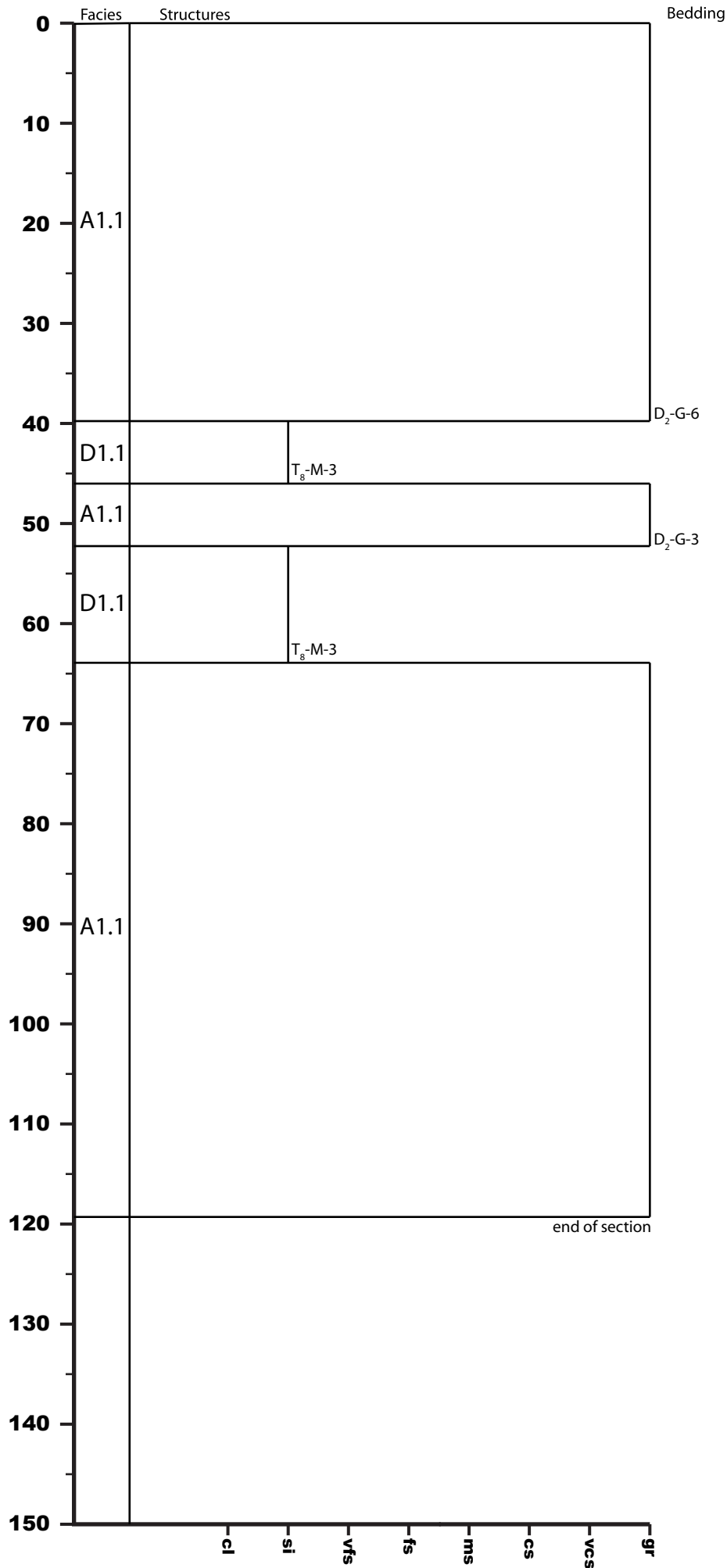

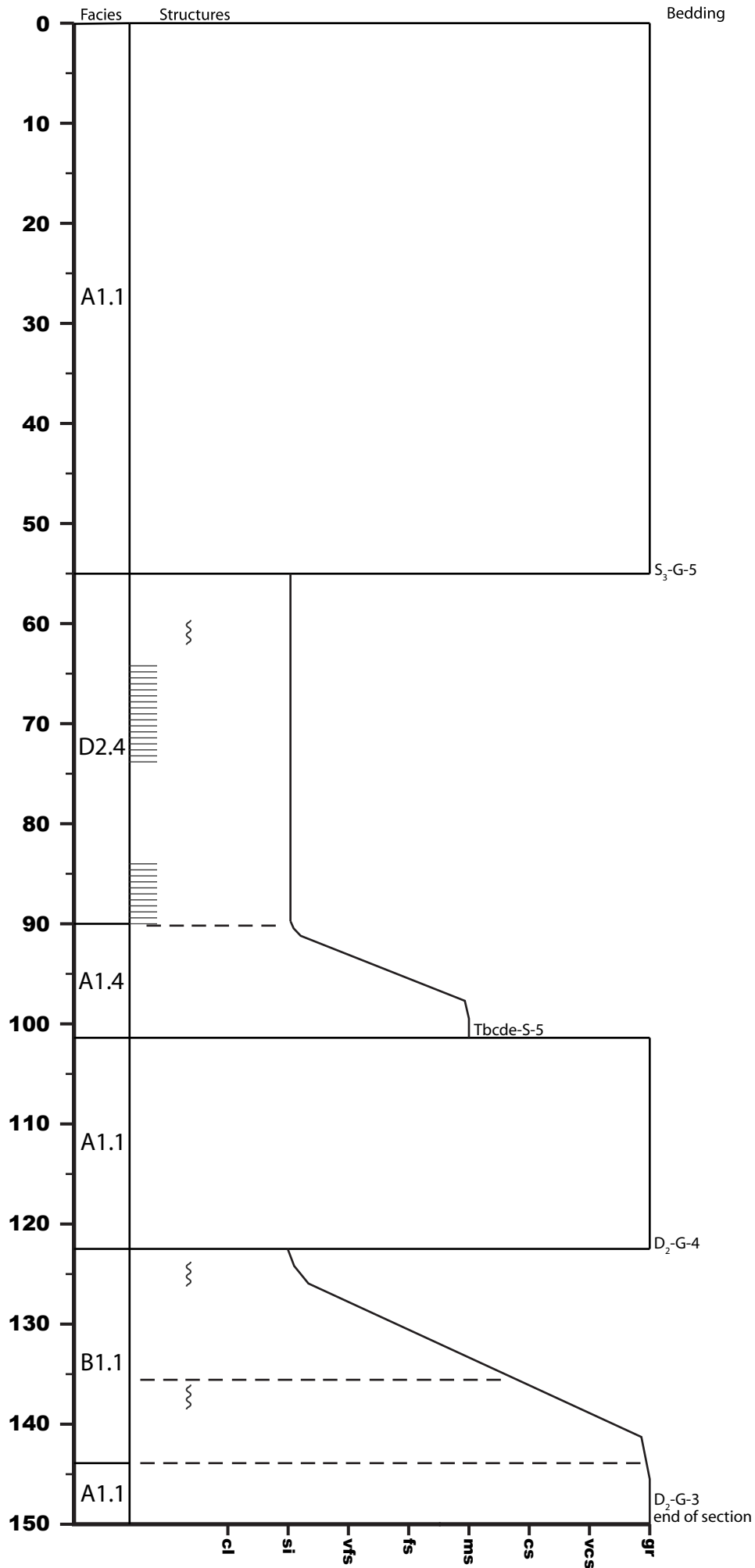

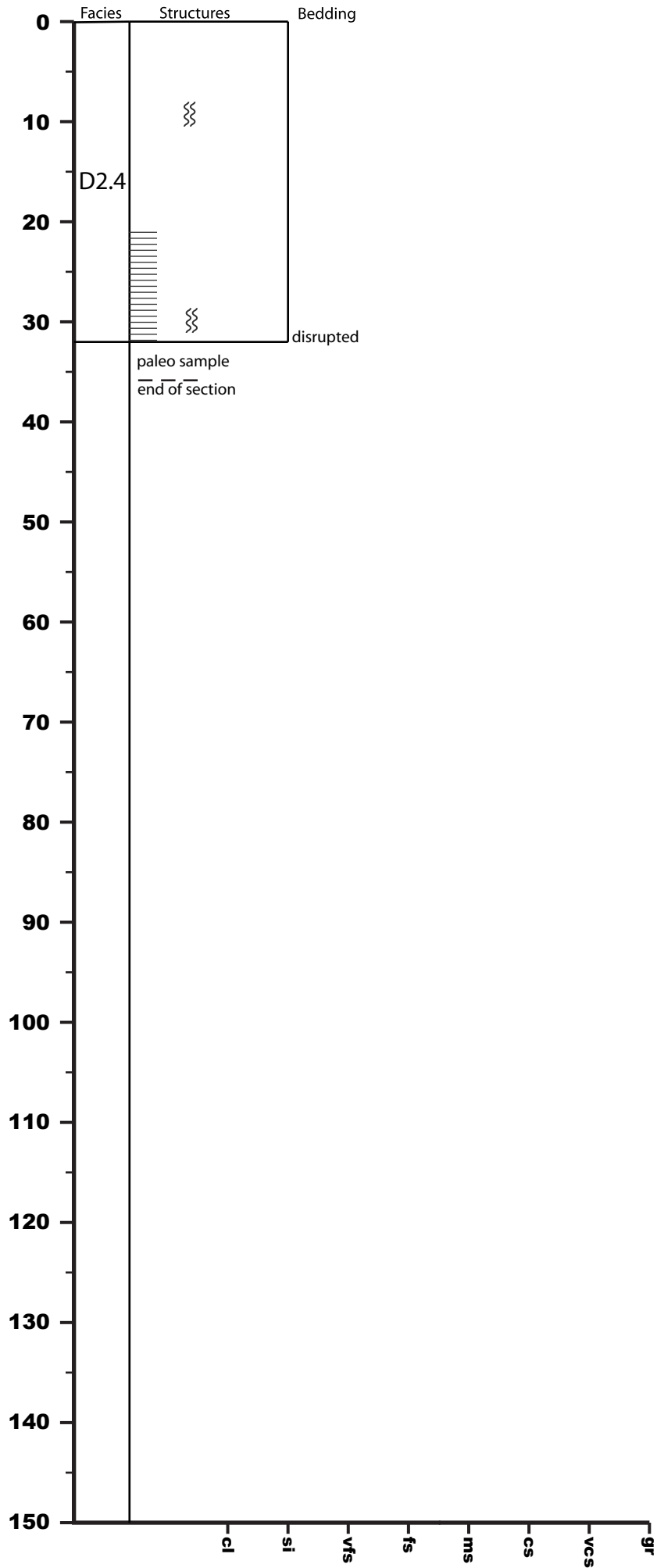

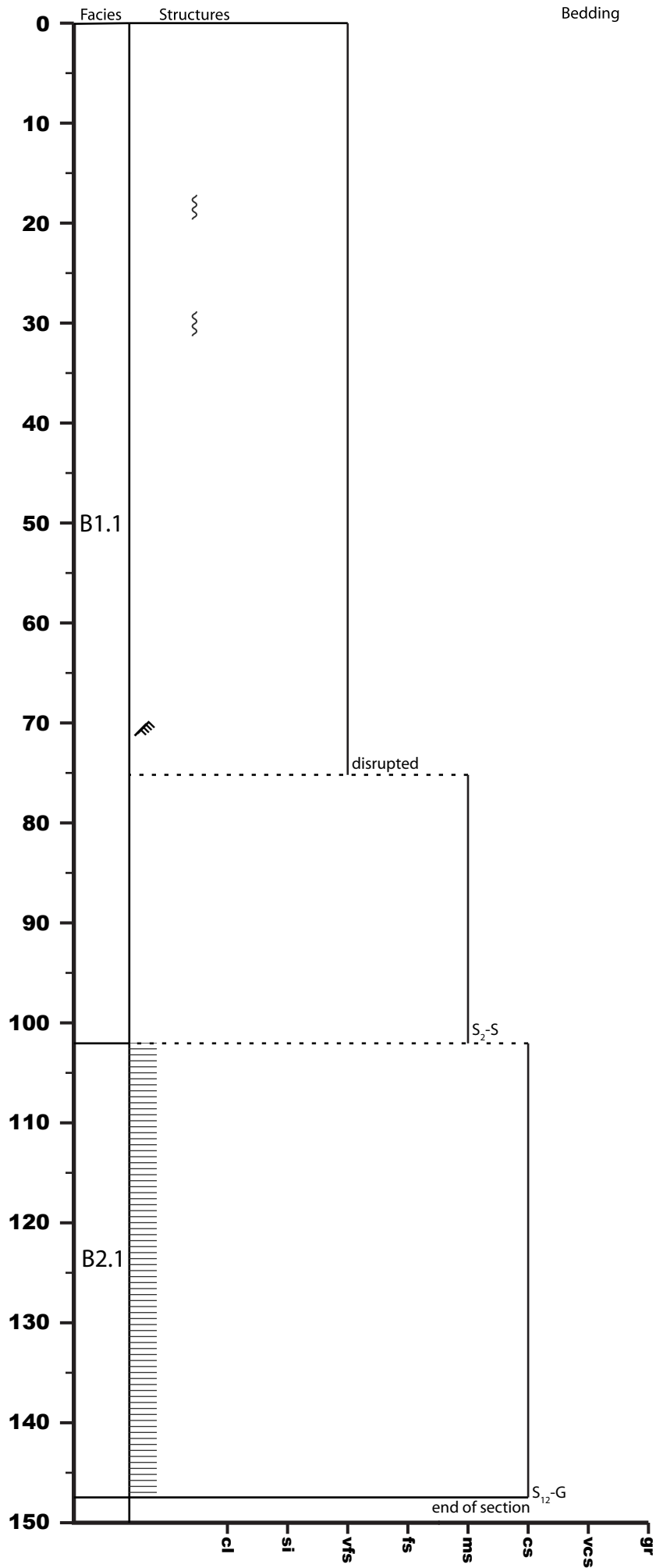

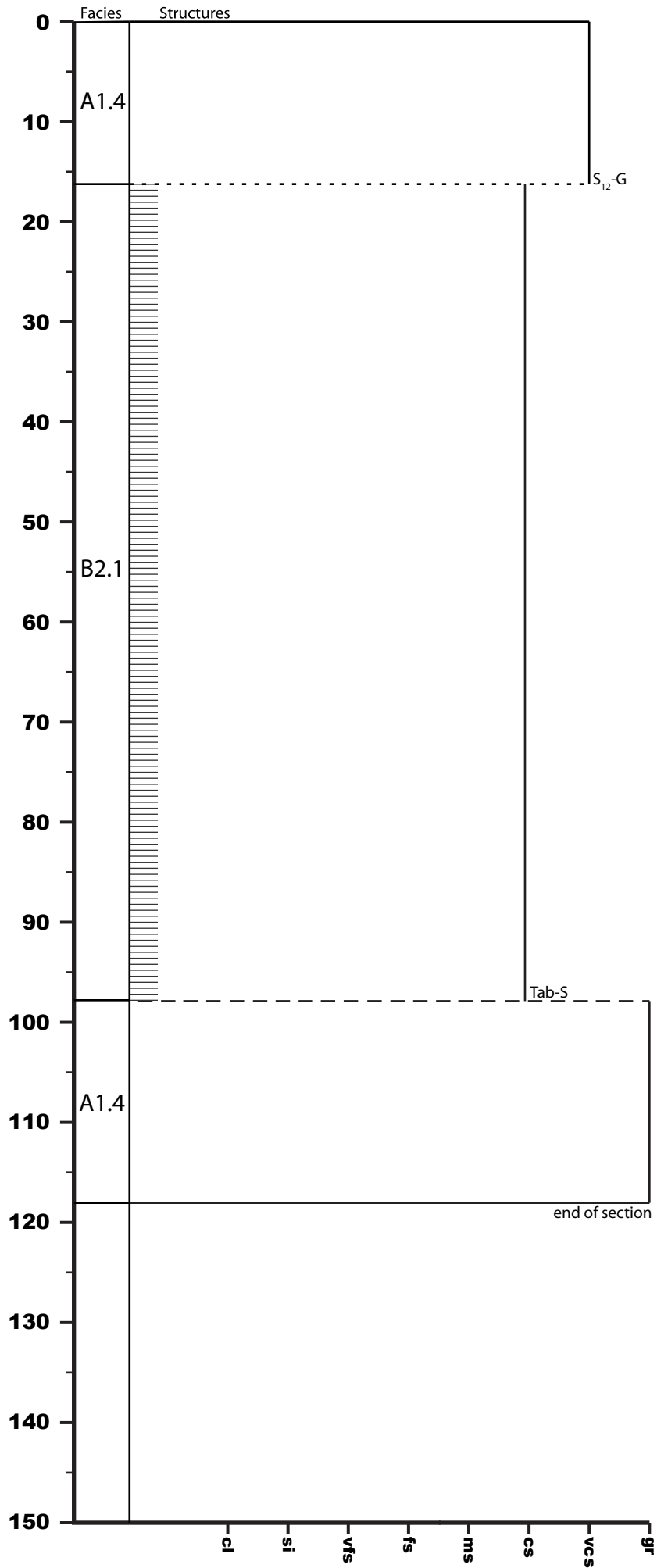

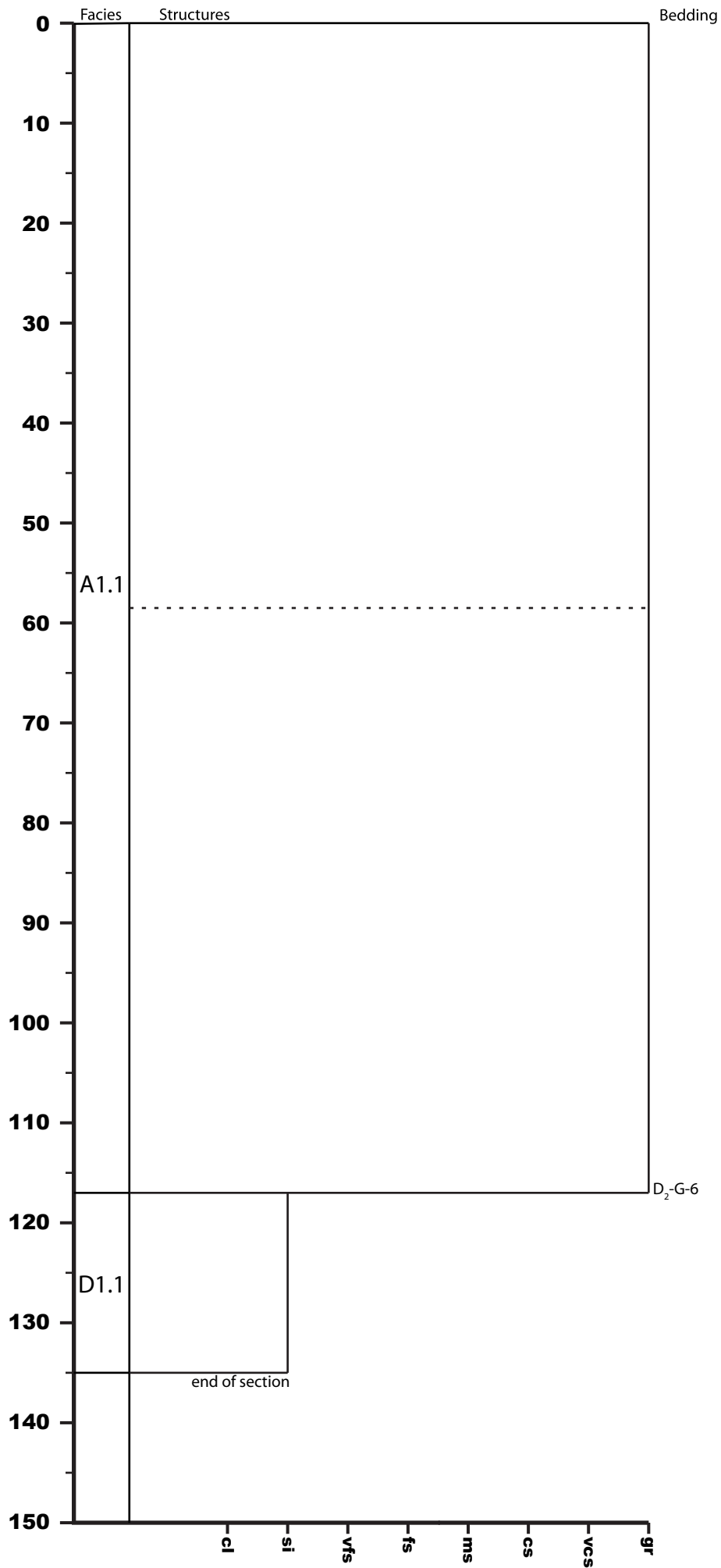

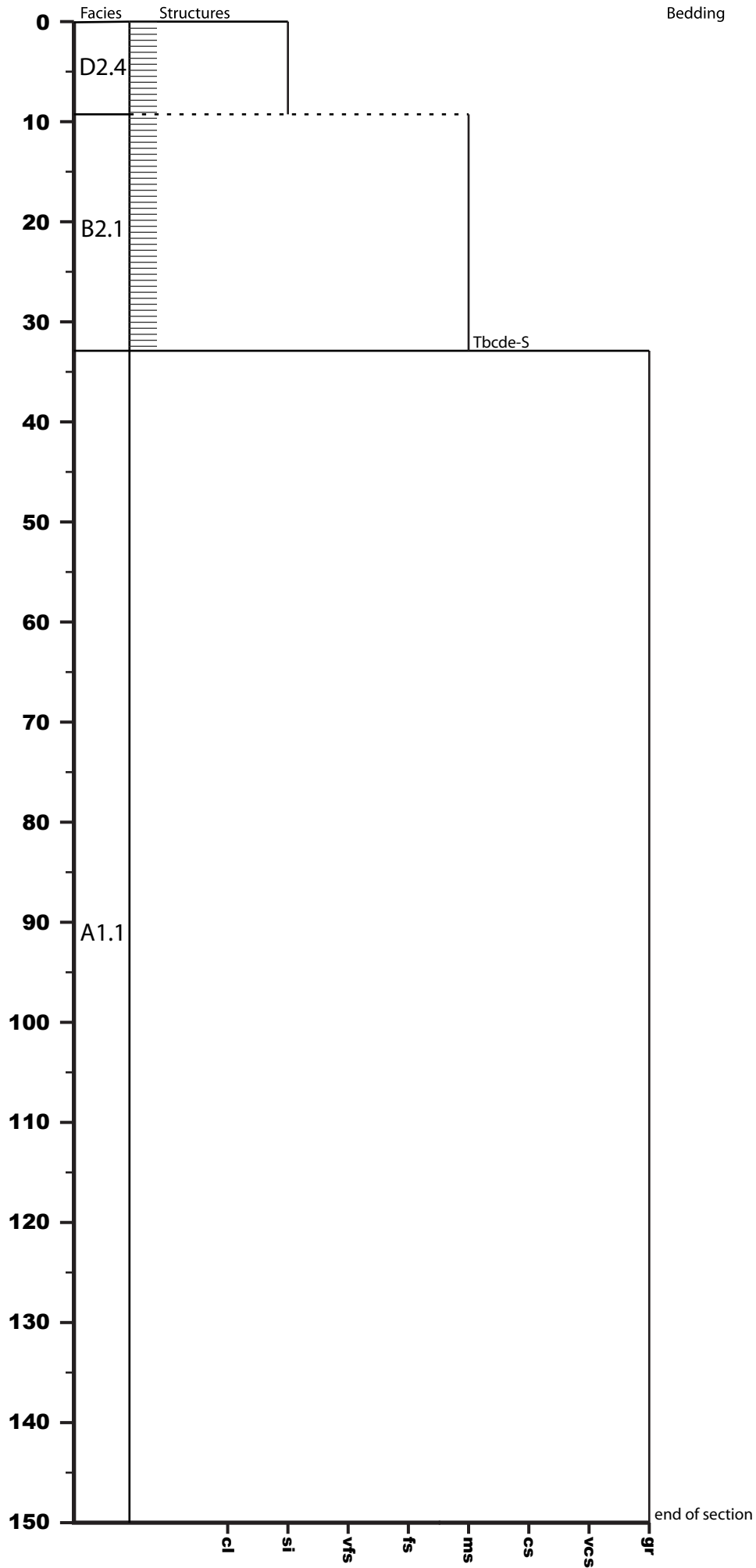



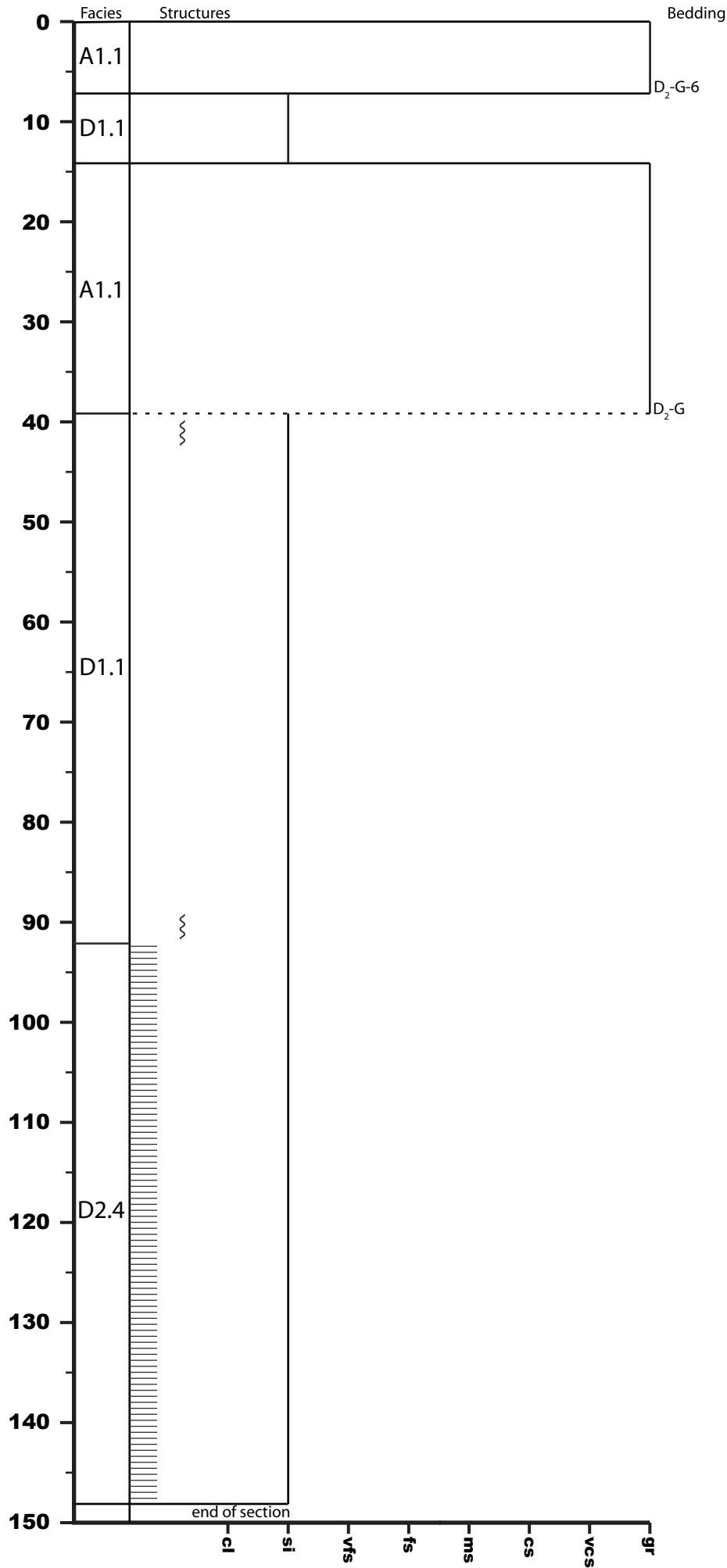

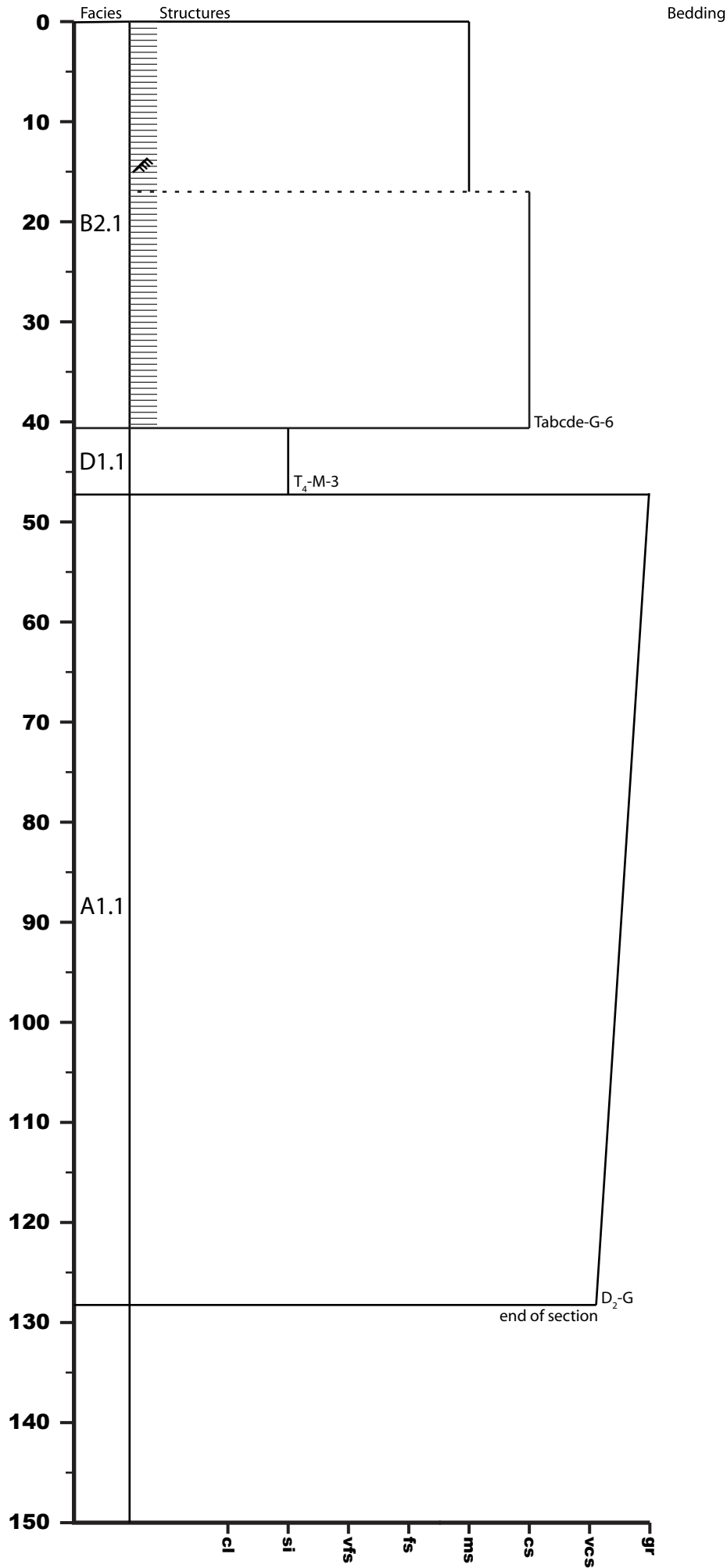

U1438E-23R-7

1059.66 - 1060.46 mbsf

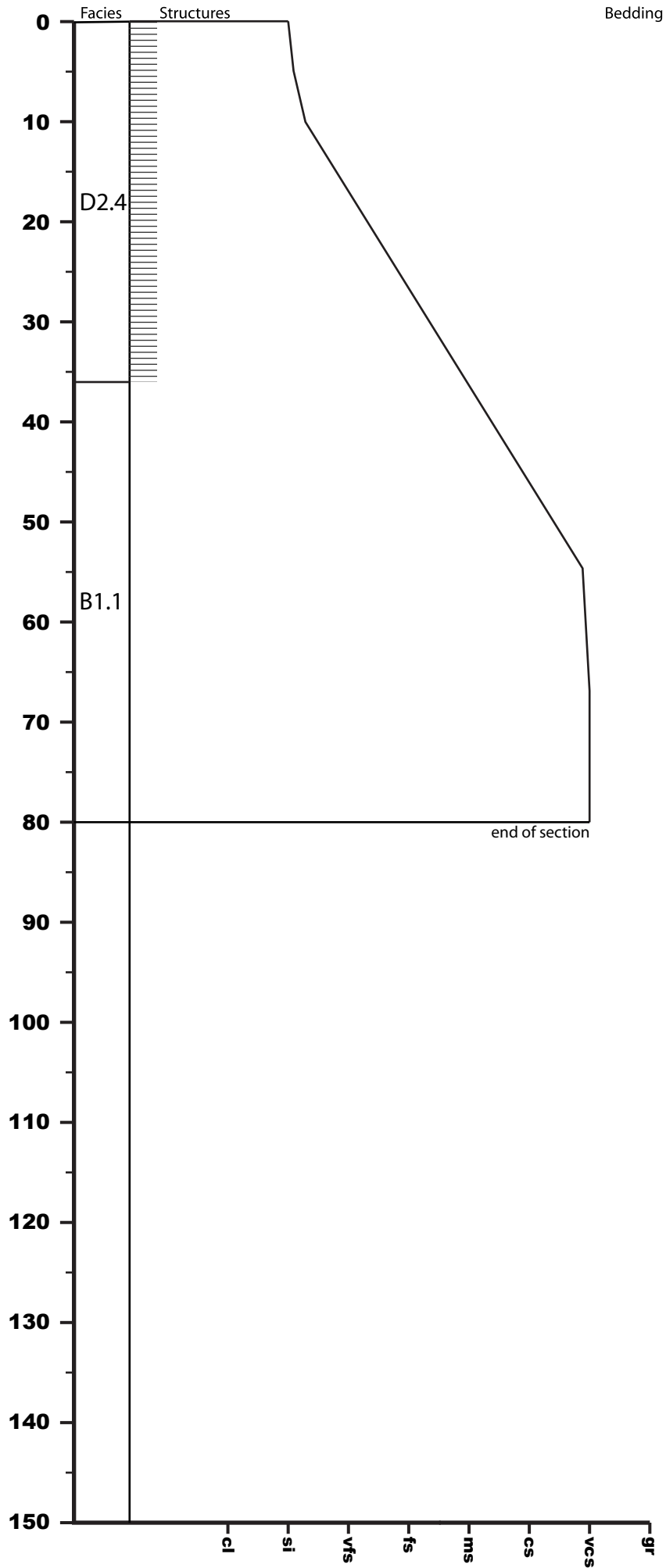

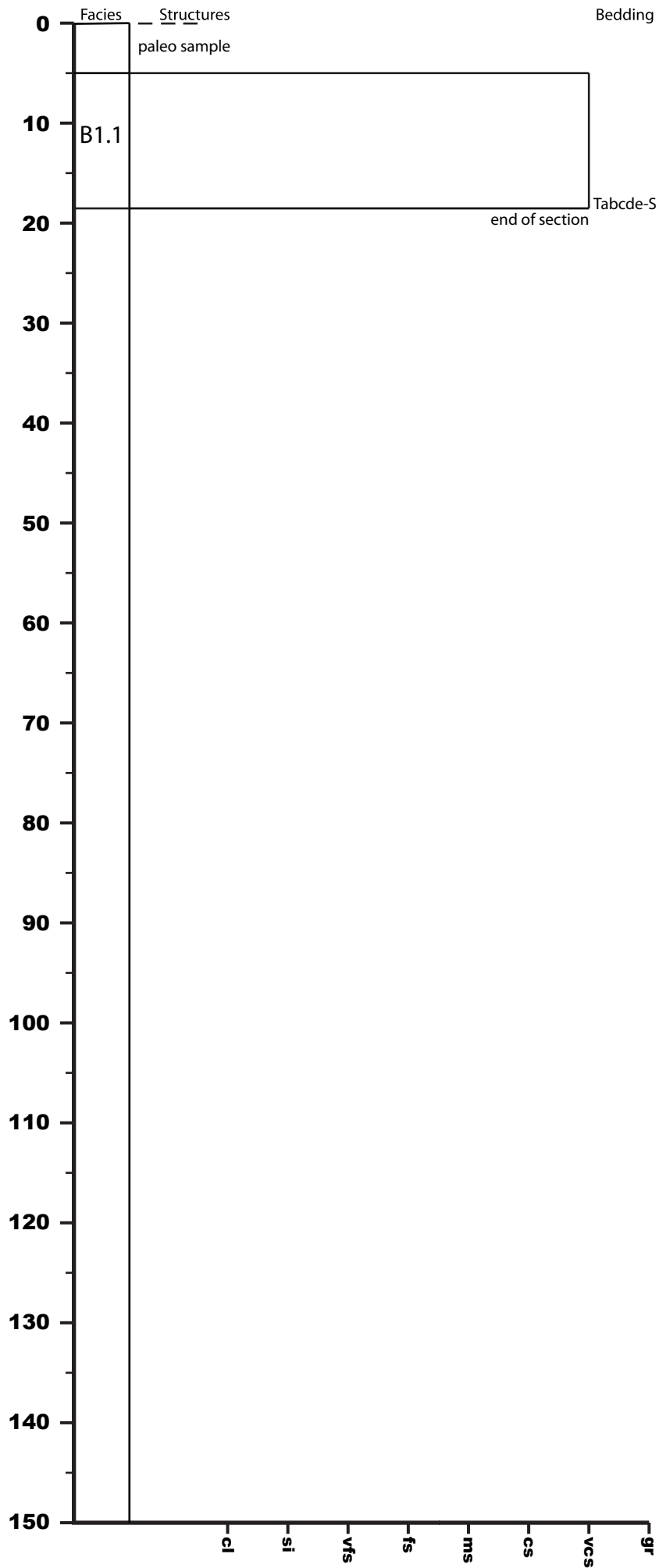

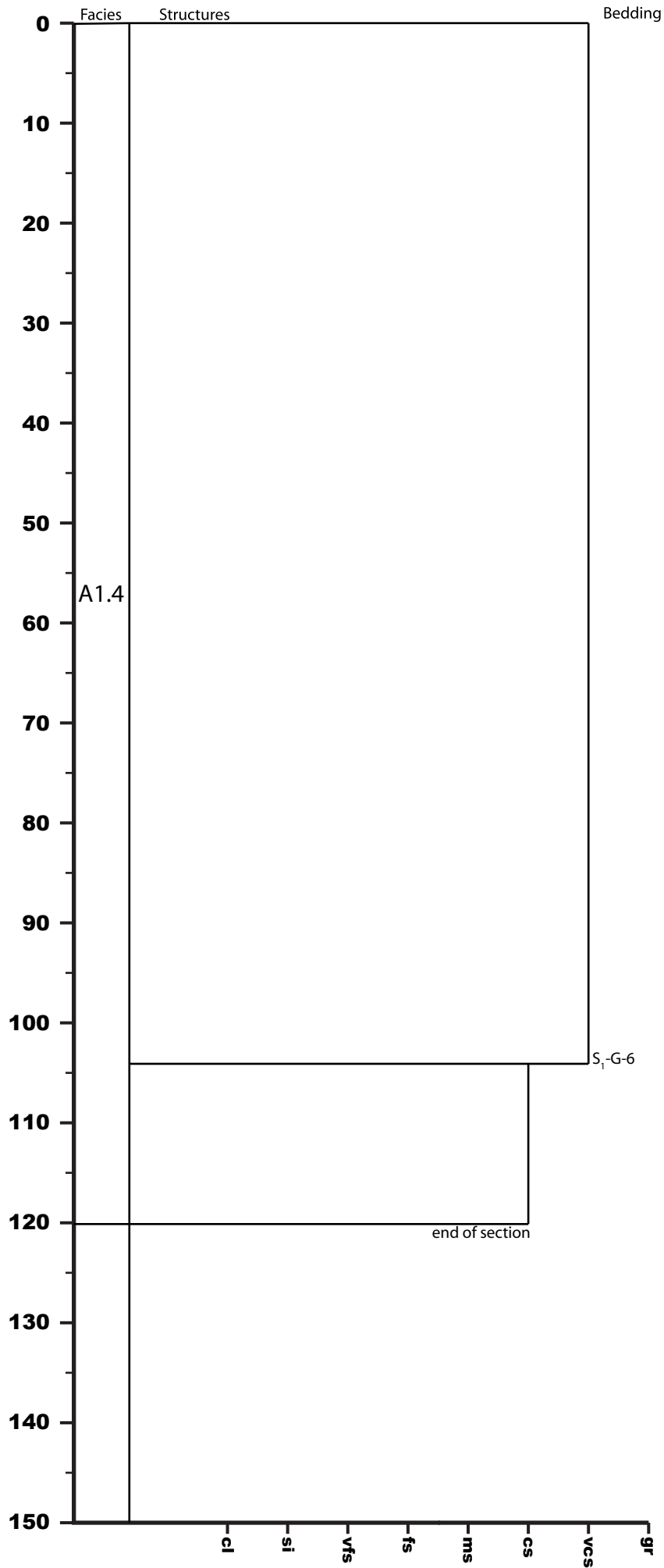

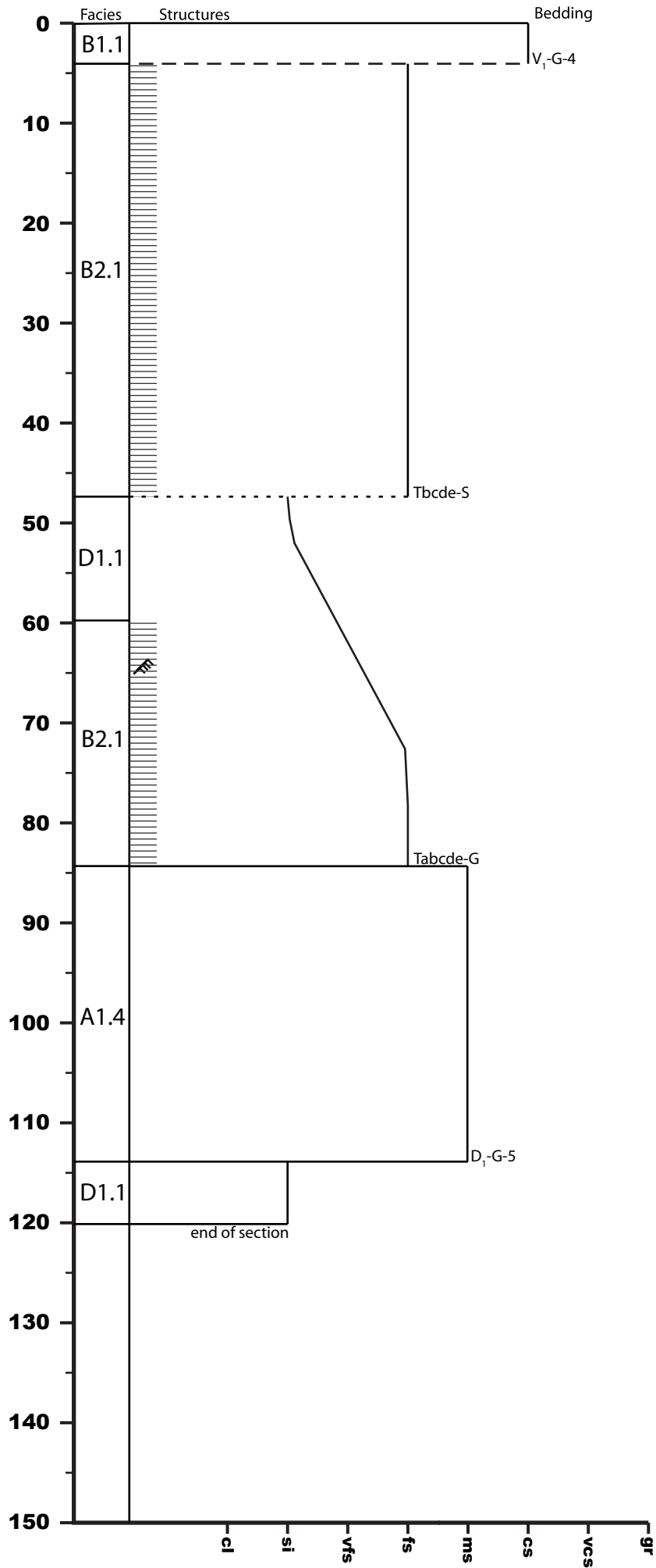

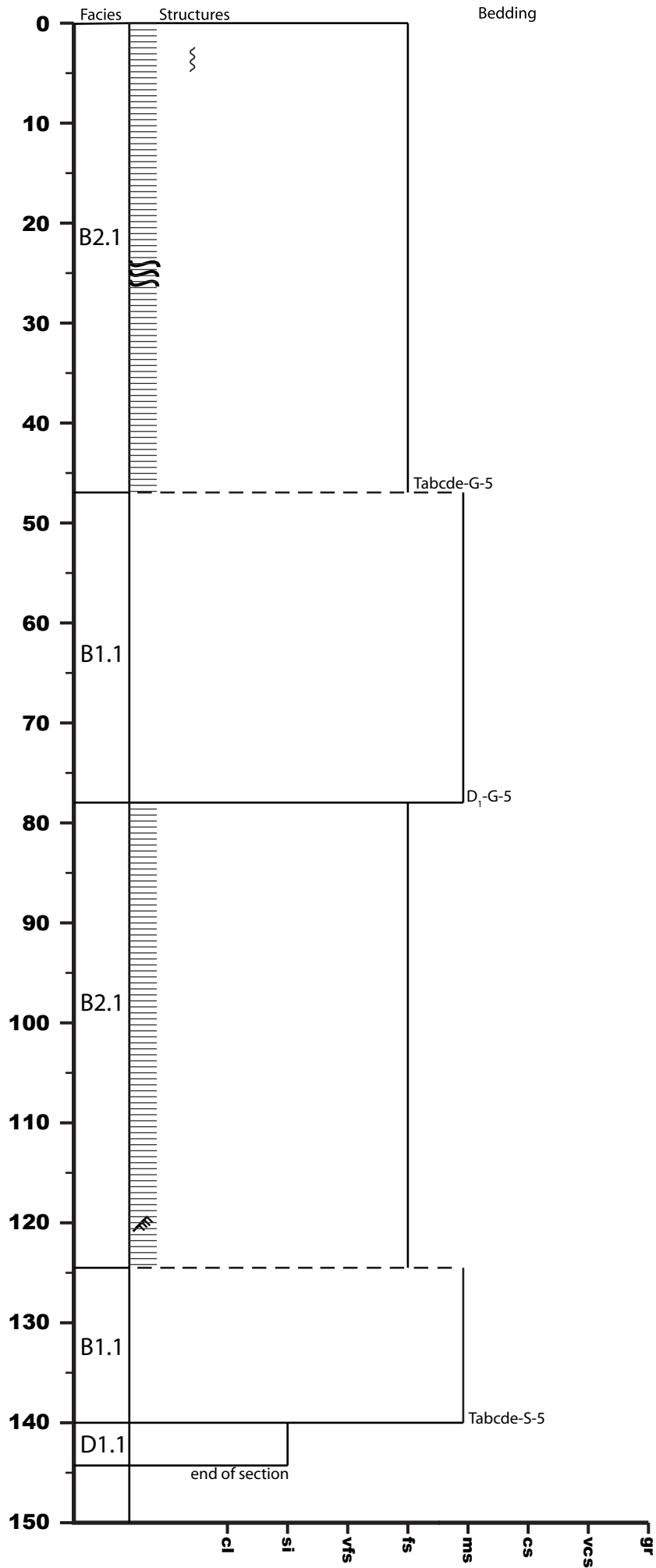

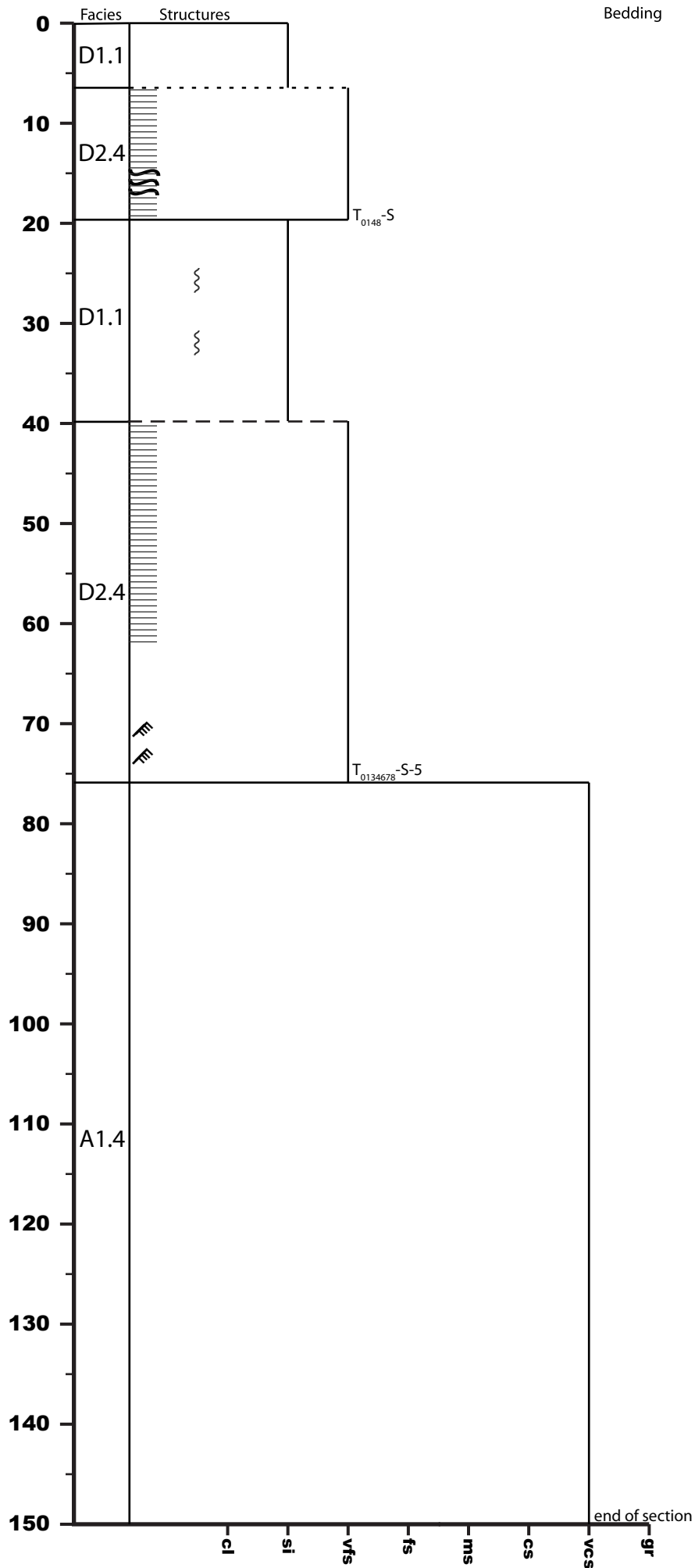



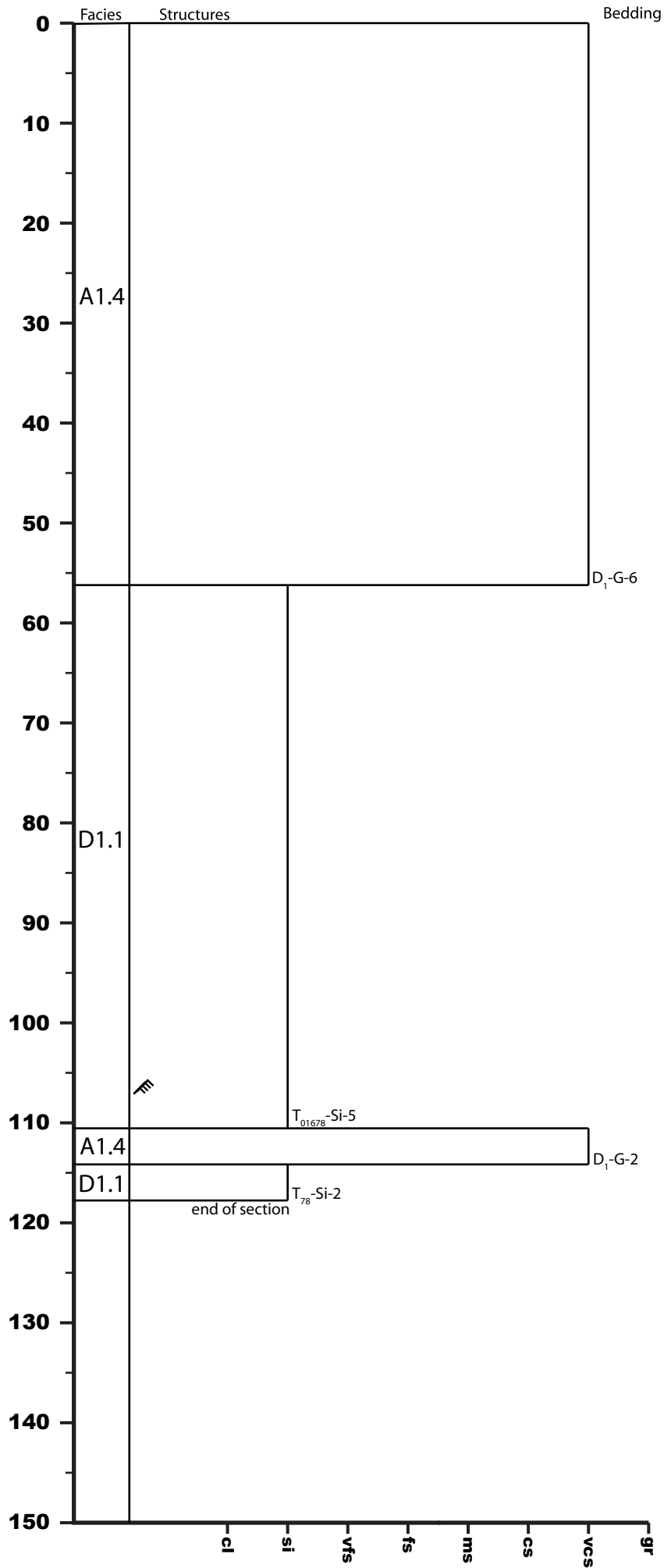

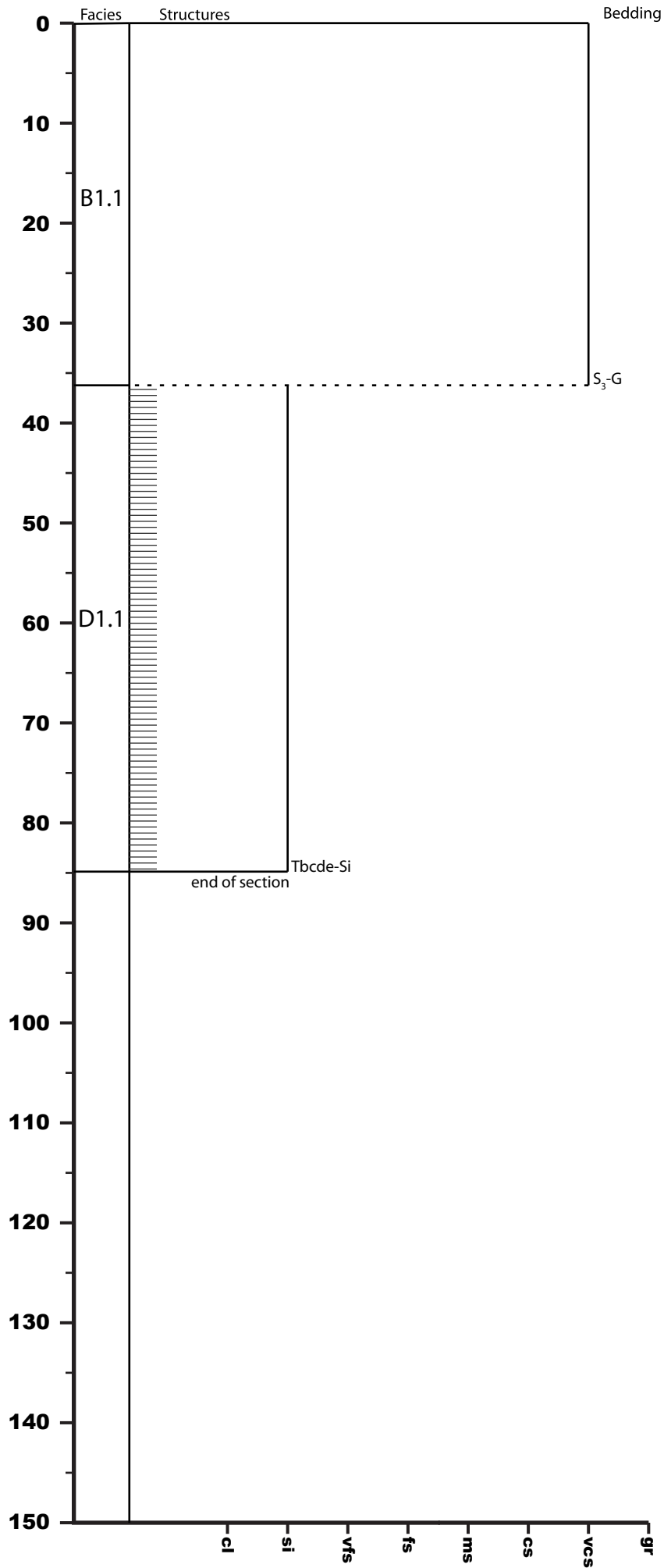

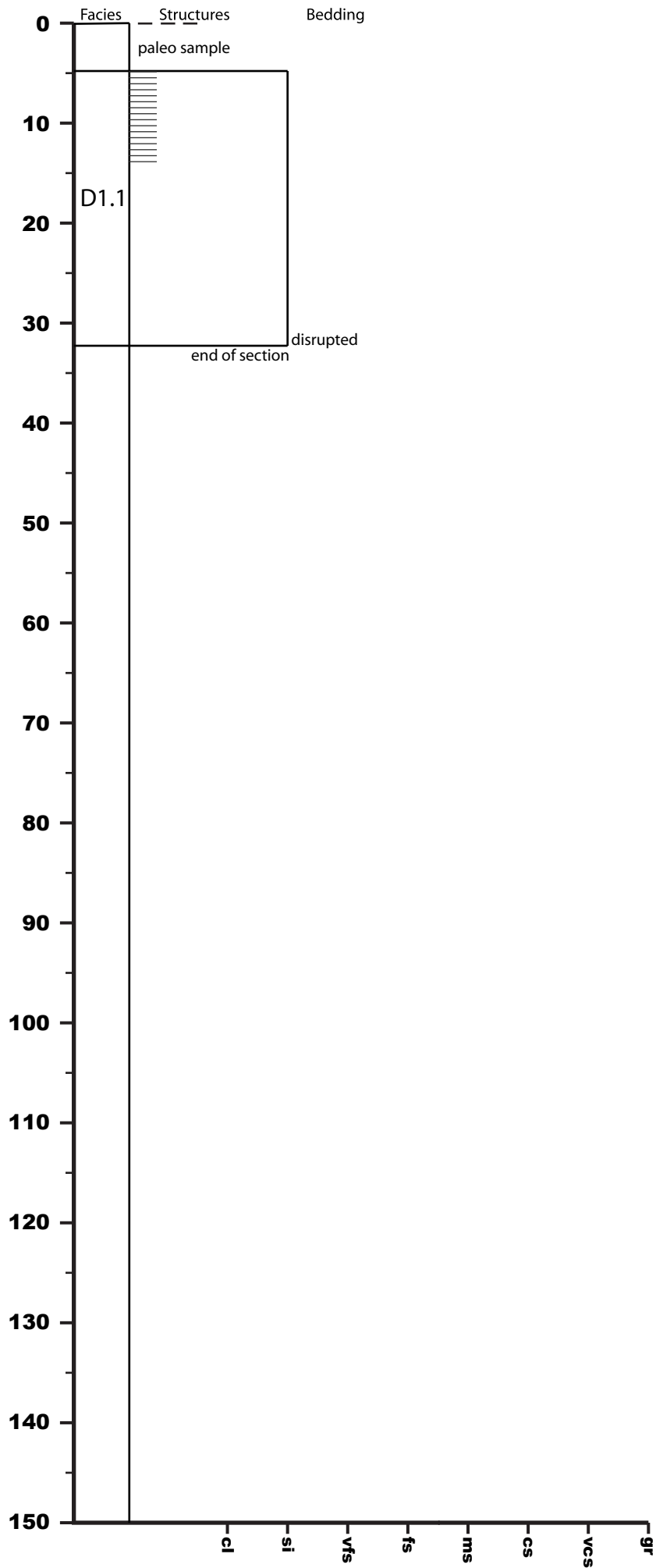

U1438E-25R-1

1070.8 - 1072.07 mbsf

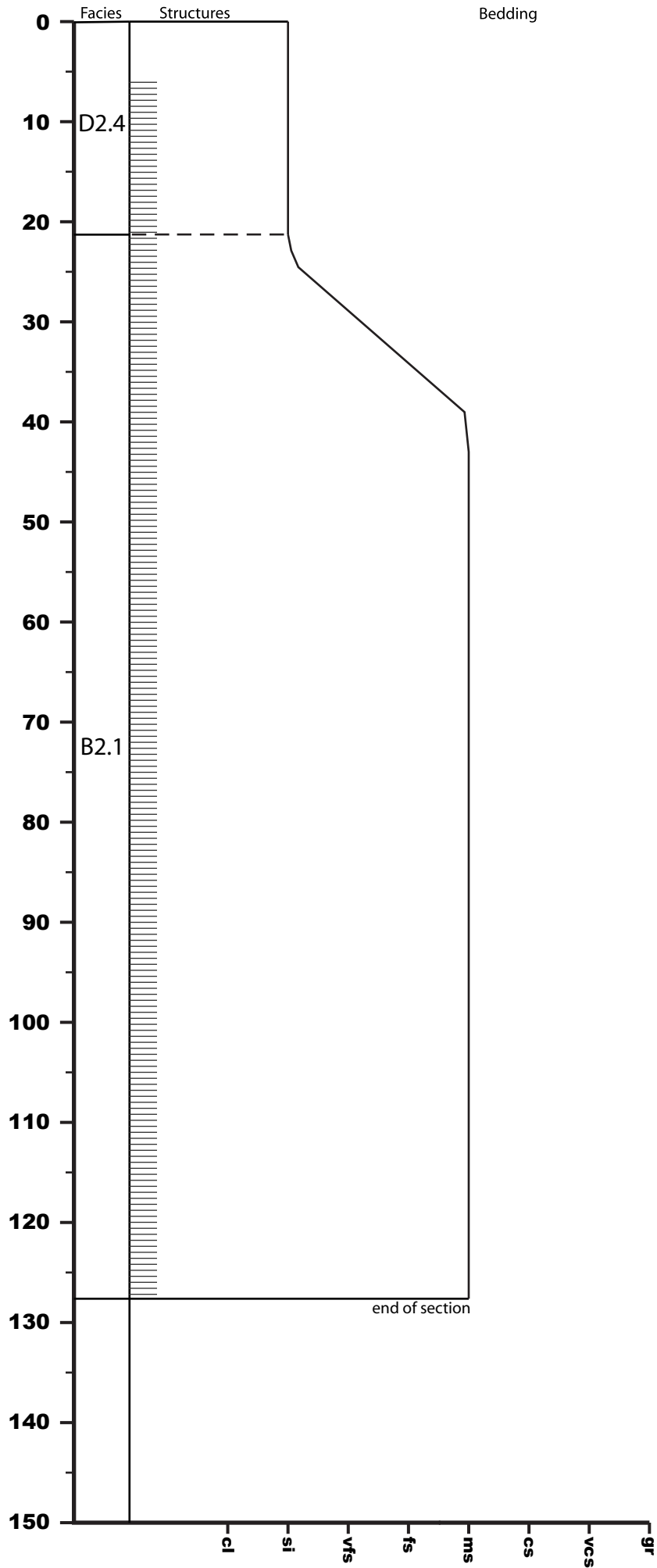

U1438E-25R-2

1072.07 - 1073.46 mbsf

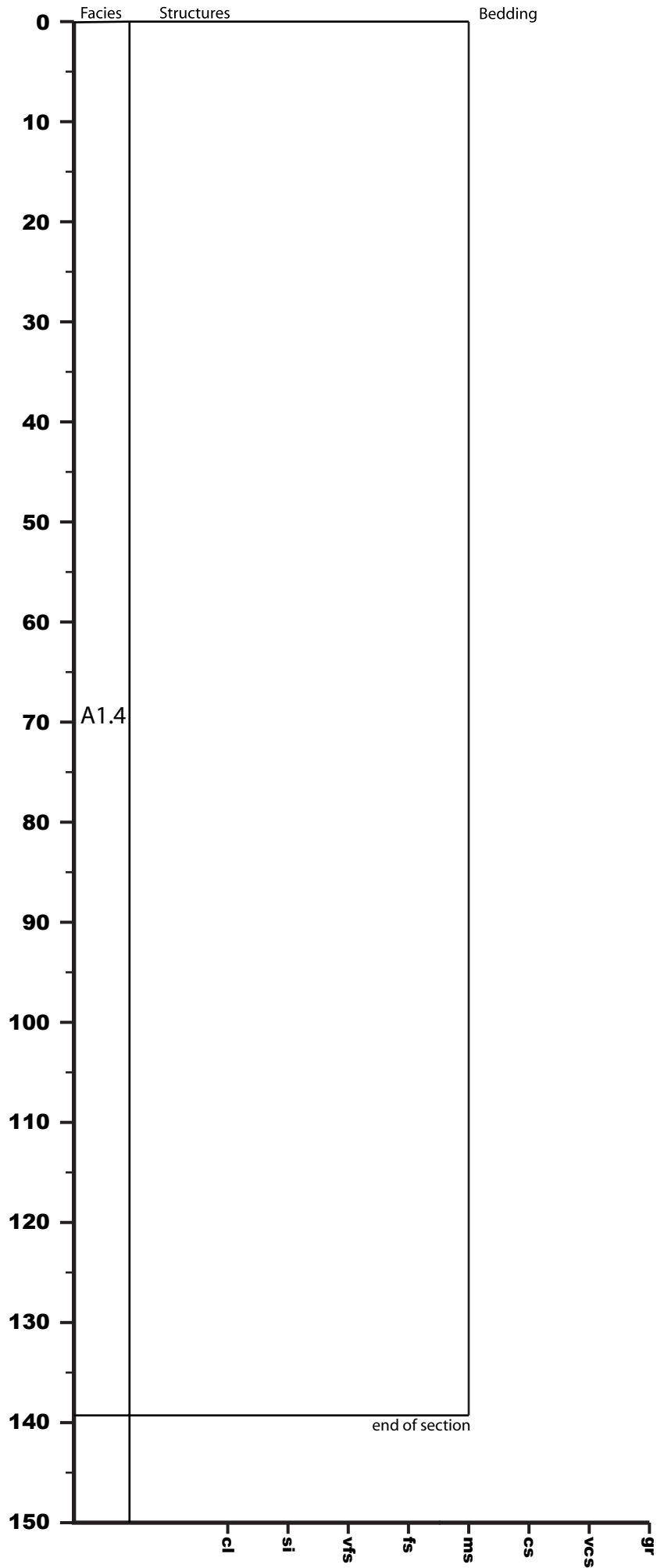

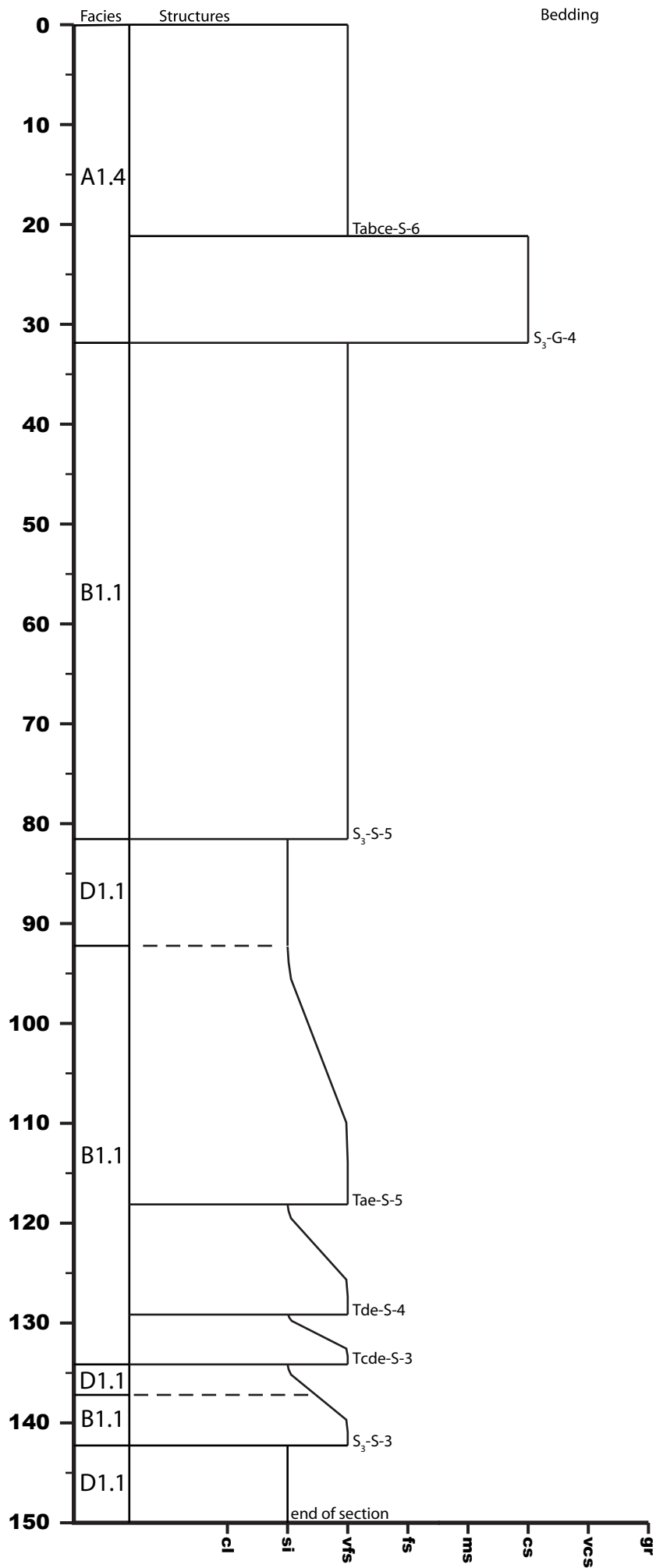

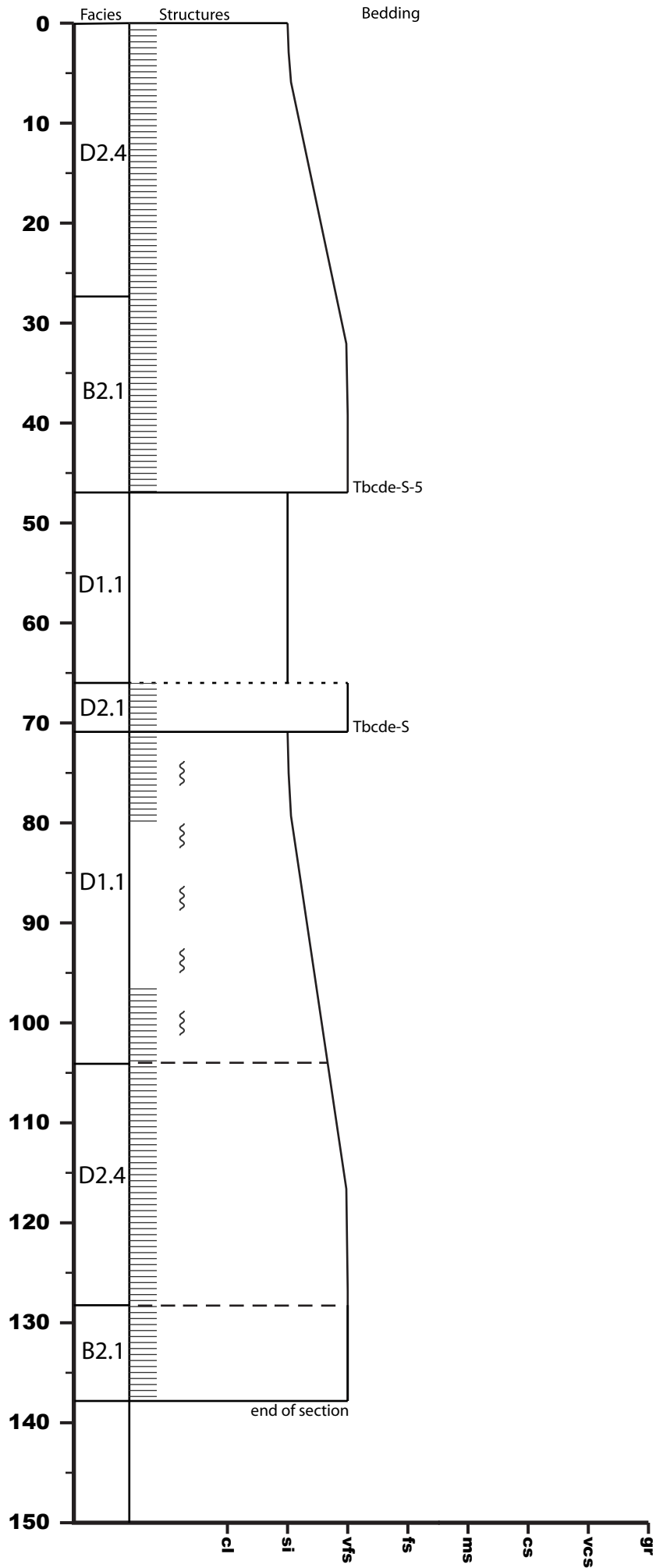

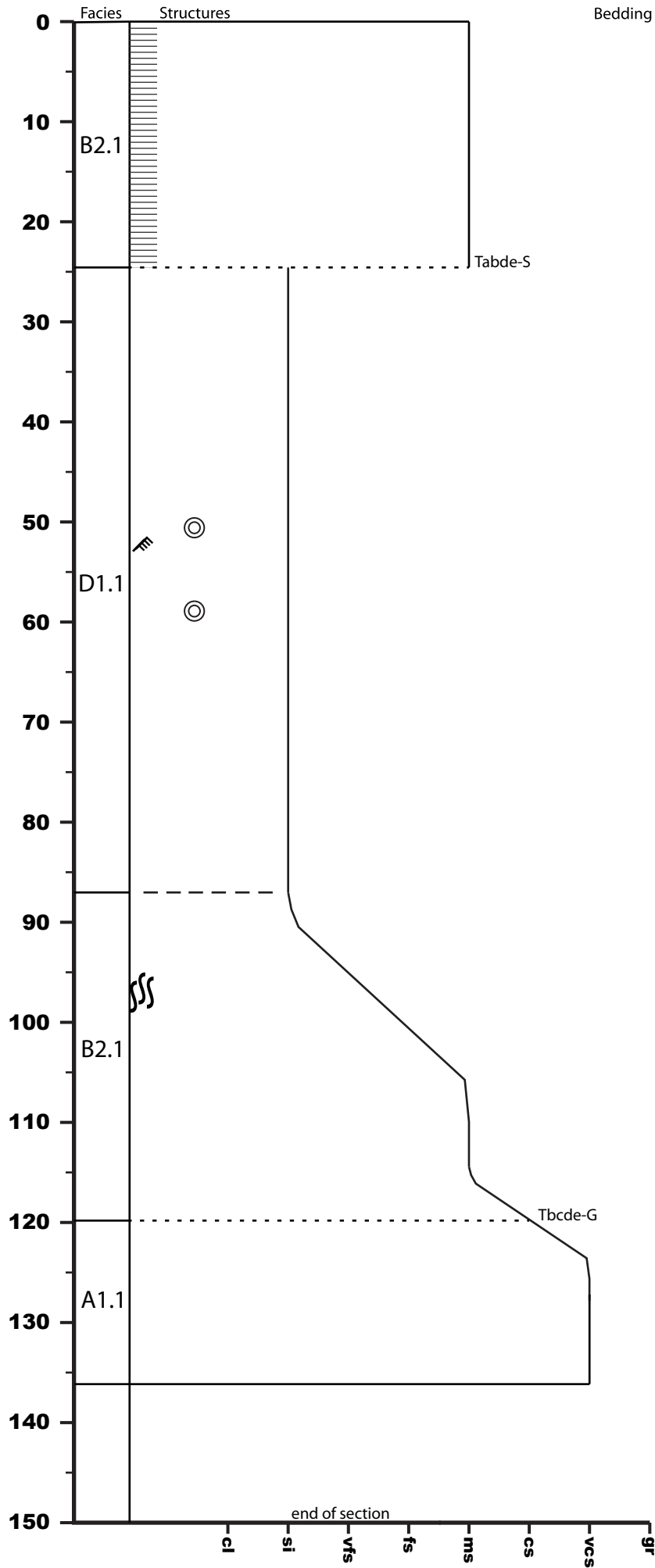



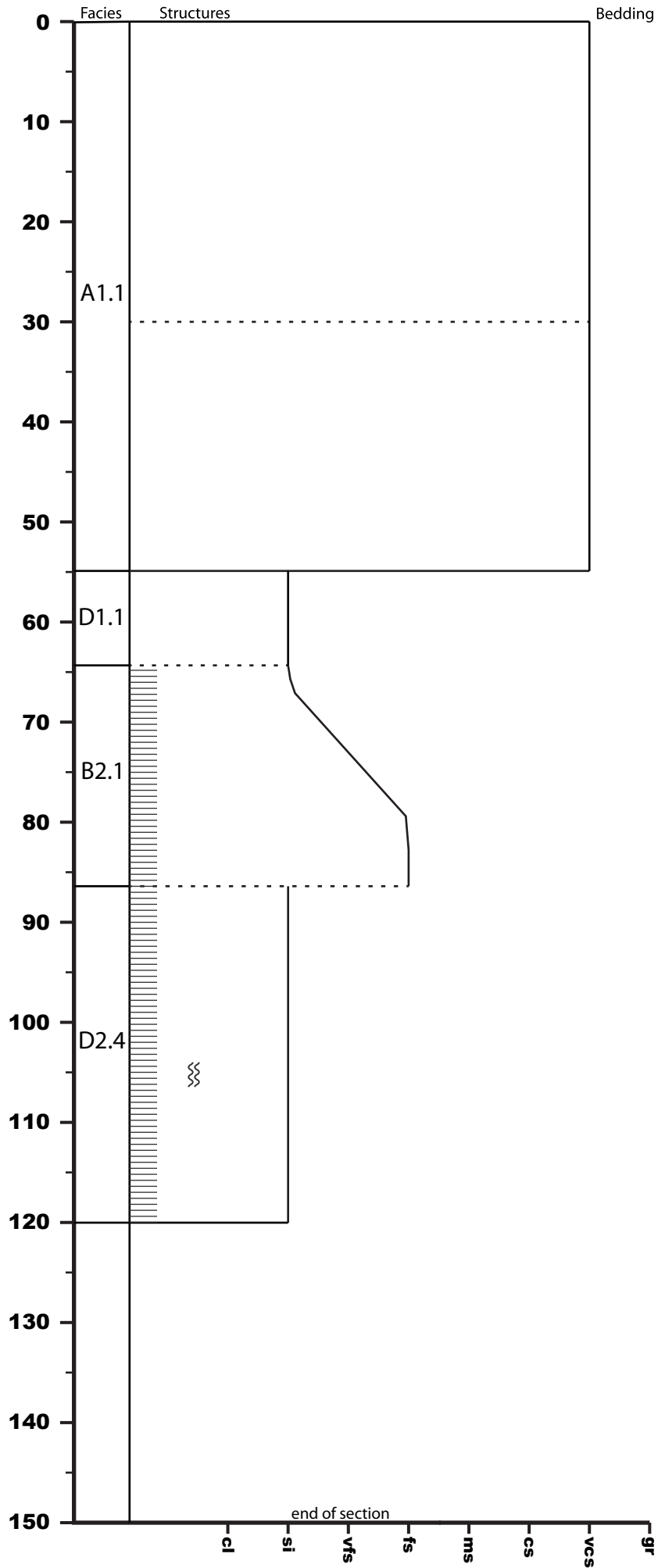

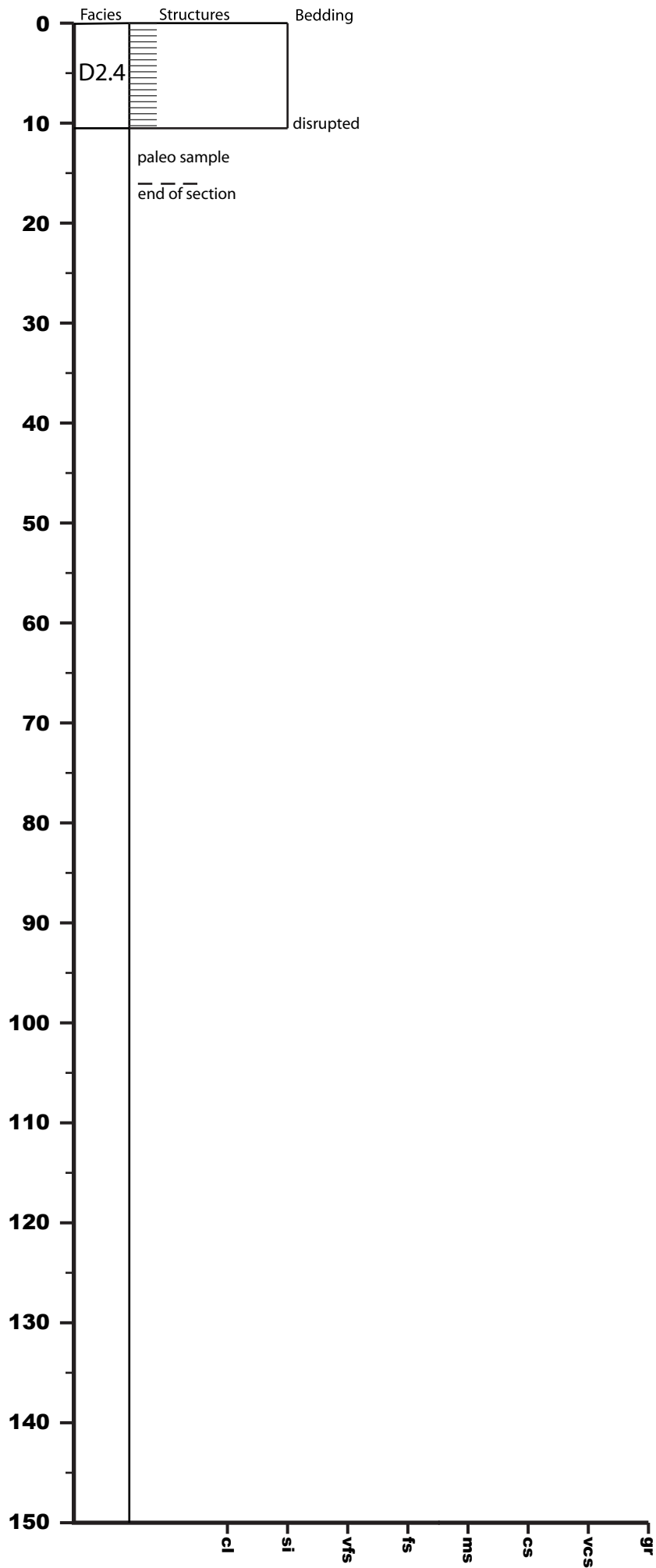

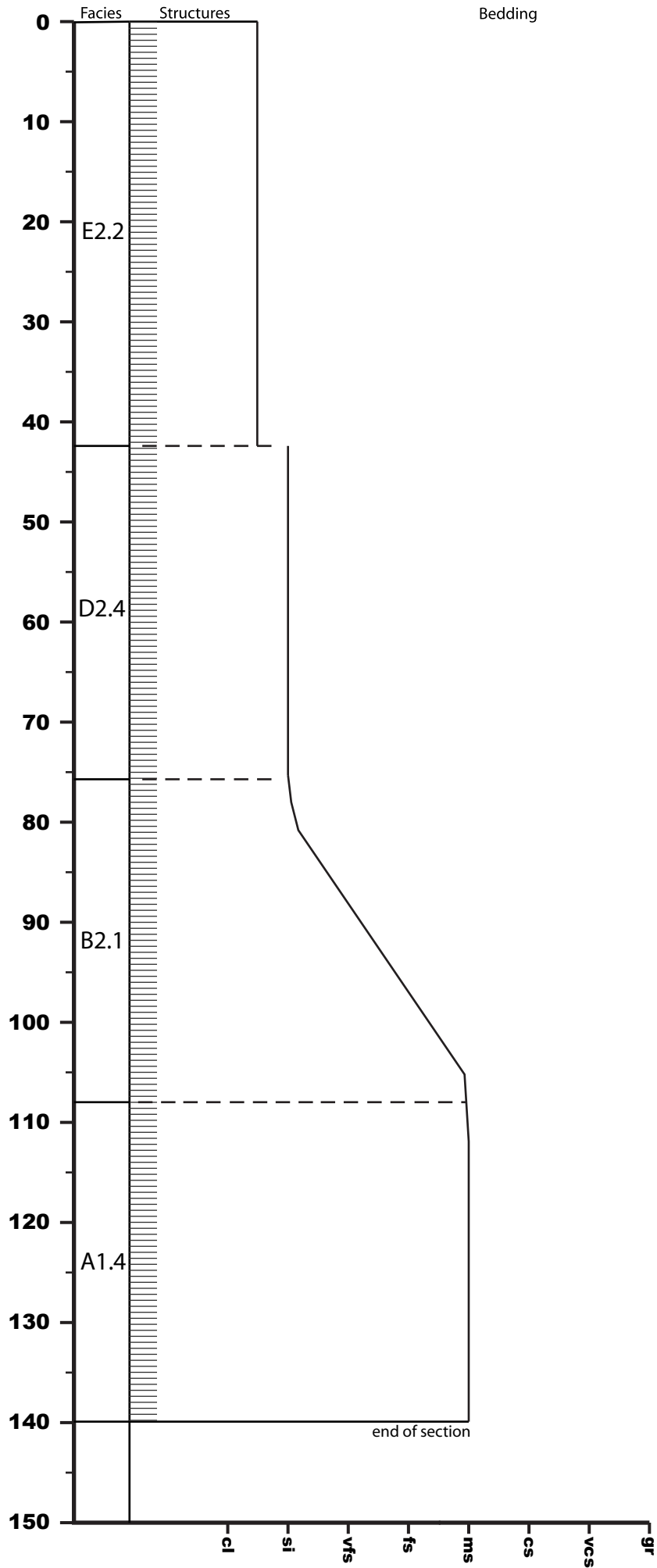

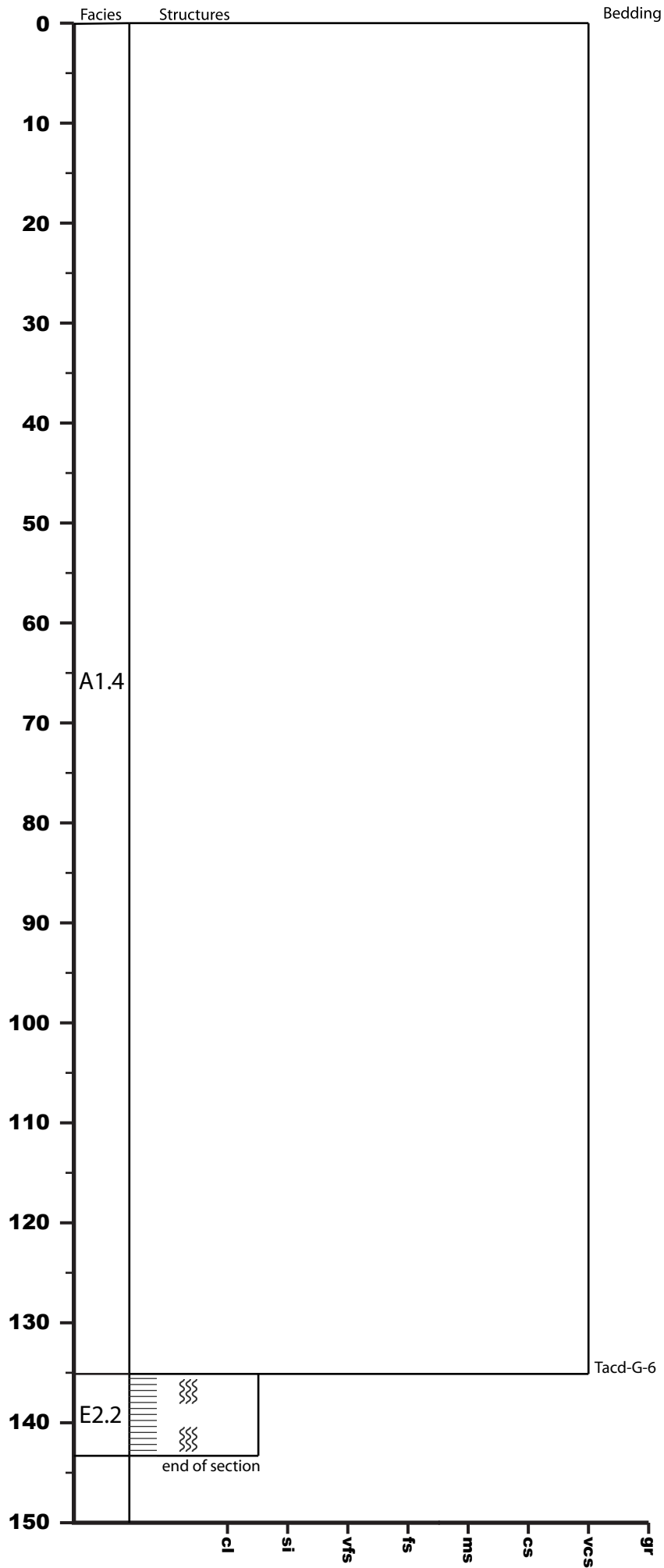

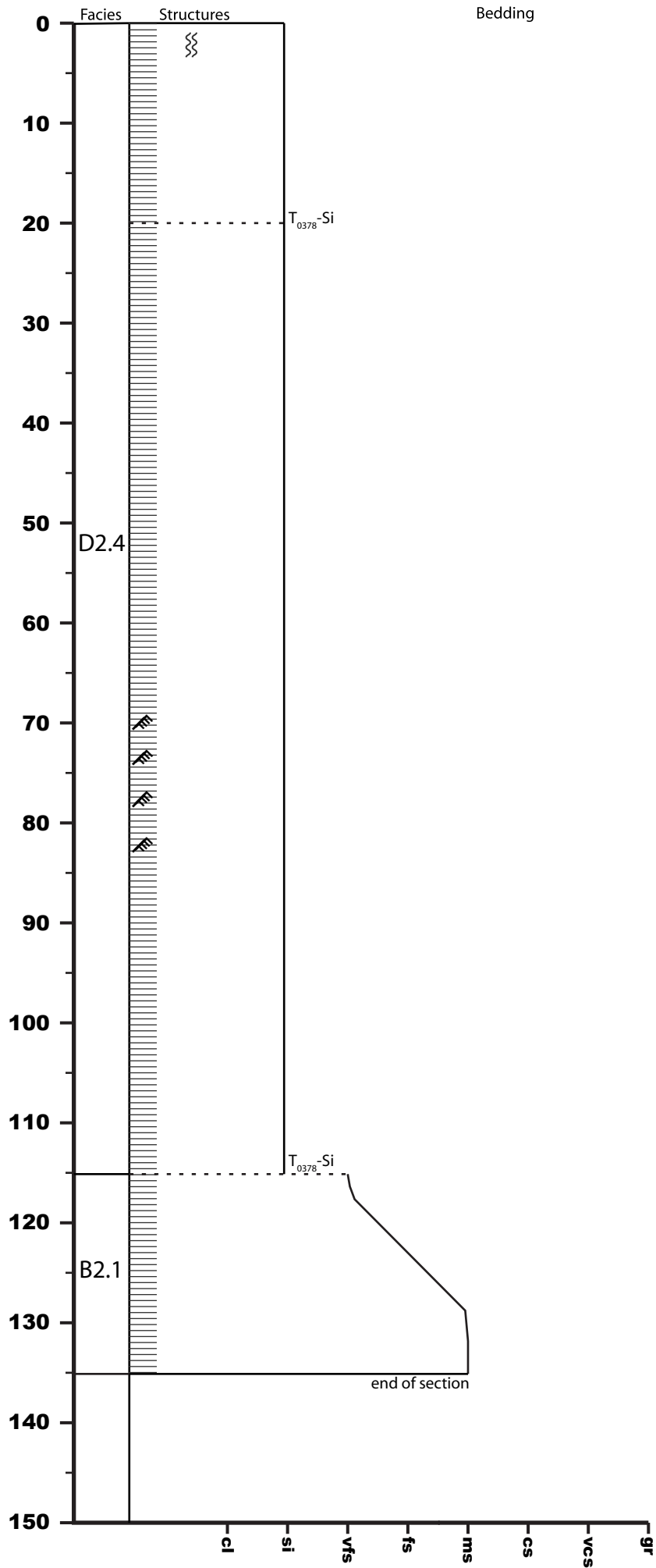

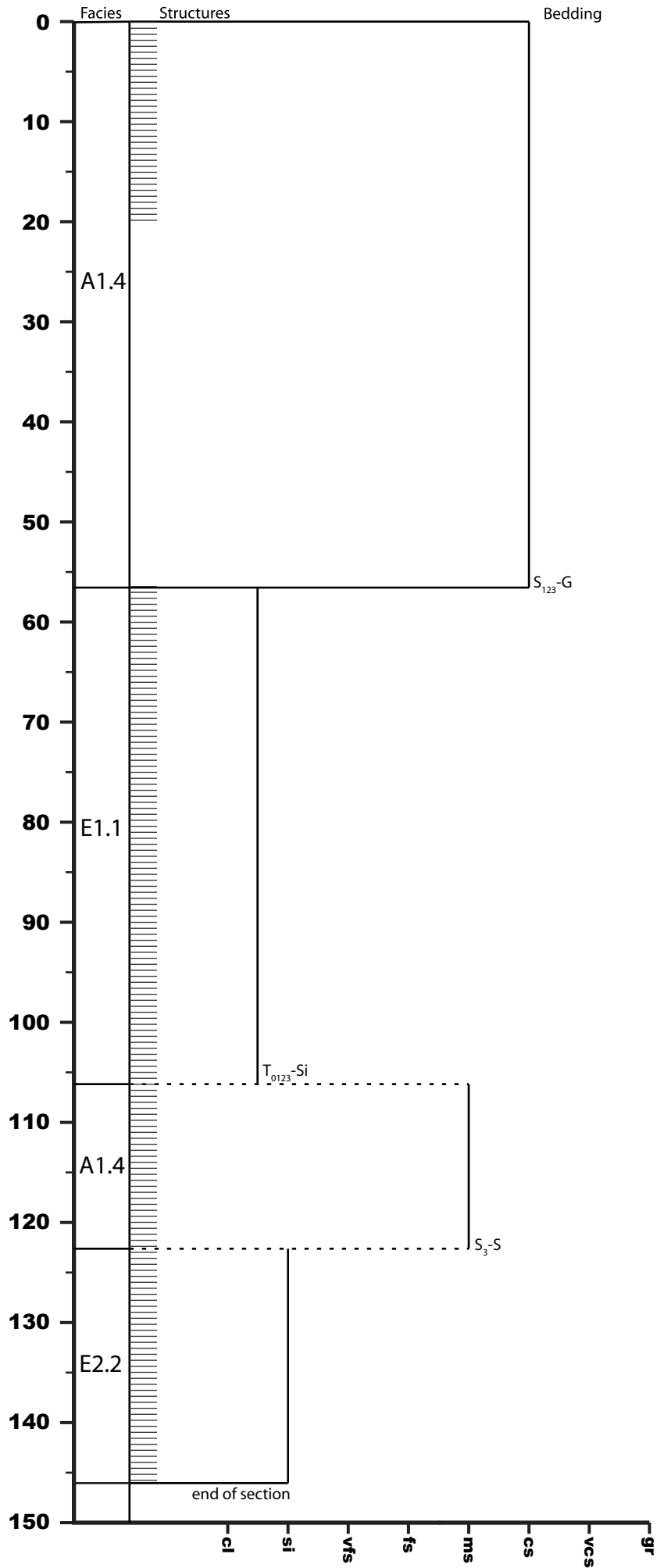

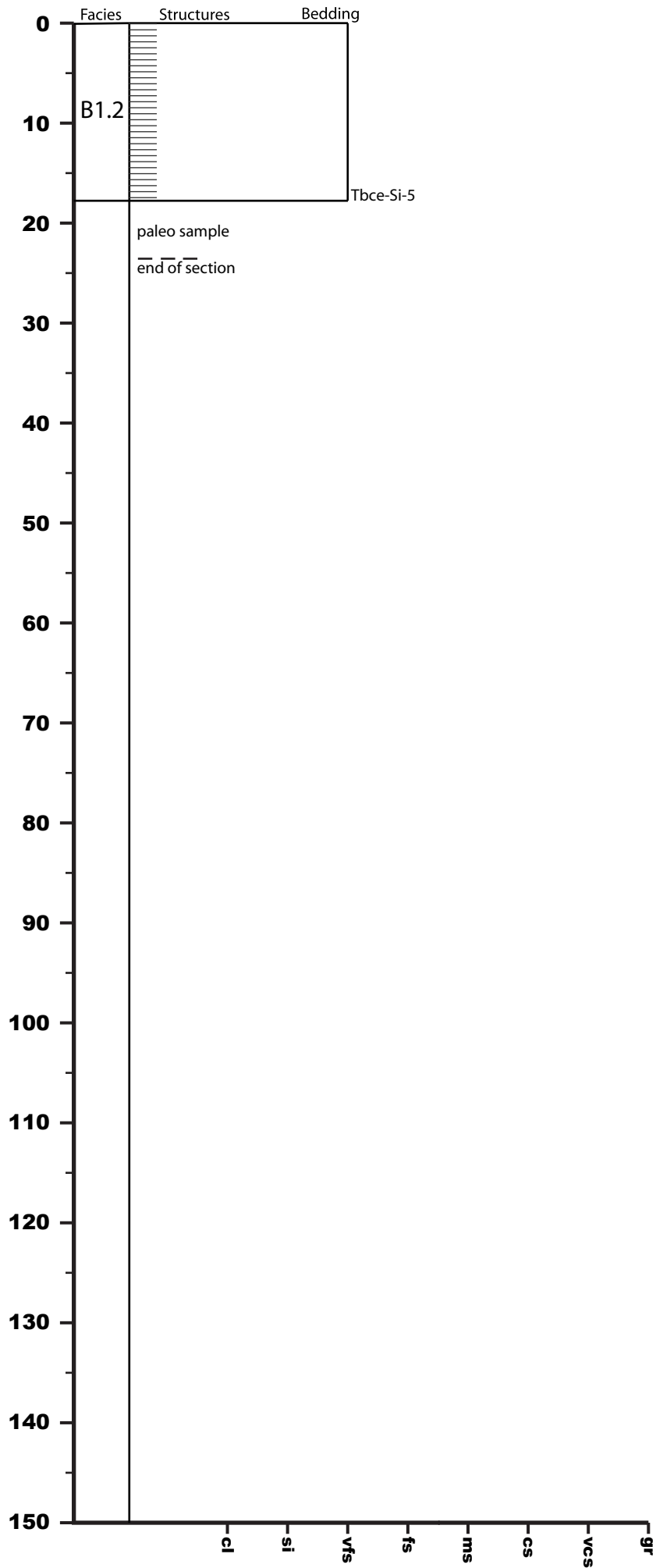

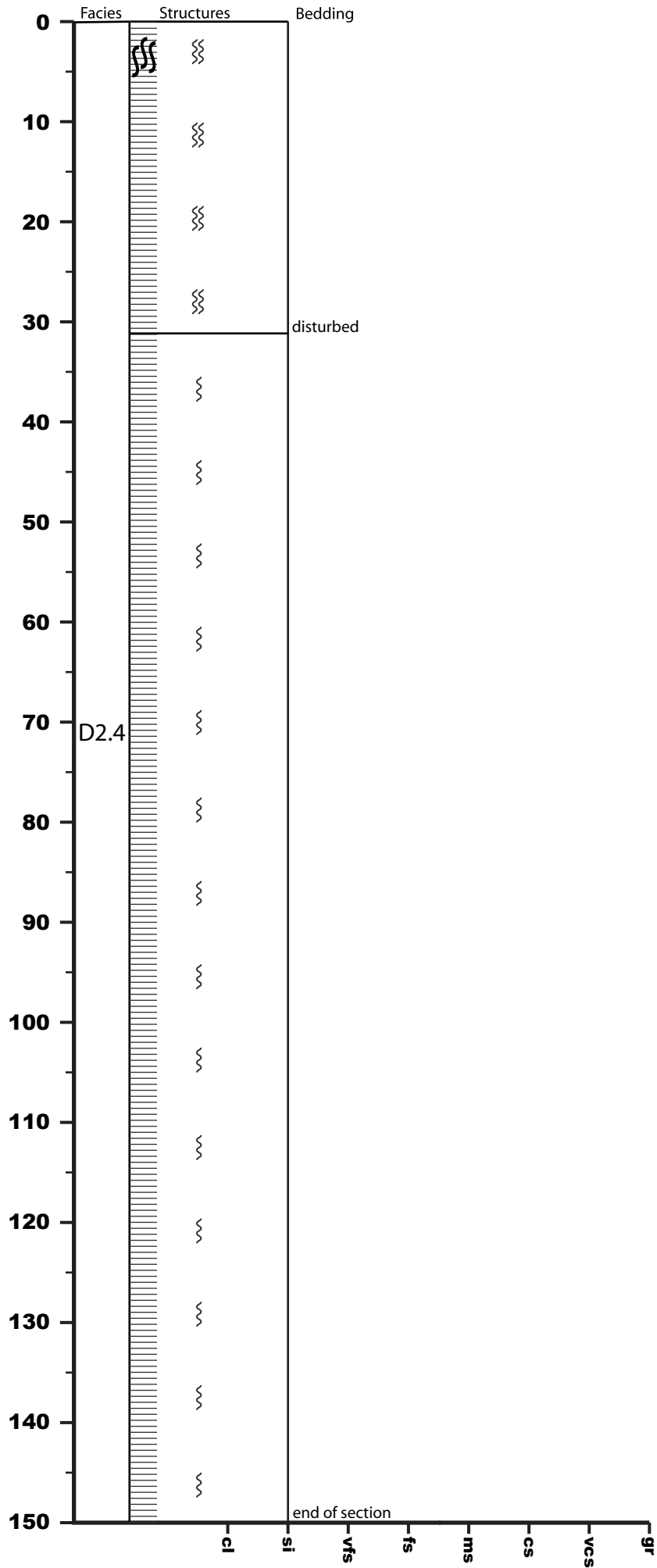



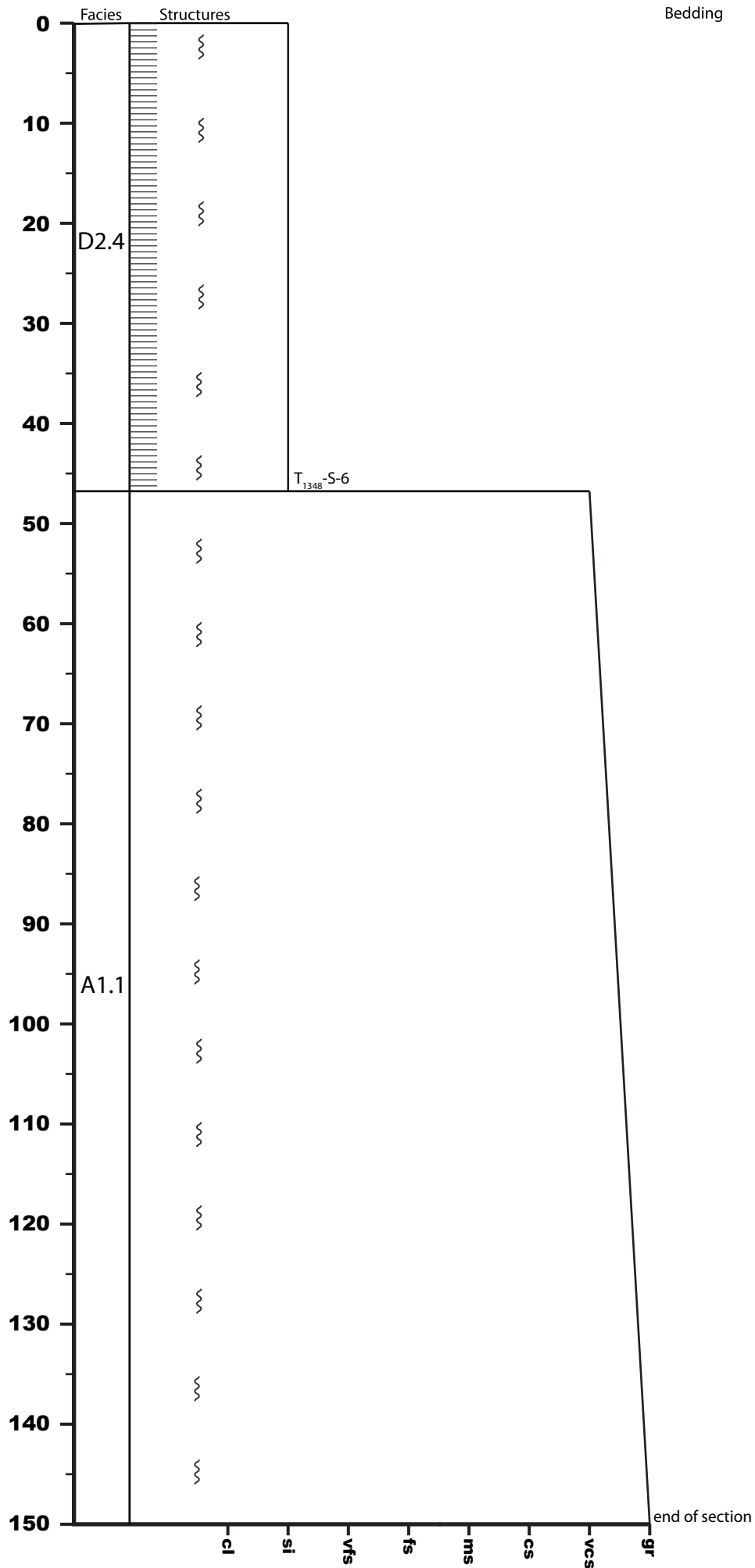

U1438E-27R-3

1093.15 - 1094.55 mbsf

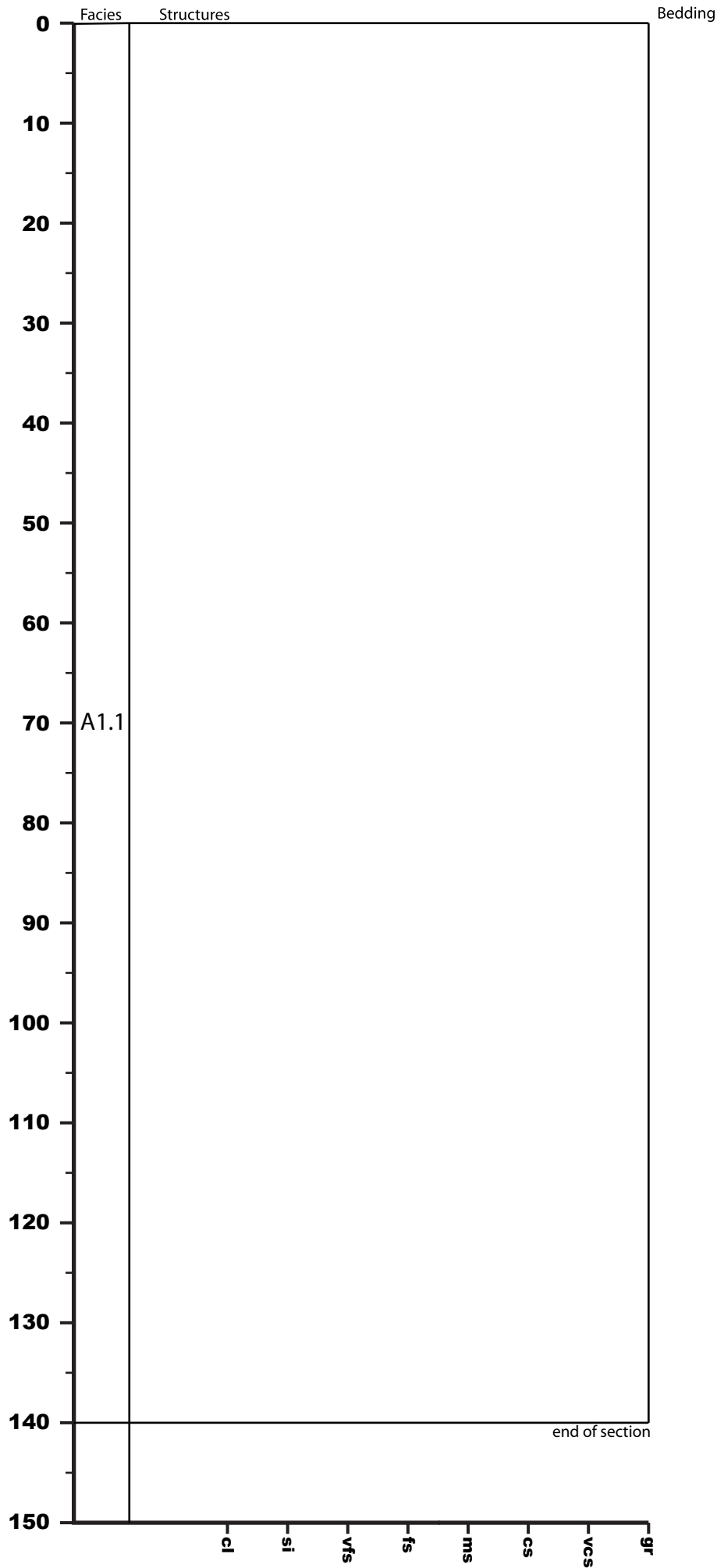

U1438E-27R-4

1094.55 - 1095.89 mbsf

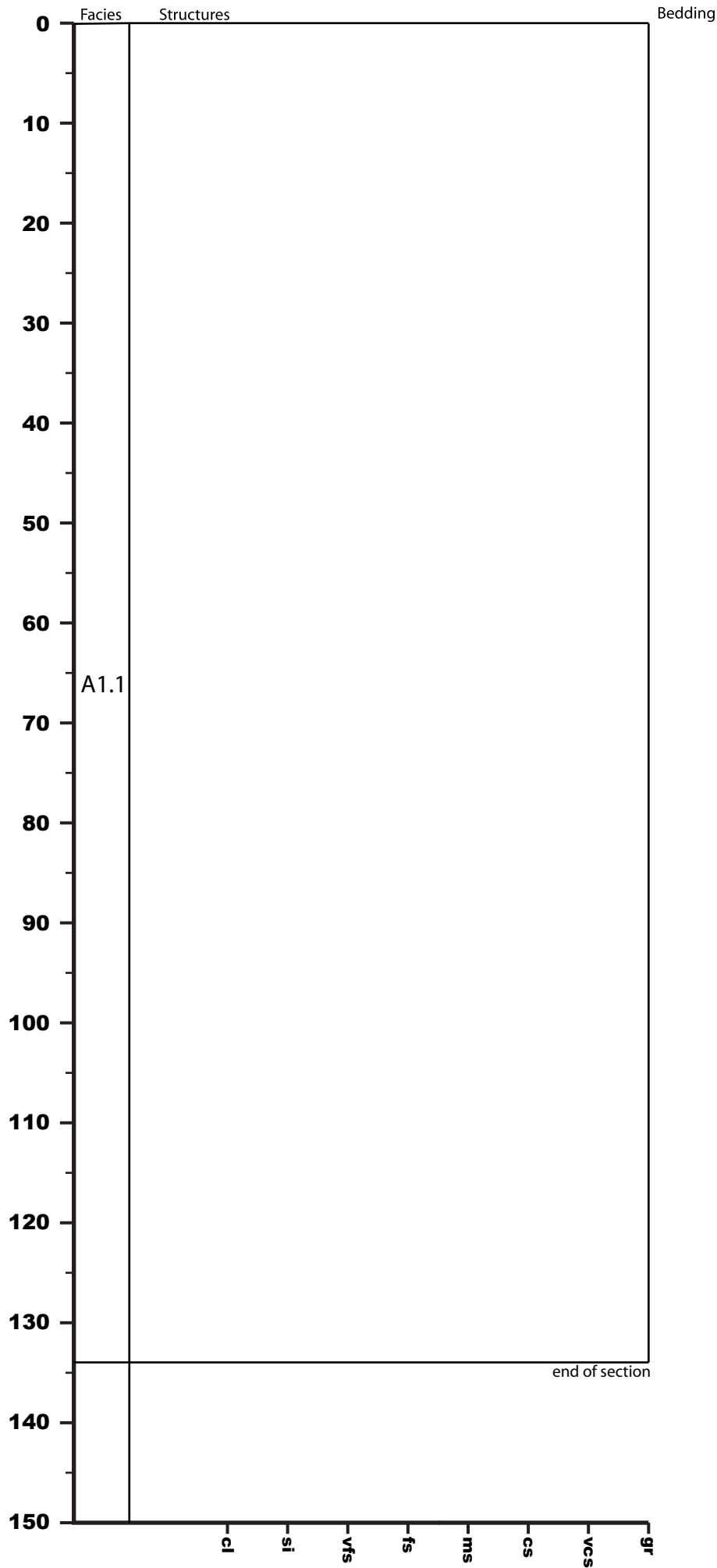

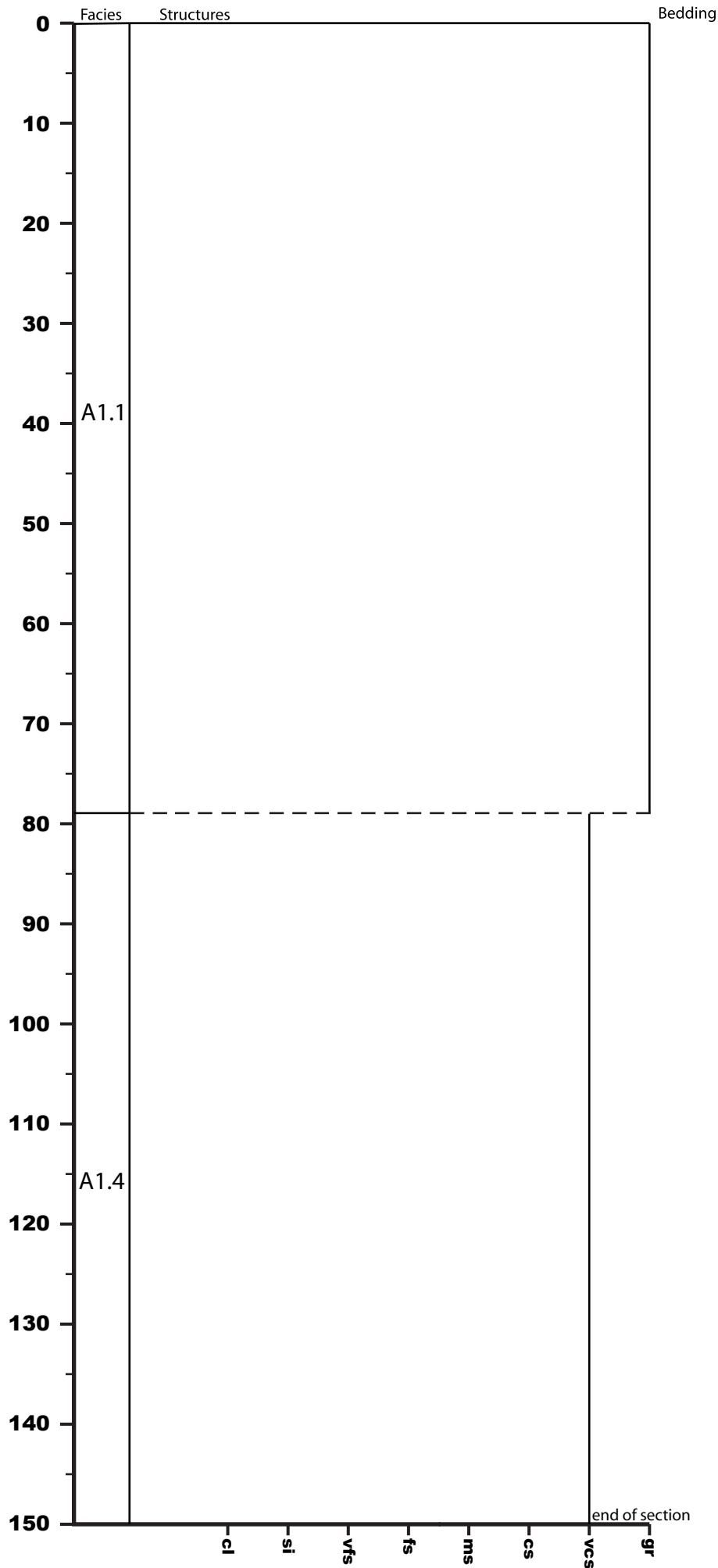

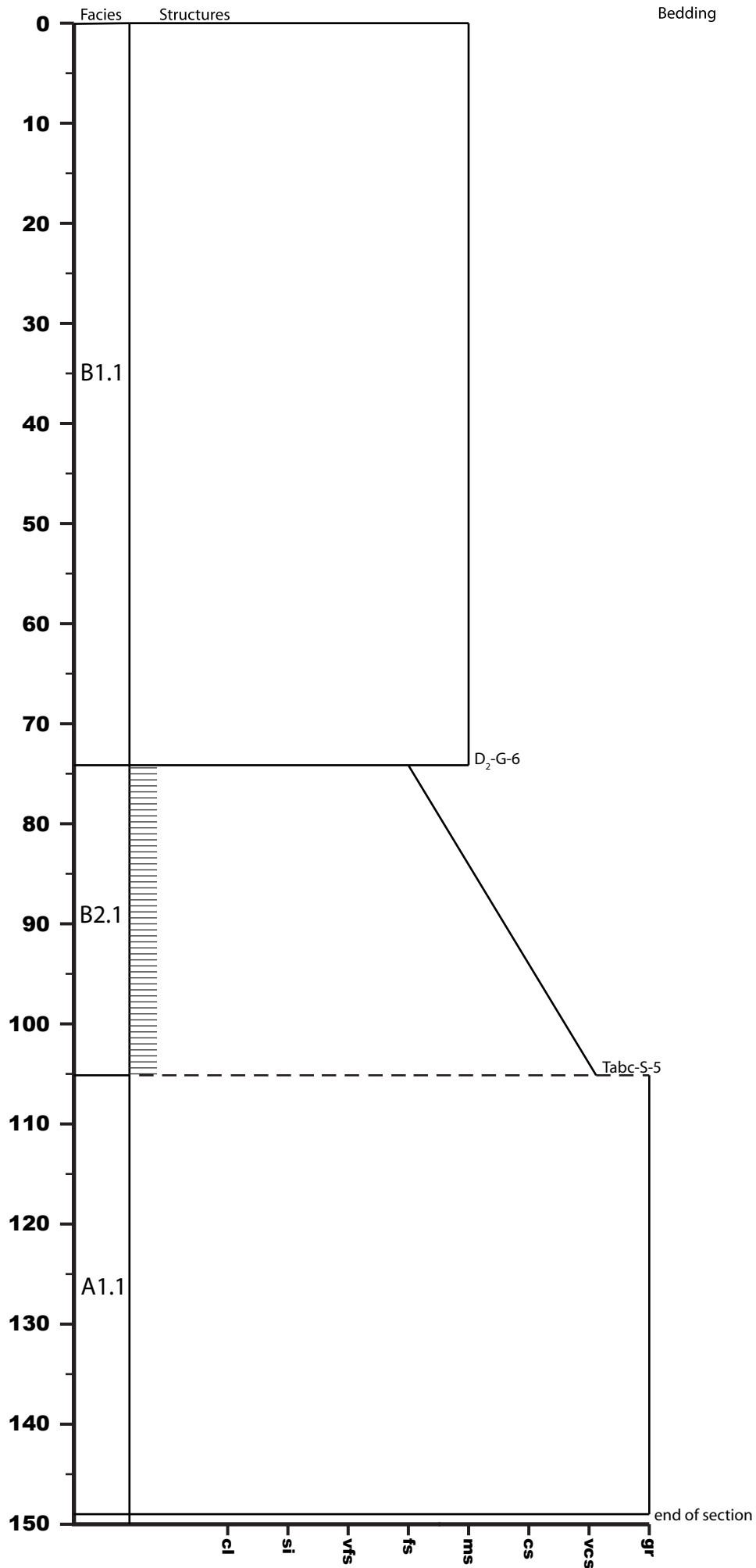

U1438E-27R-7

1098.88 - 1099.67 mbsf

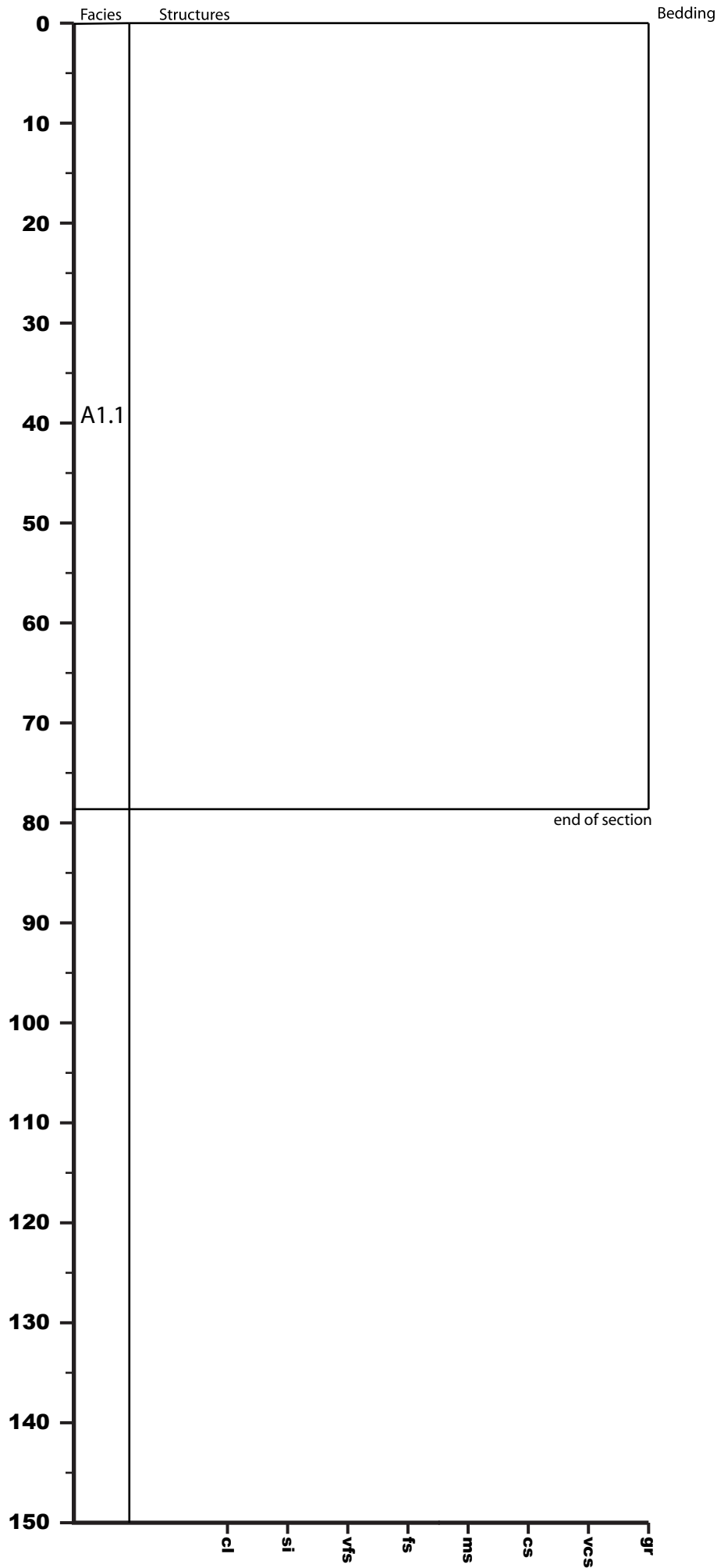

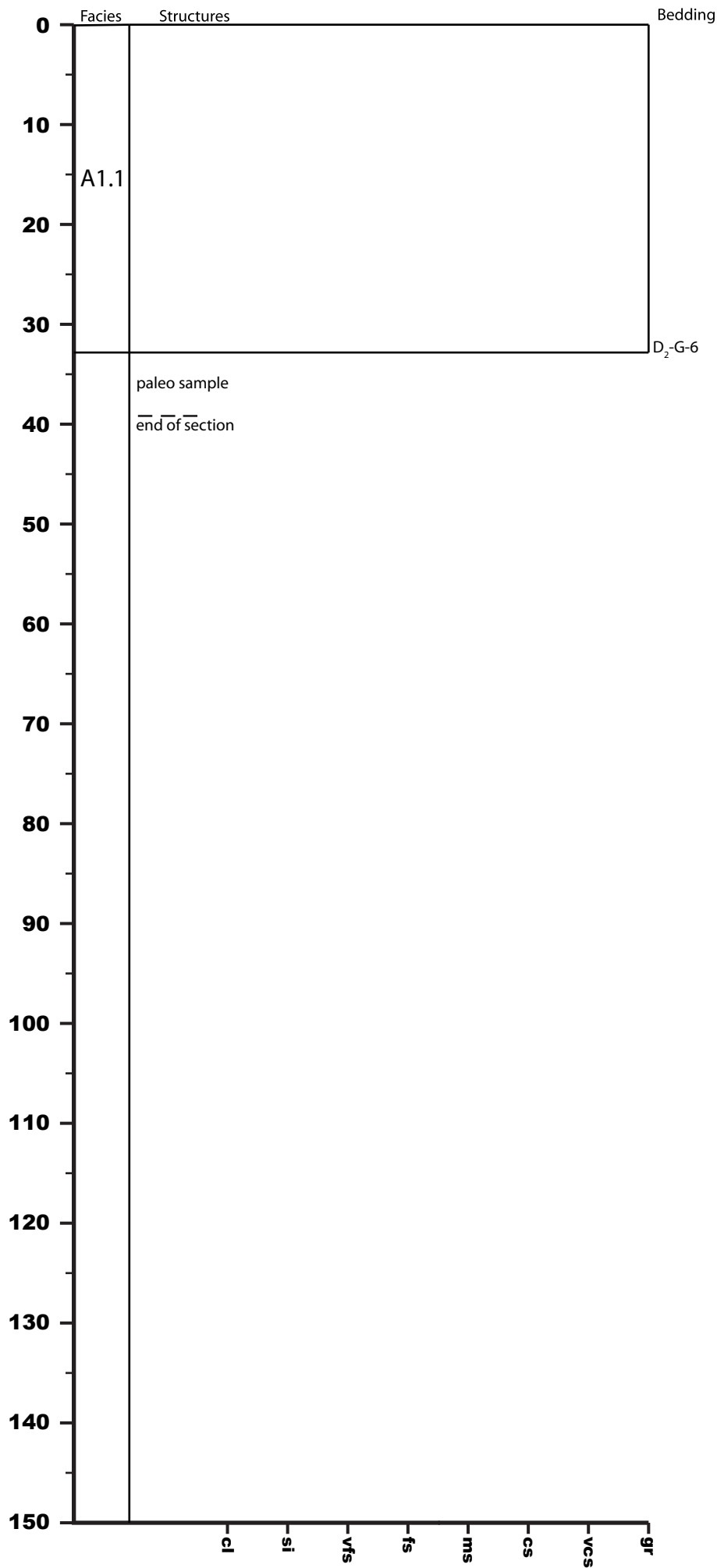

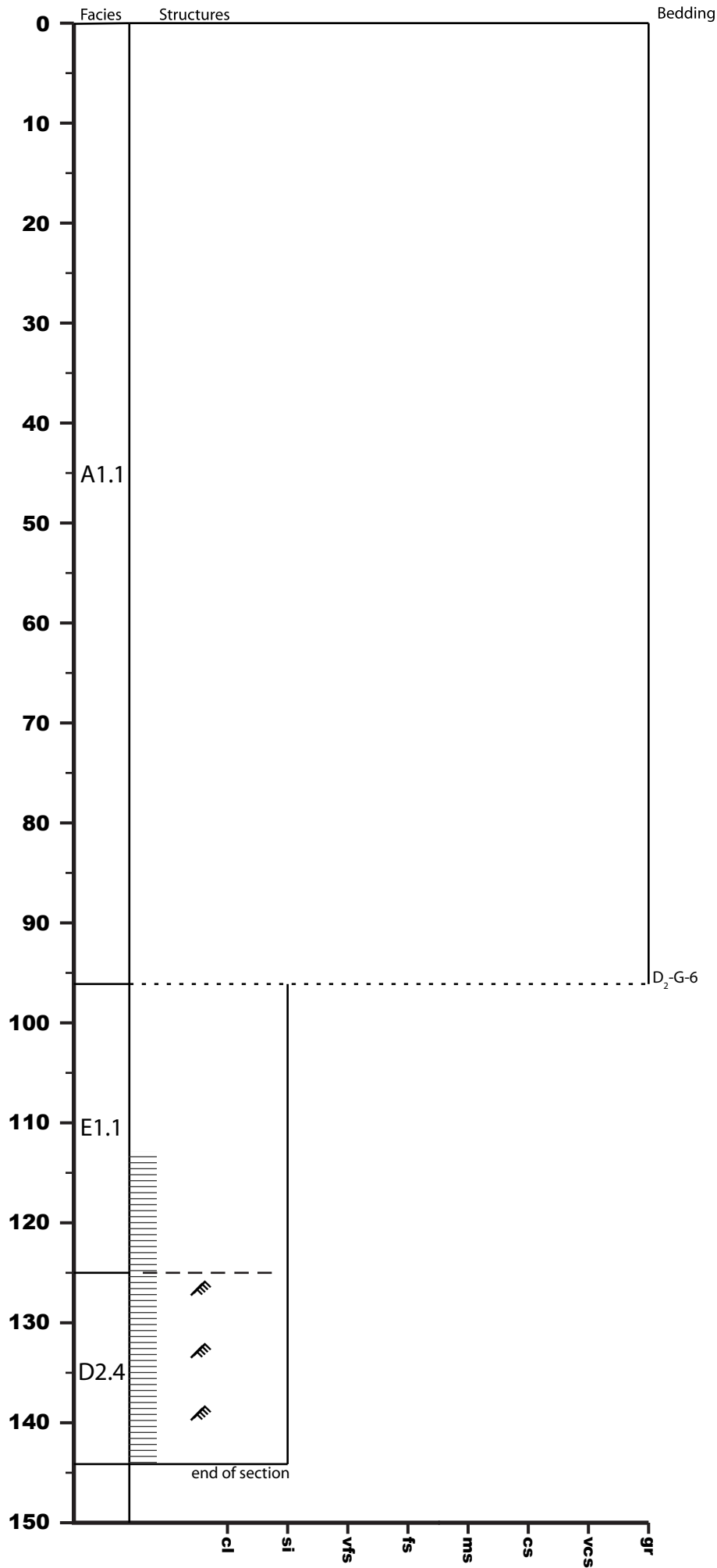



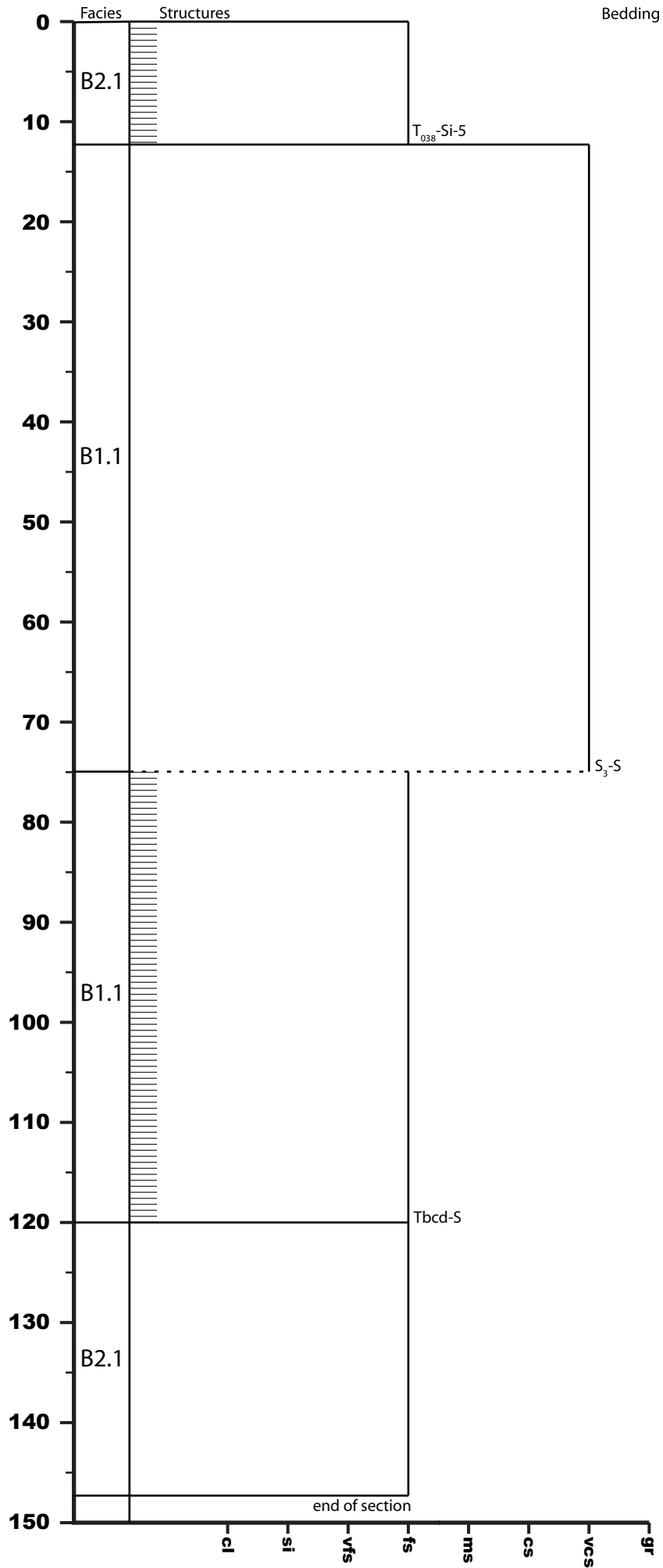

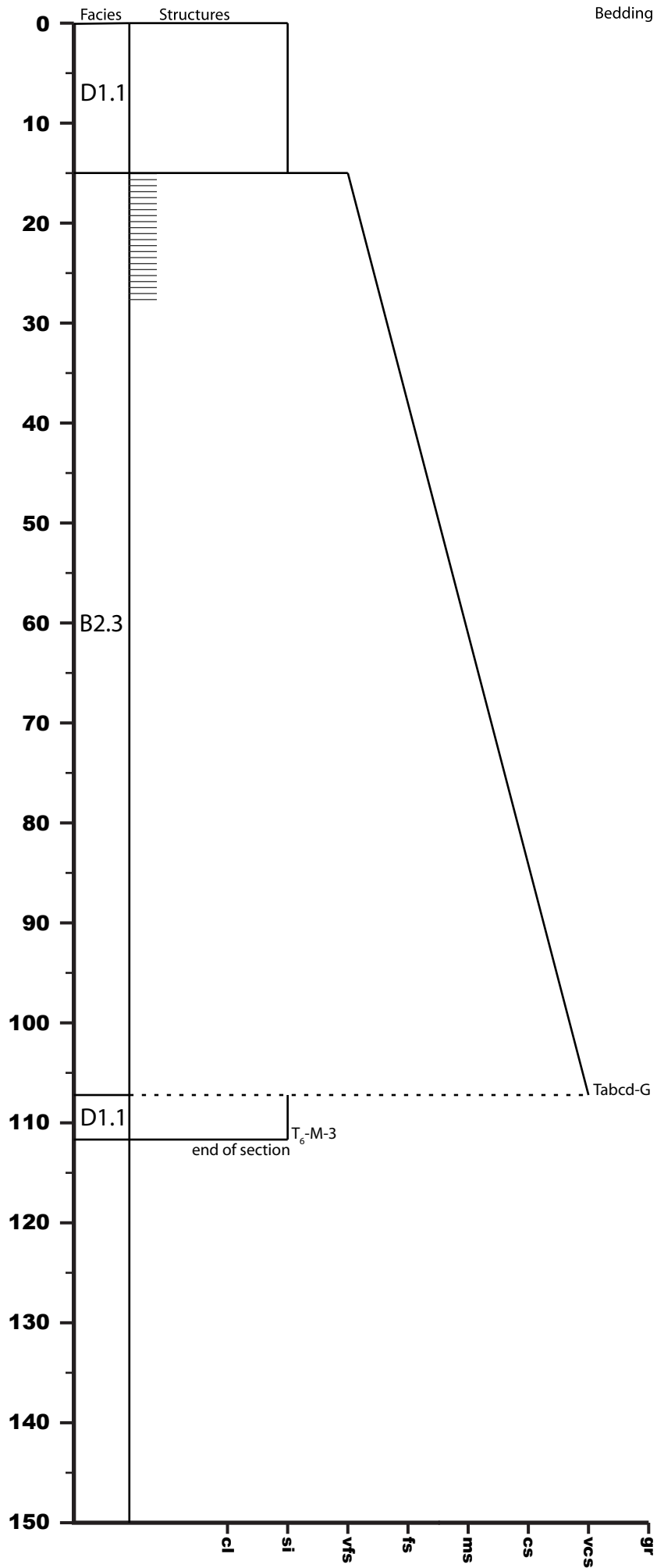

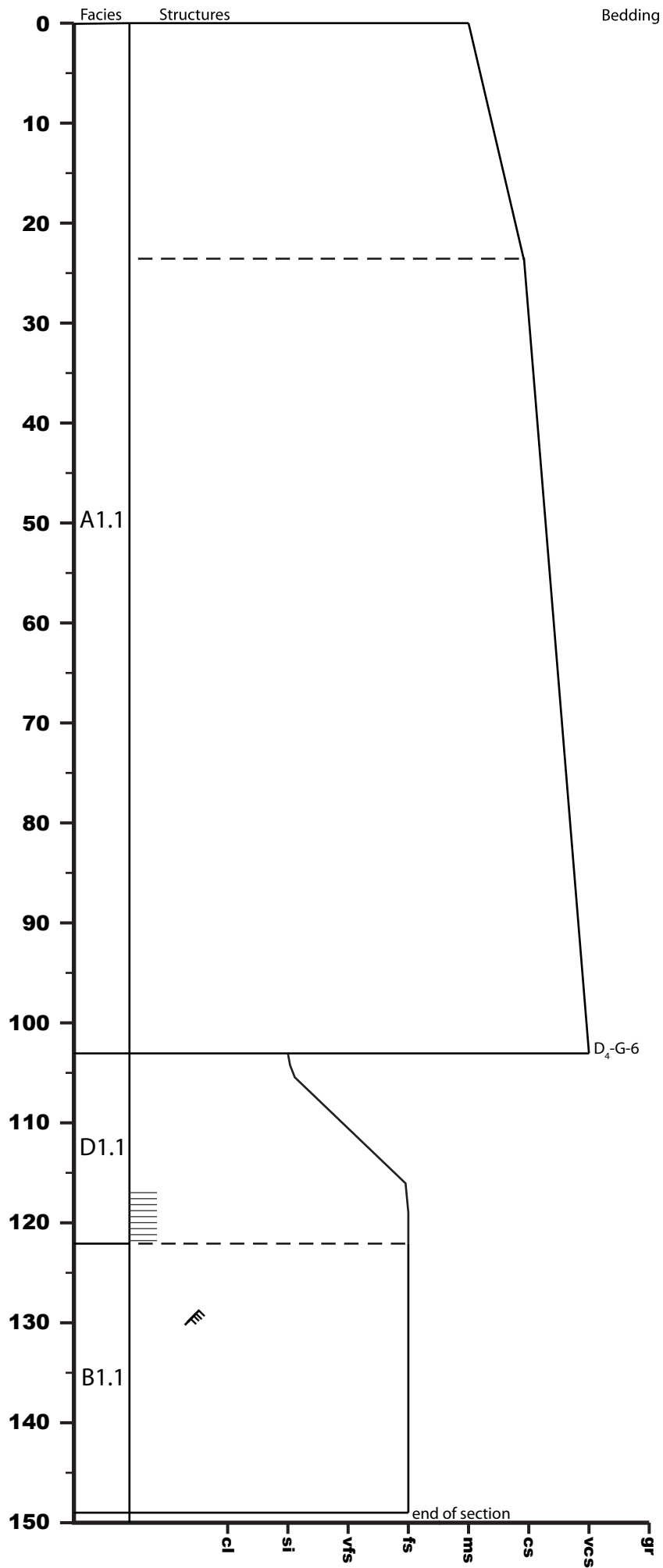

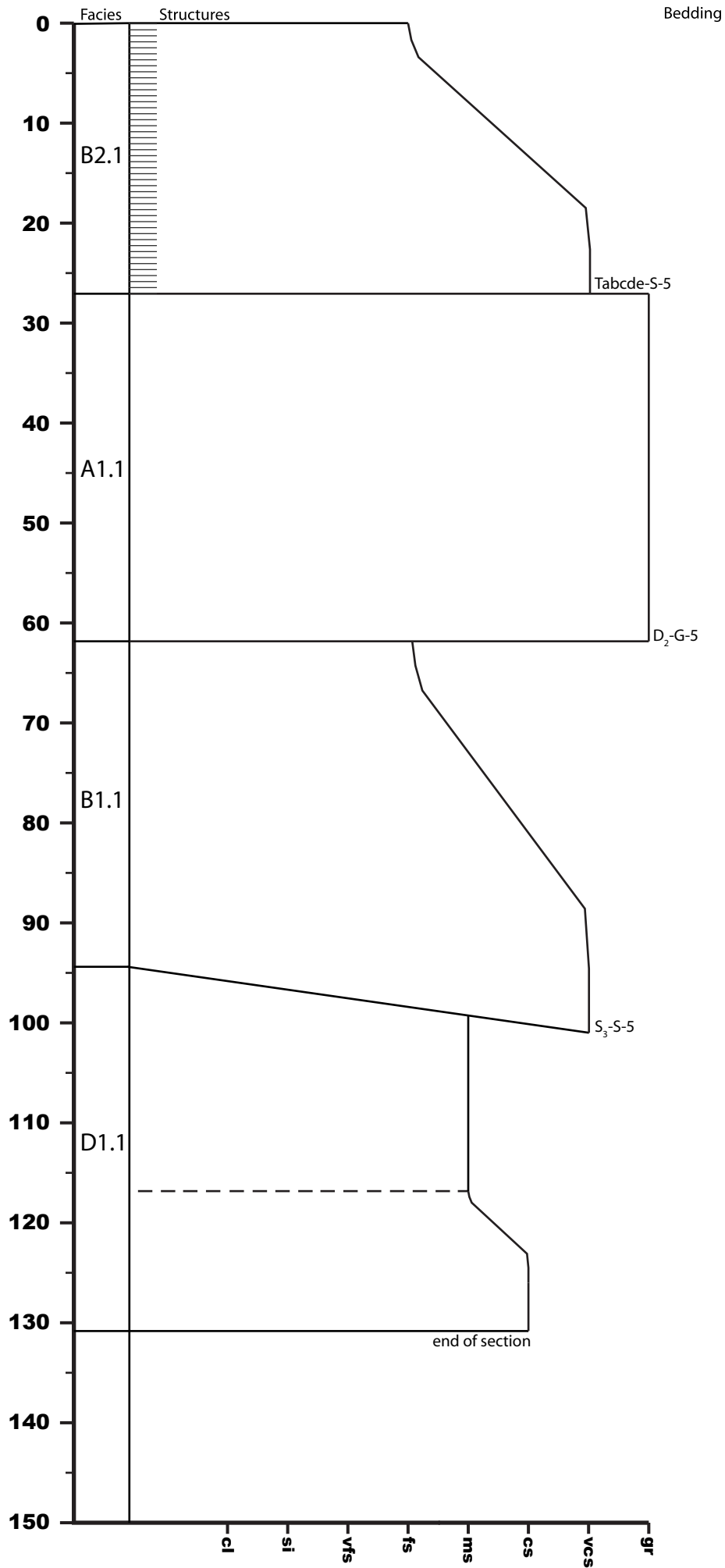

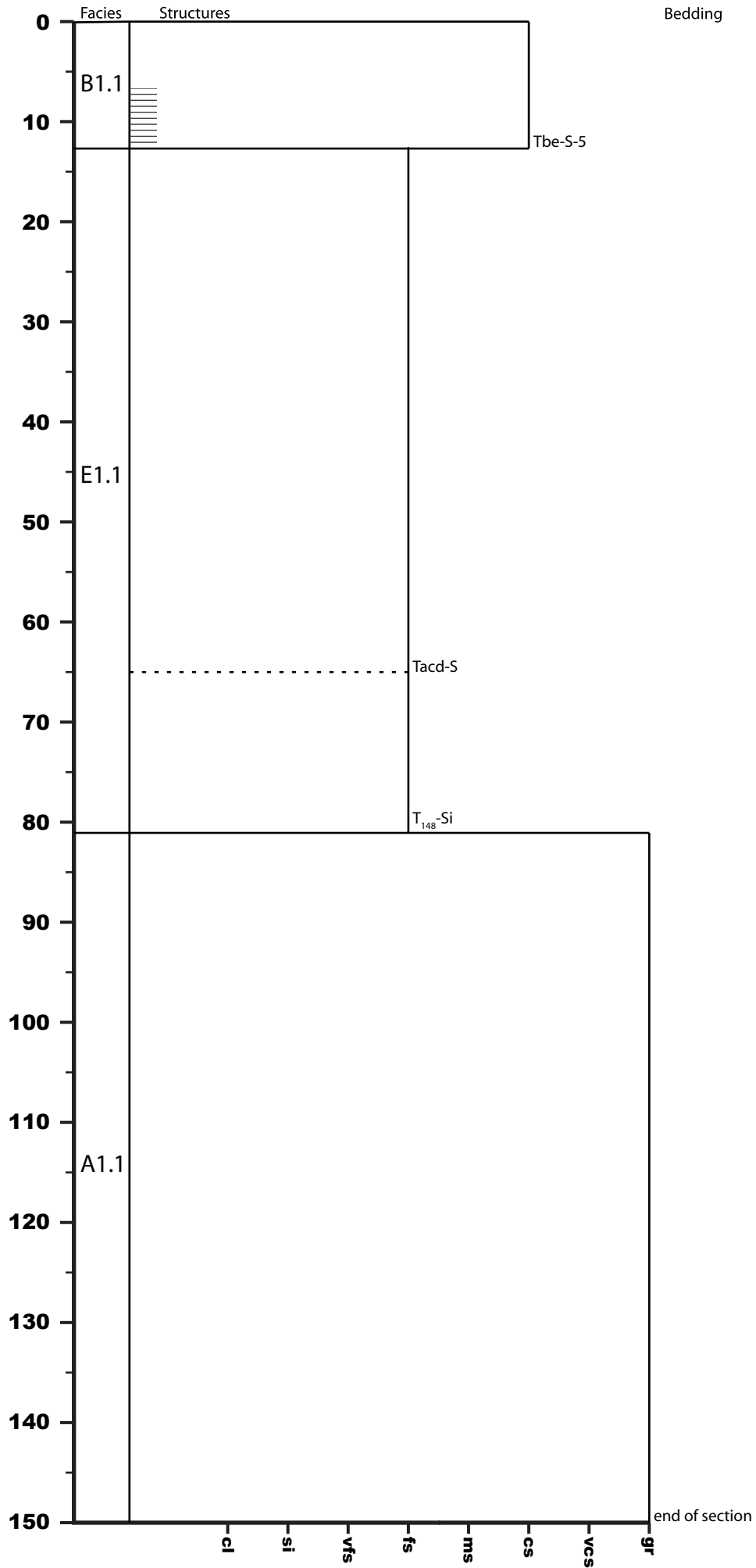

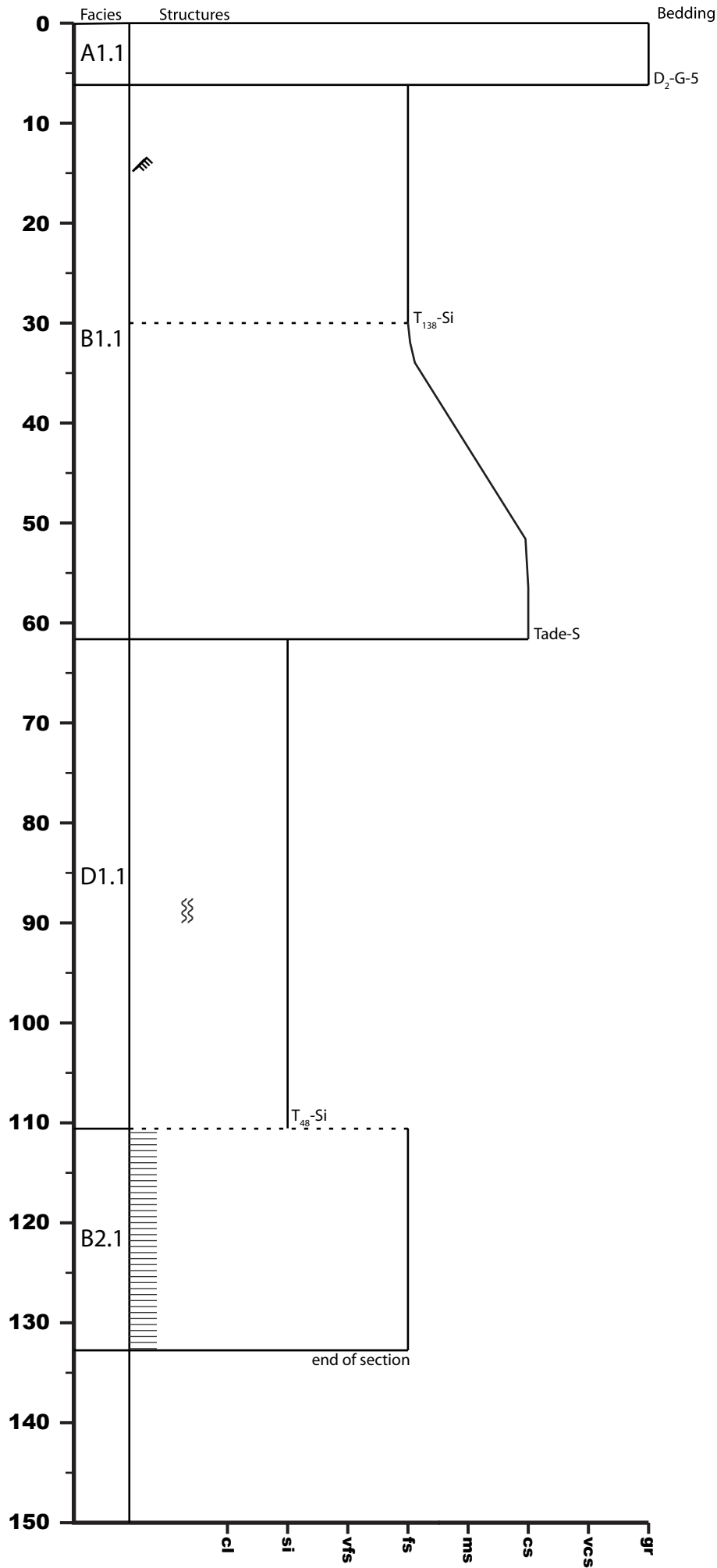

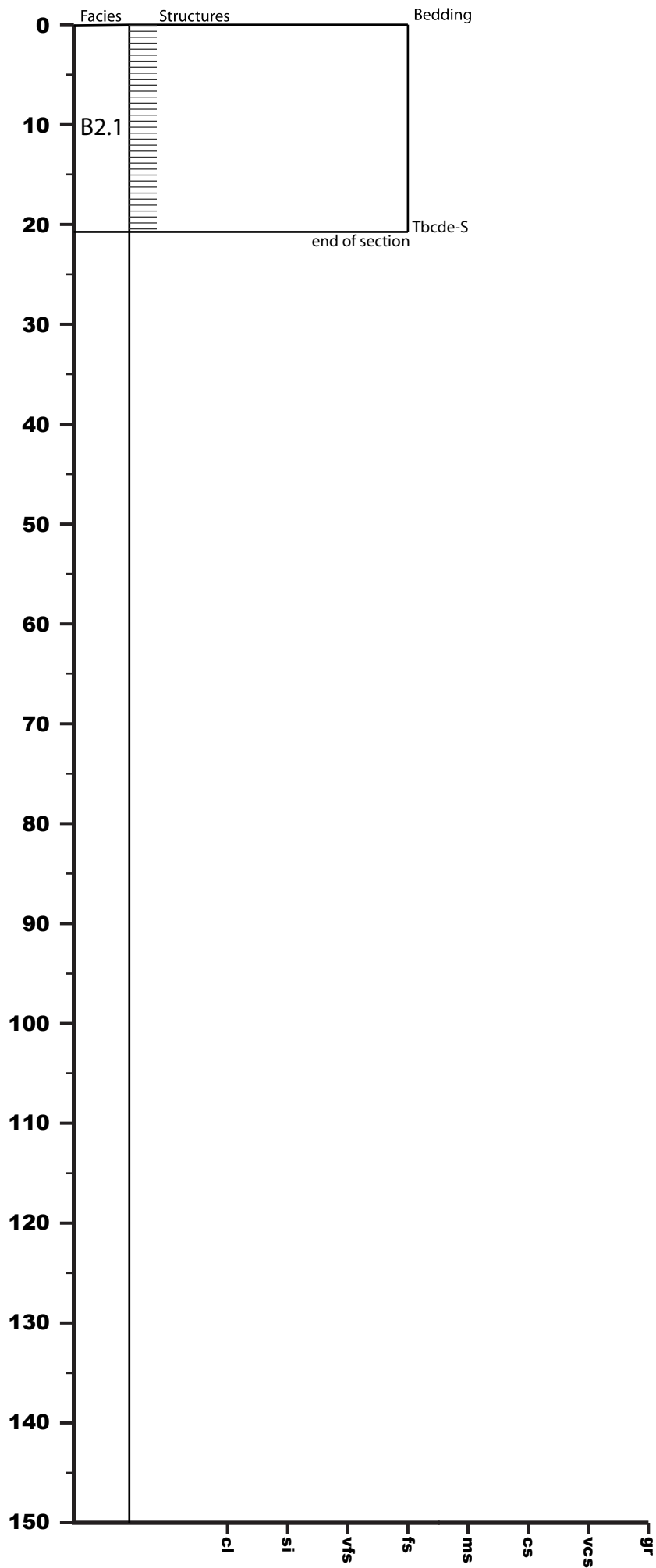

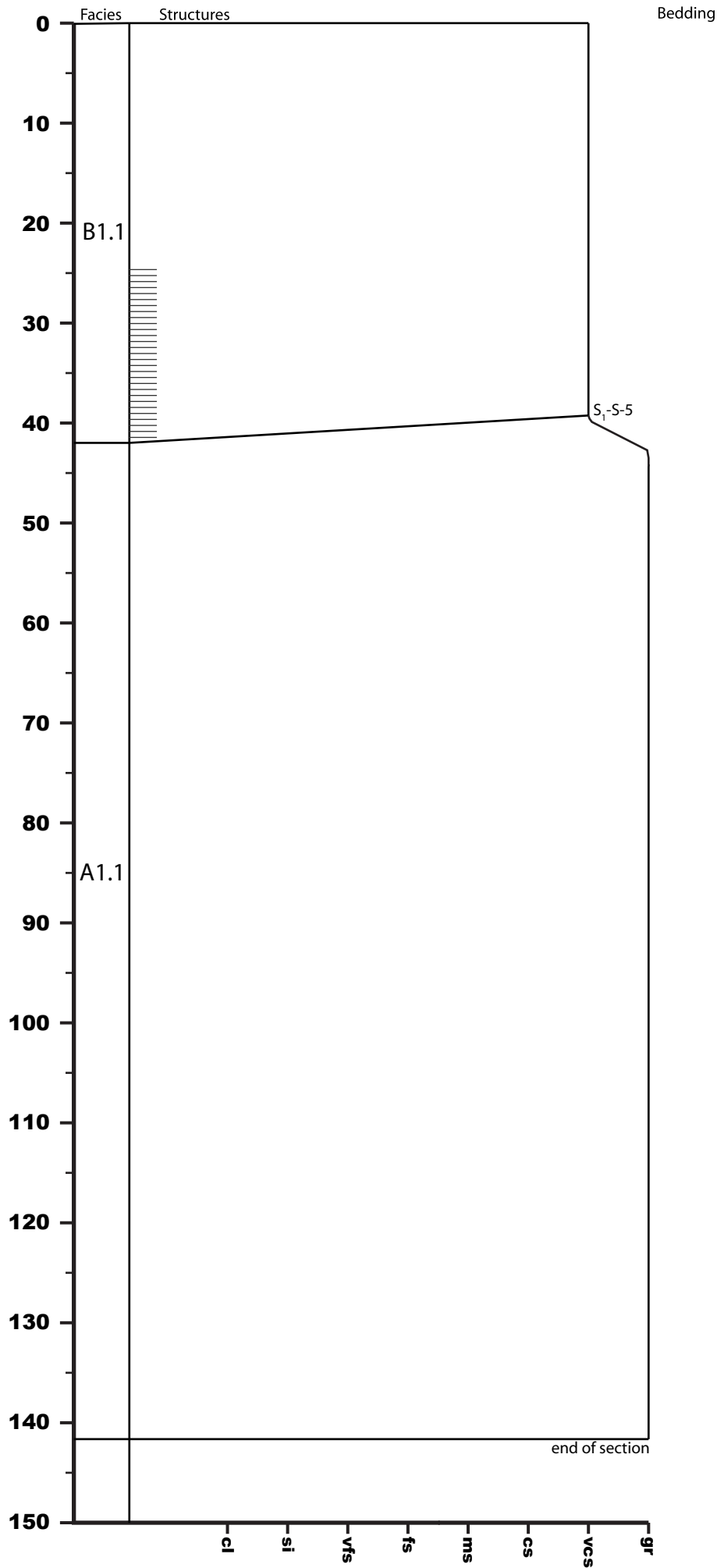



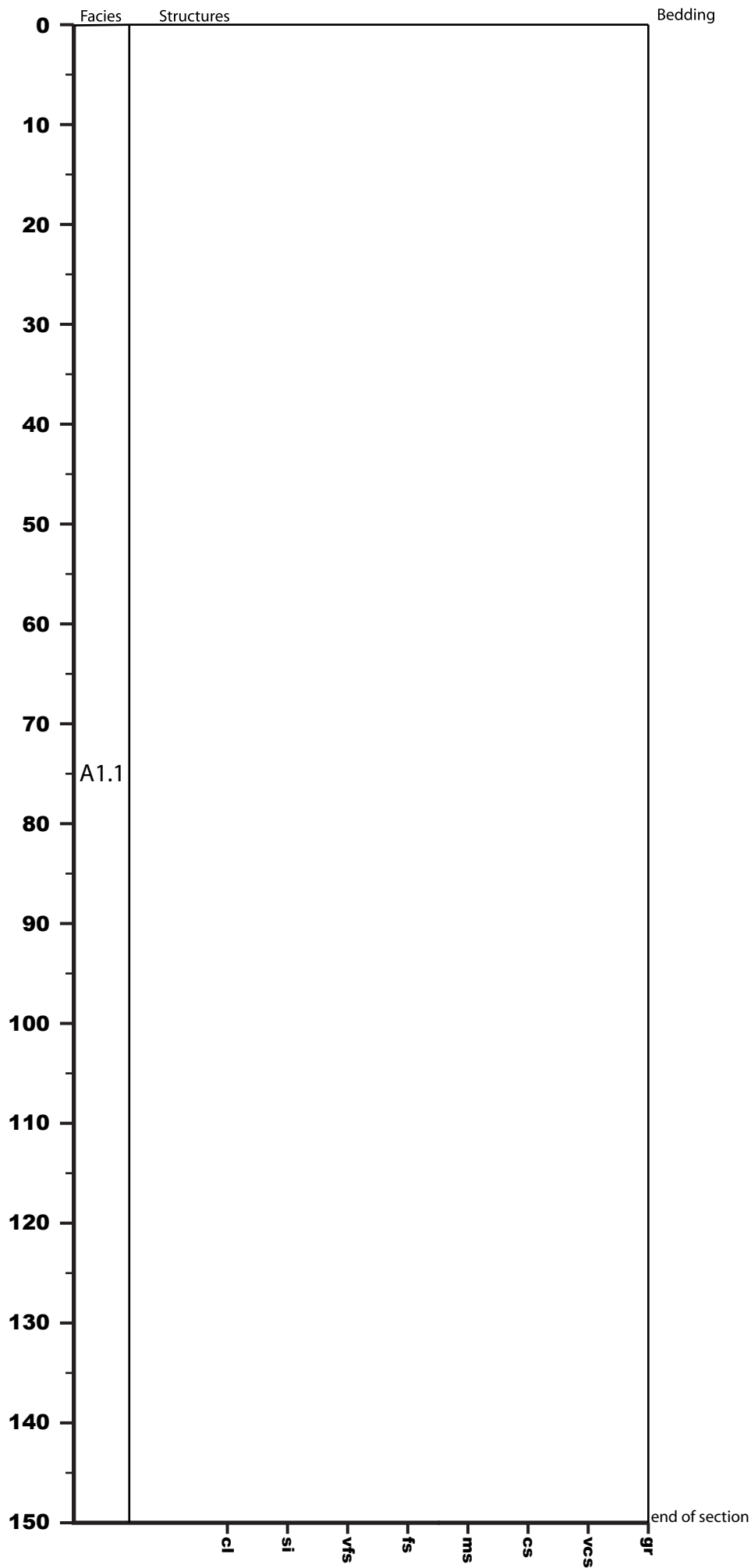

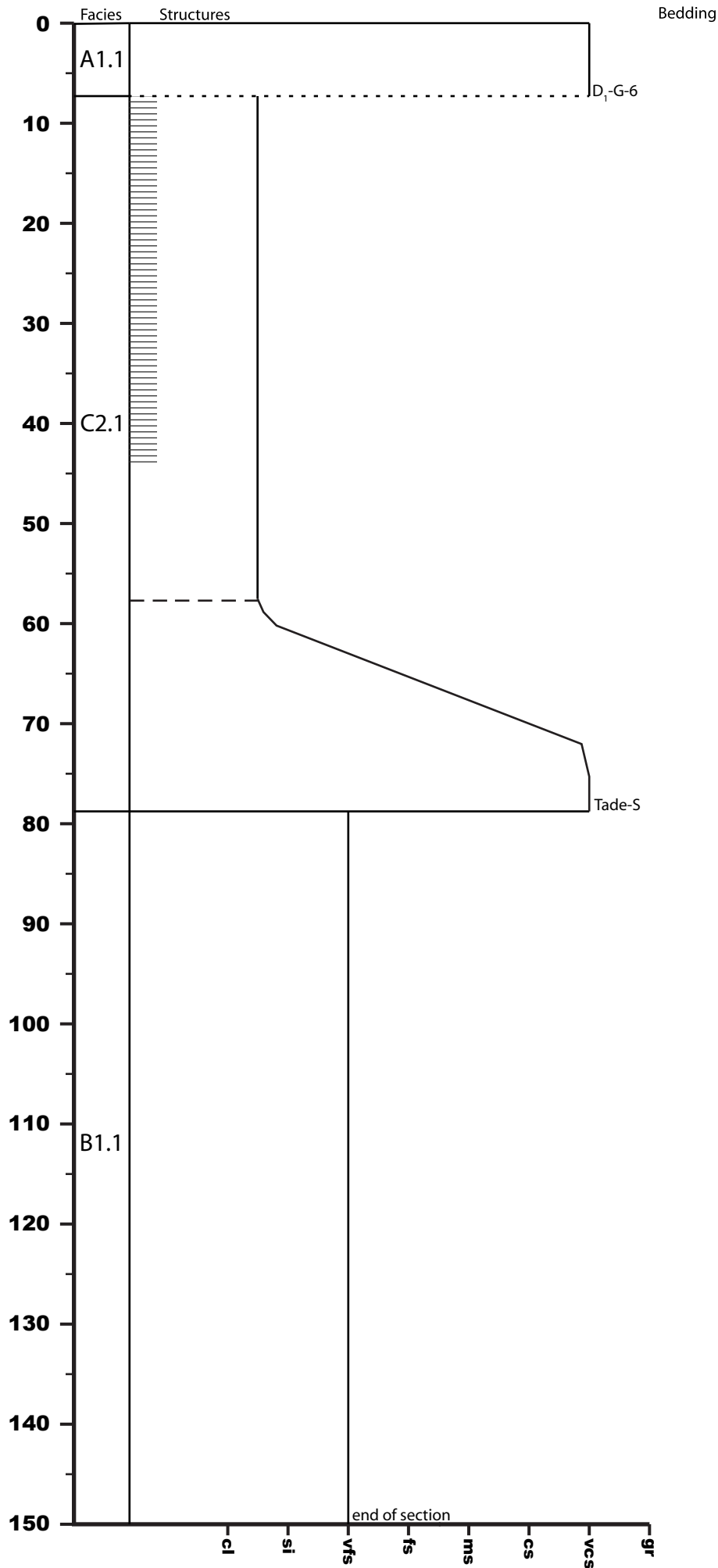

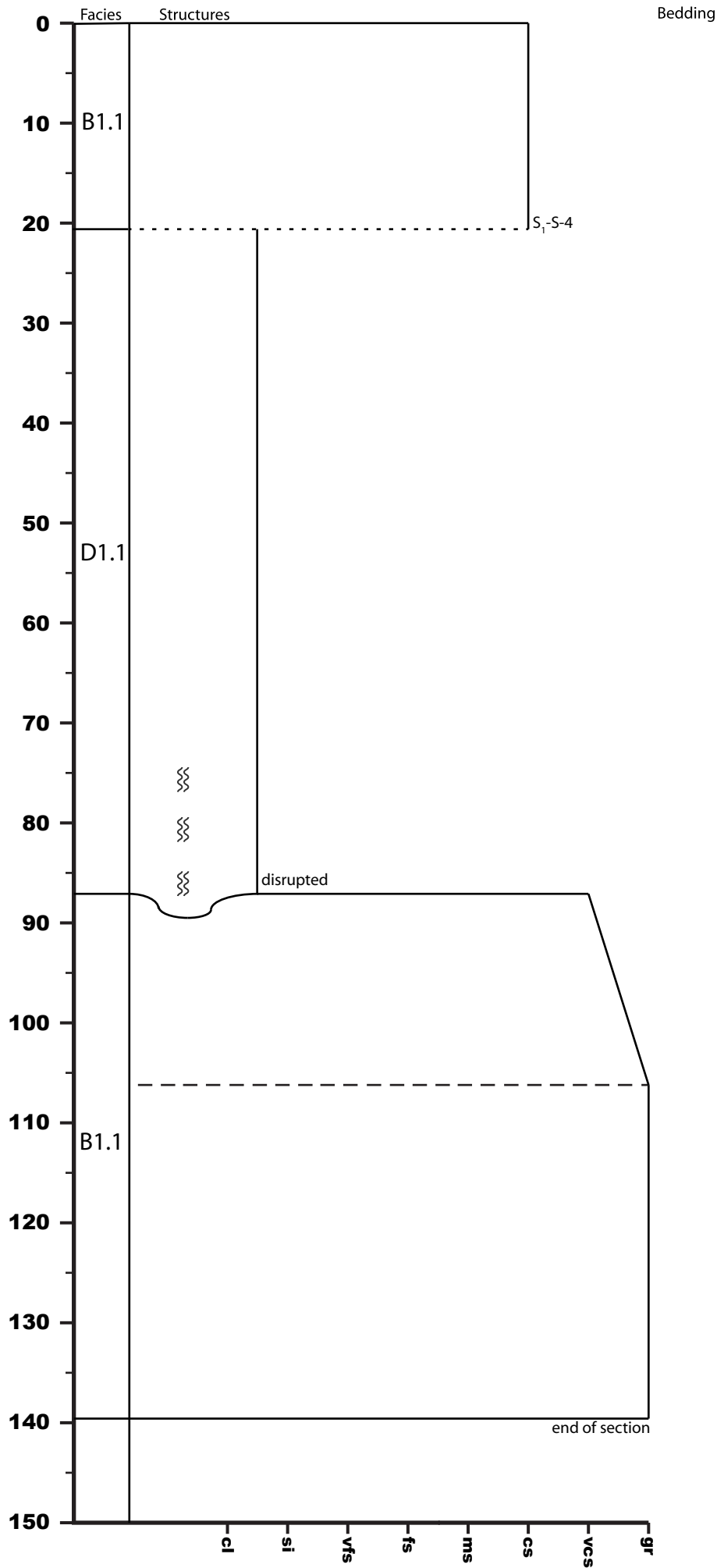

U1438E-29R-5

1115.41 - 1116.91 mbsf

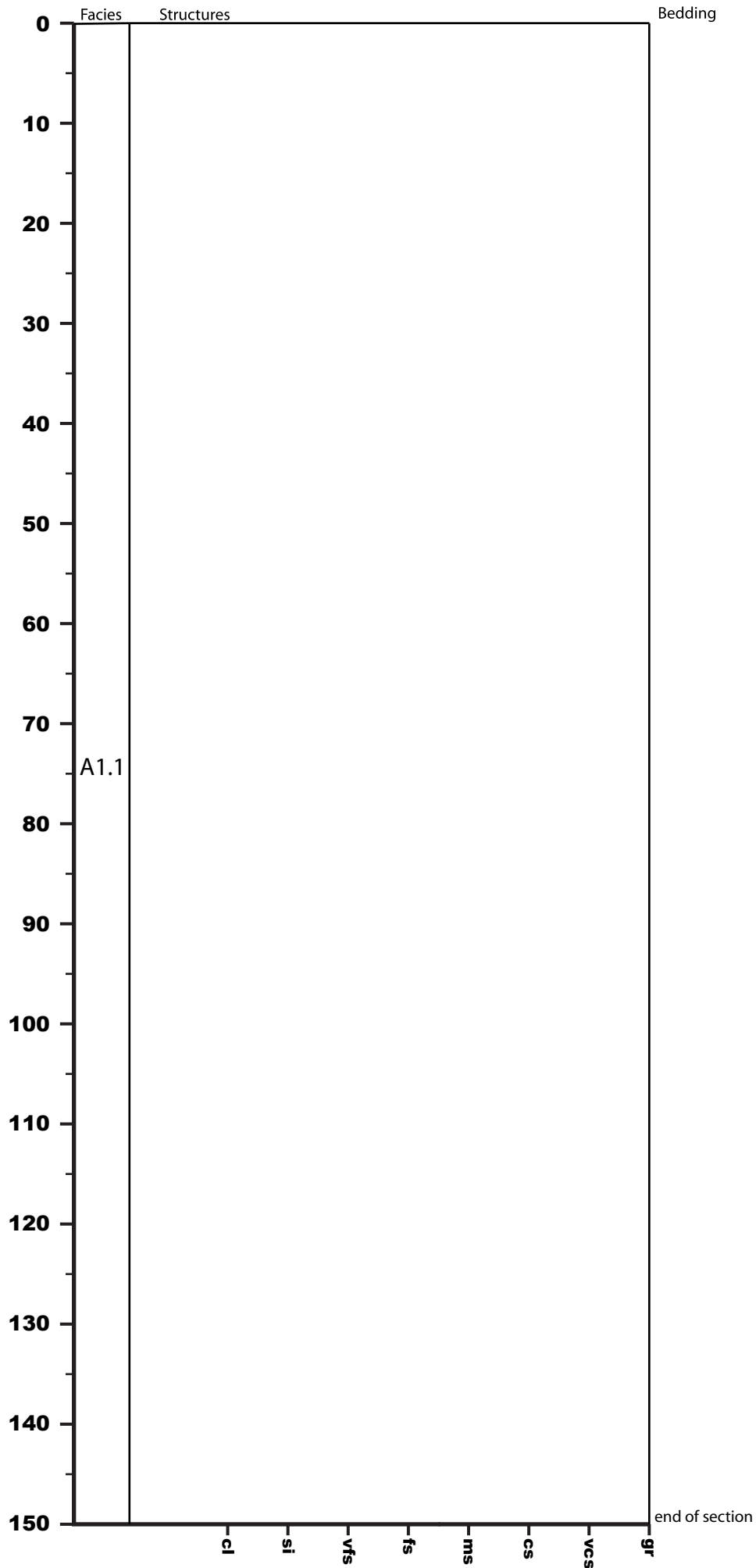

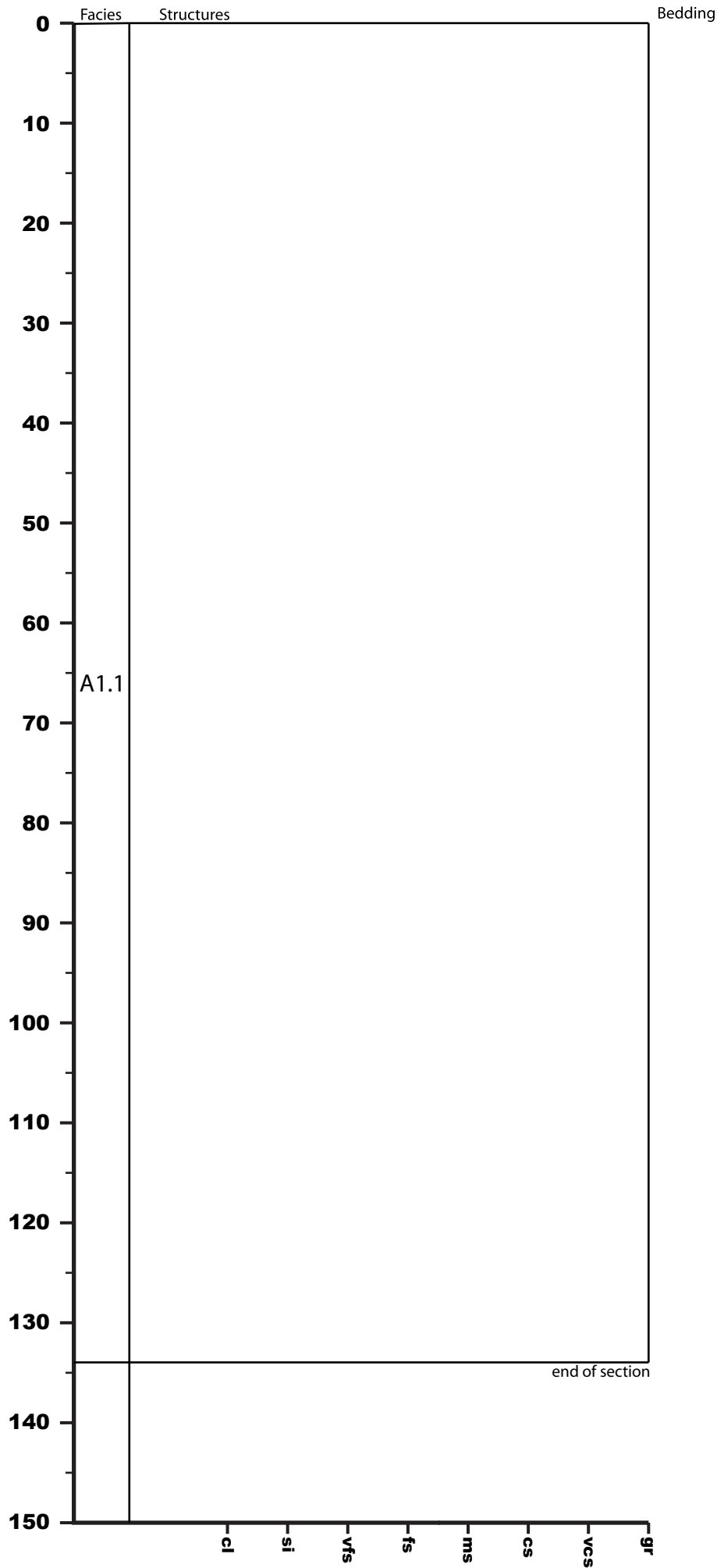

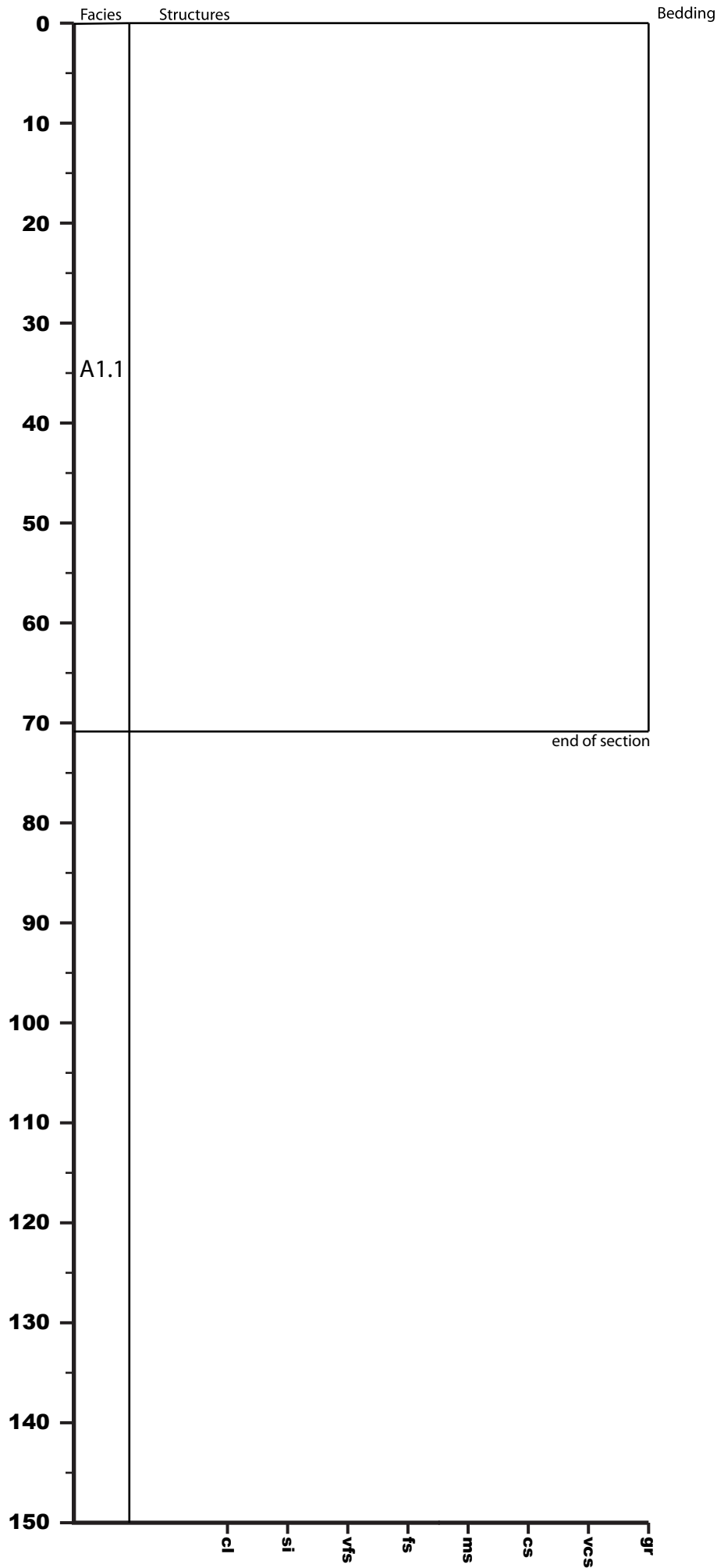

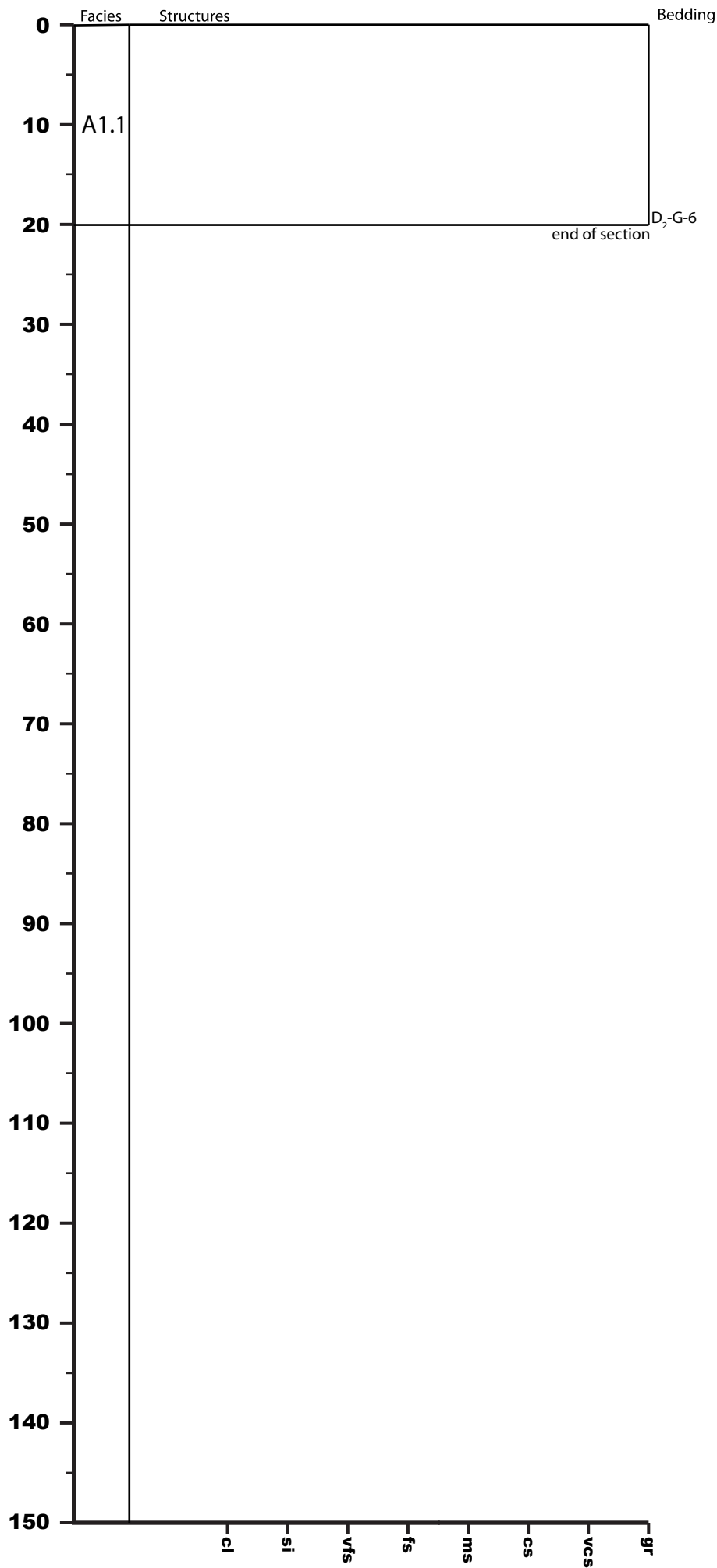

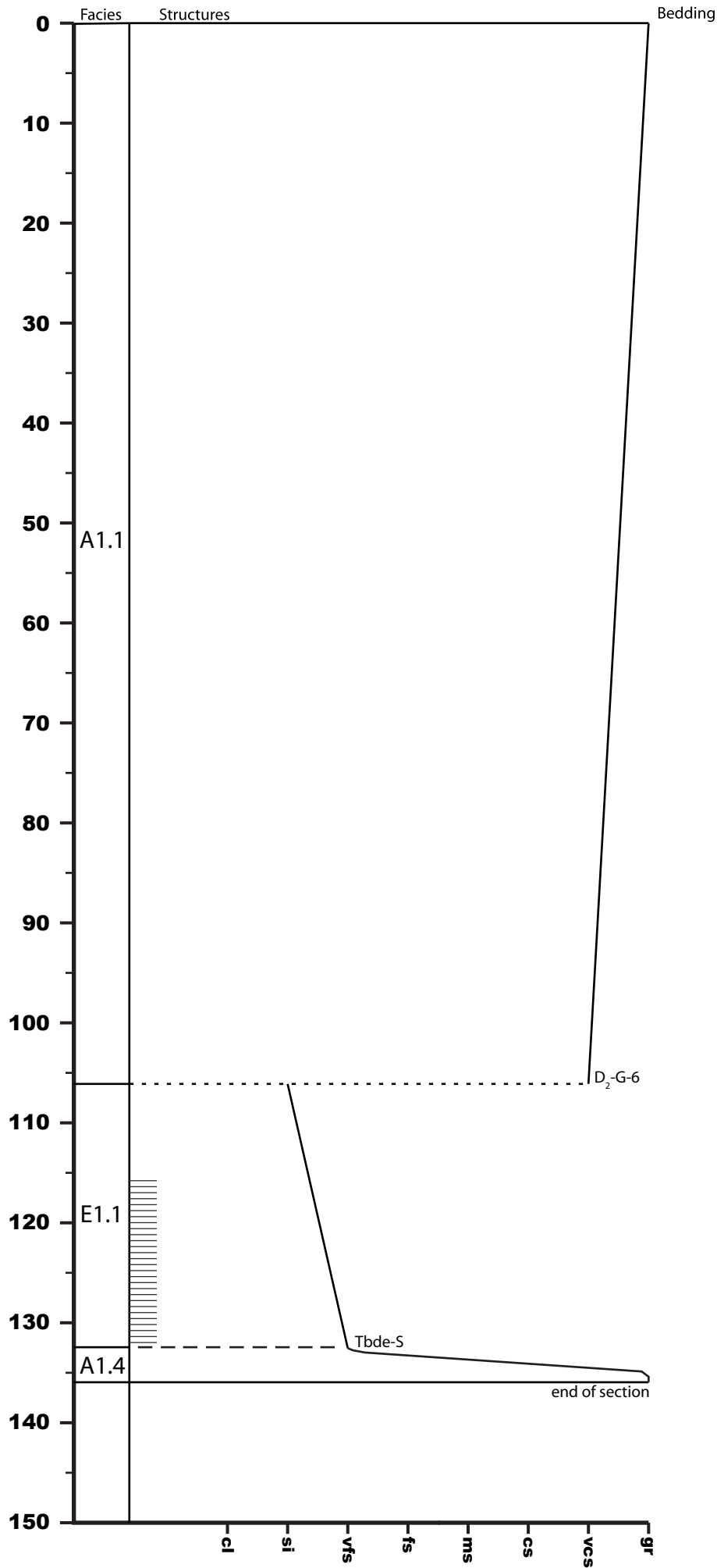



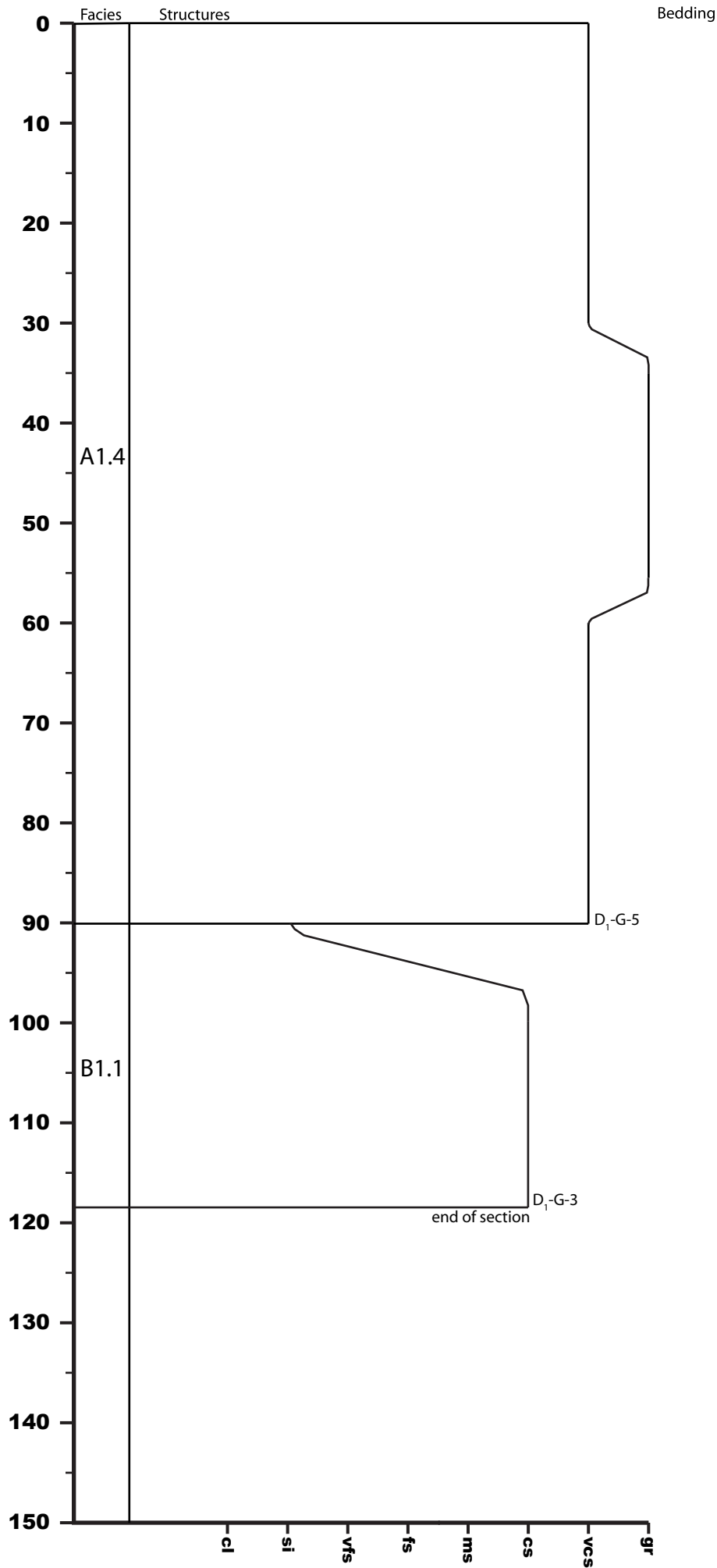

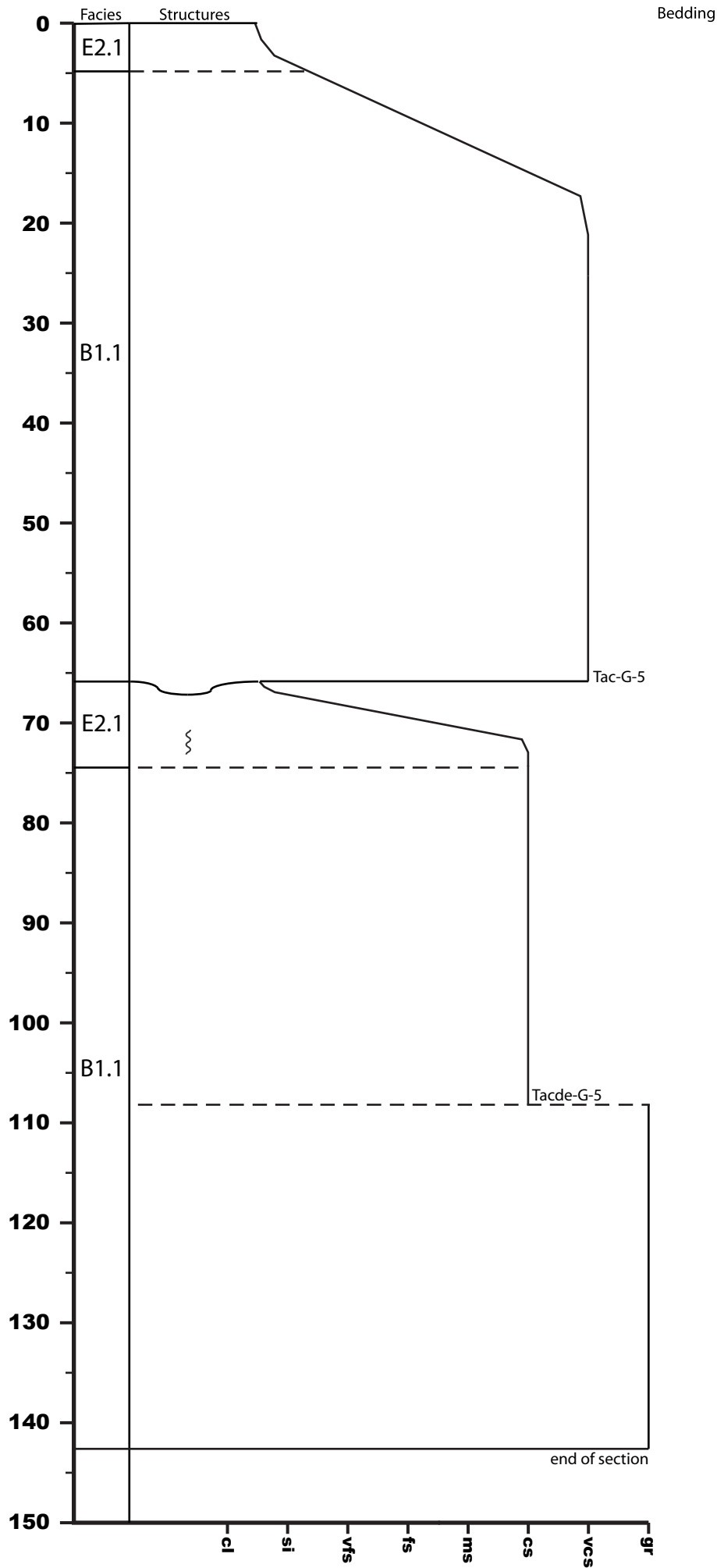

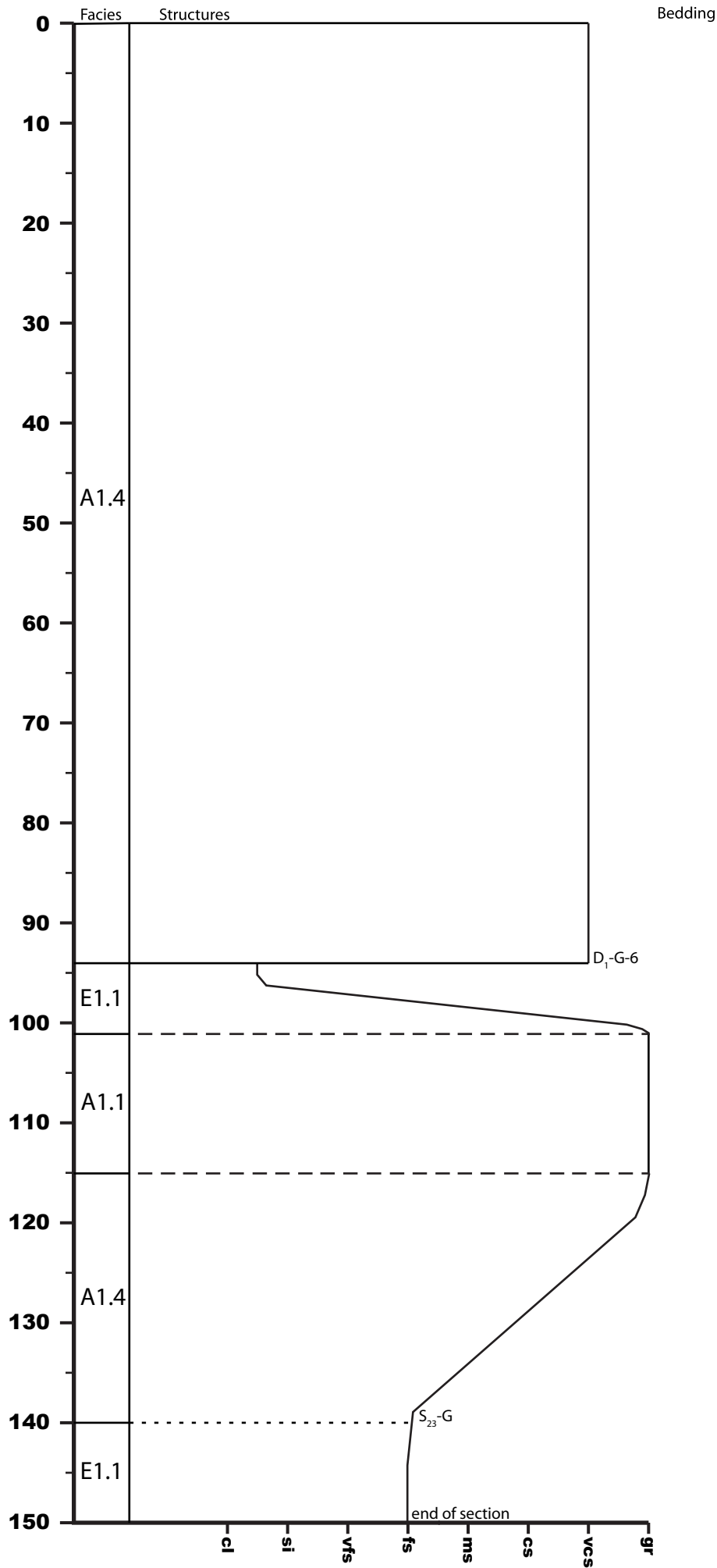

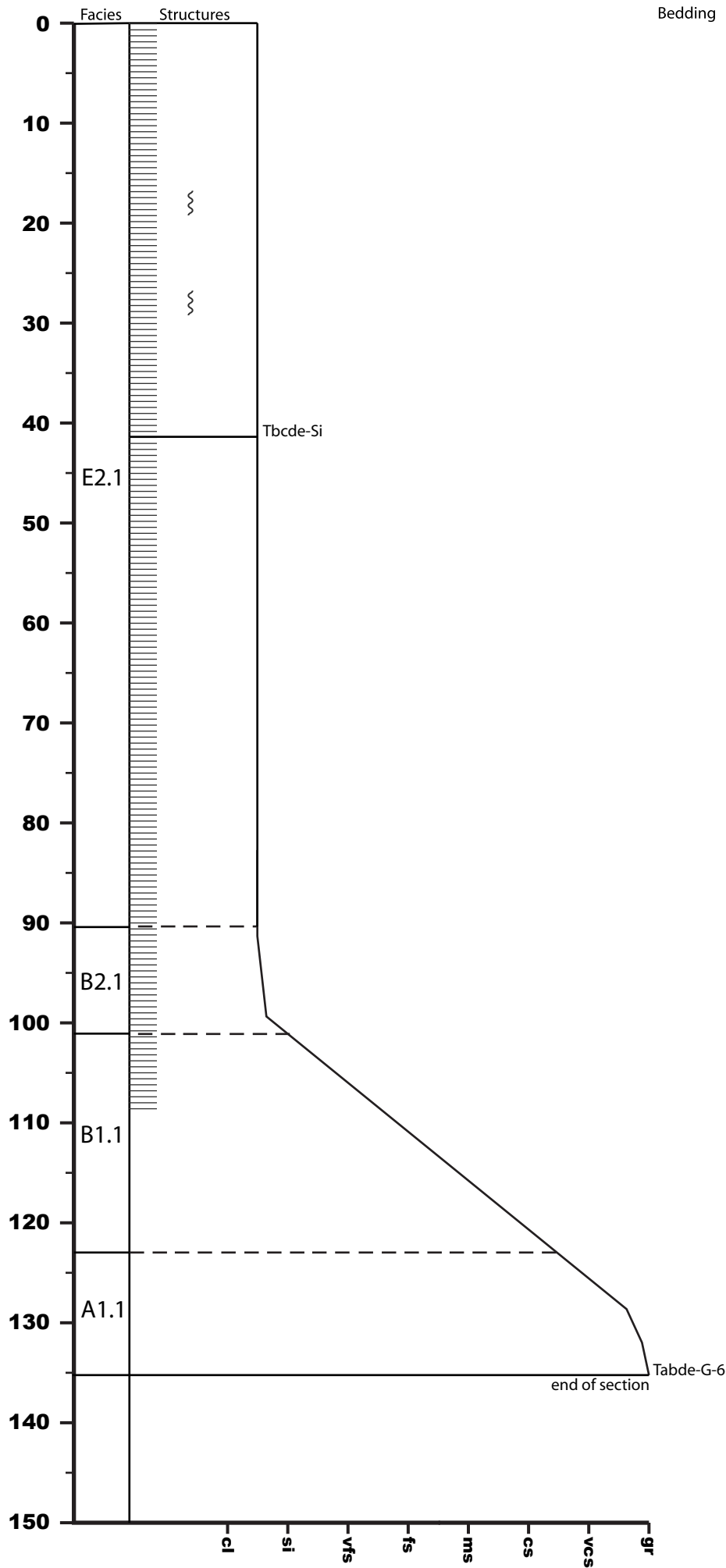

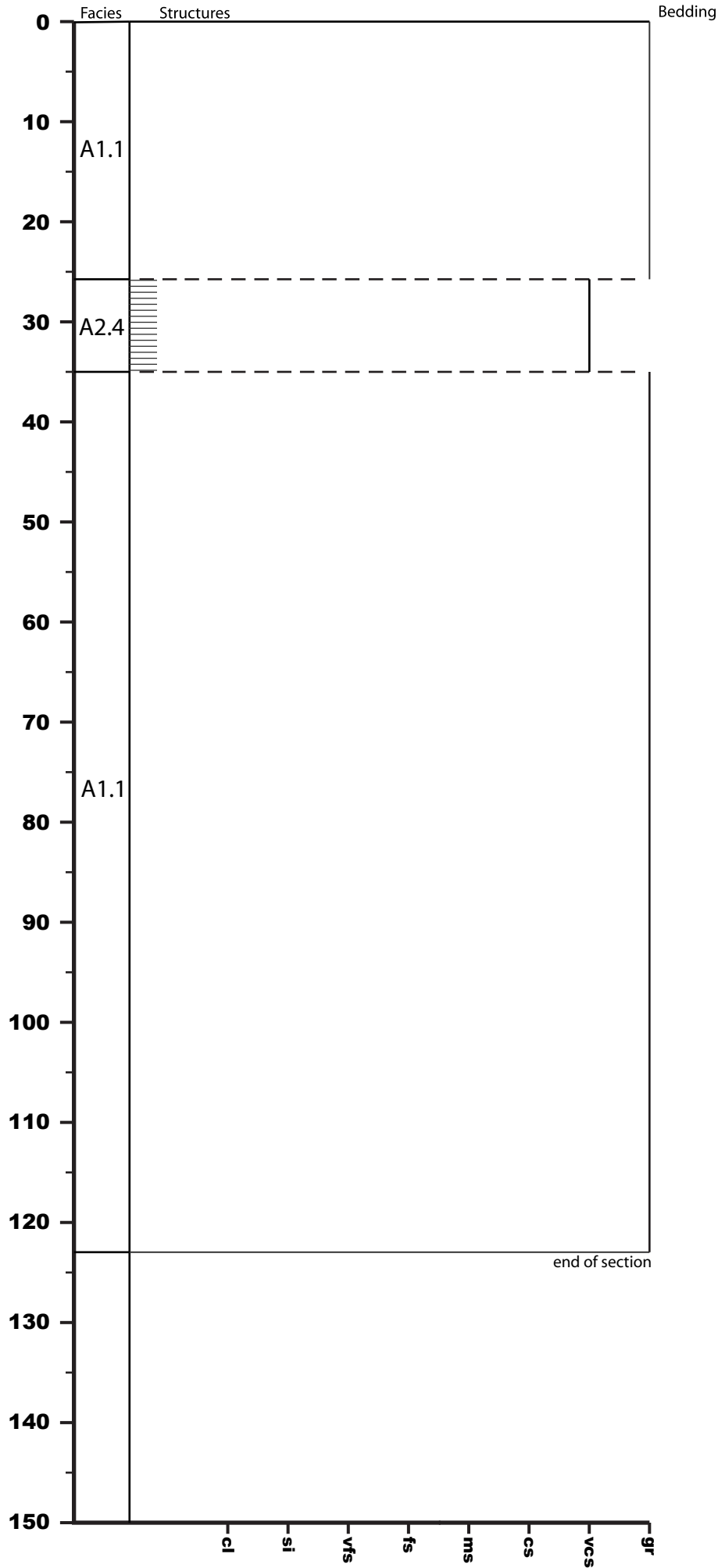

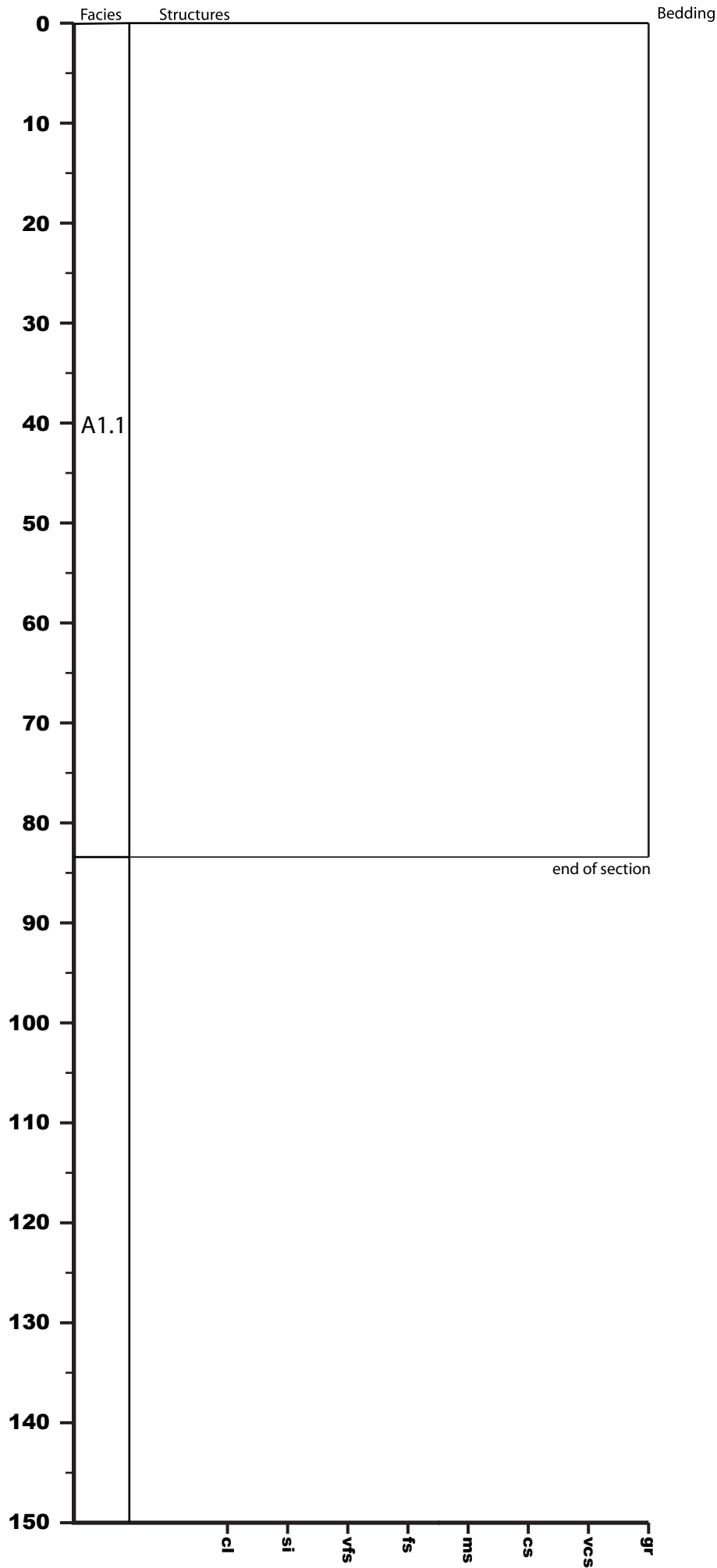

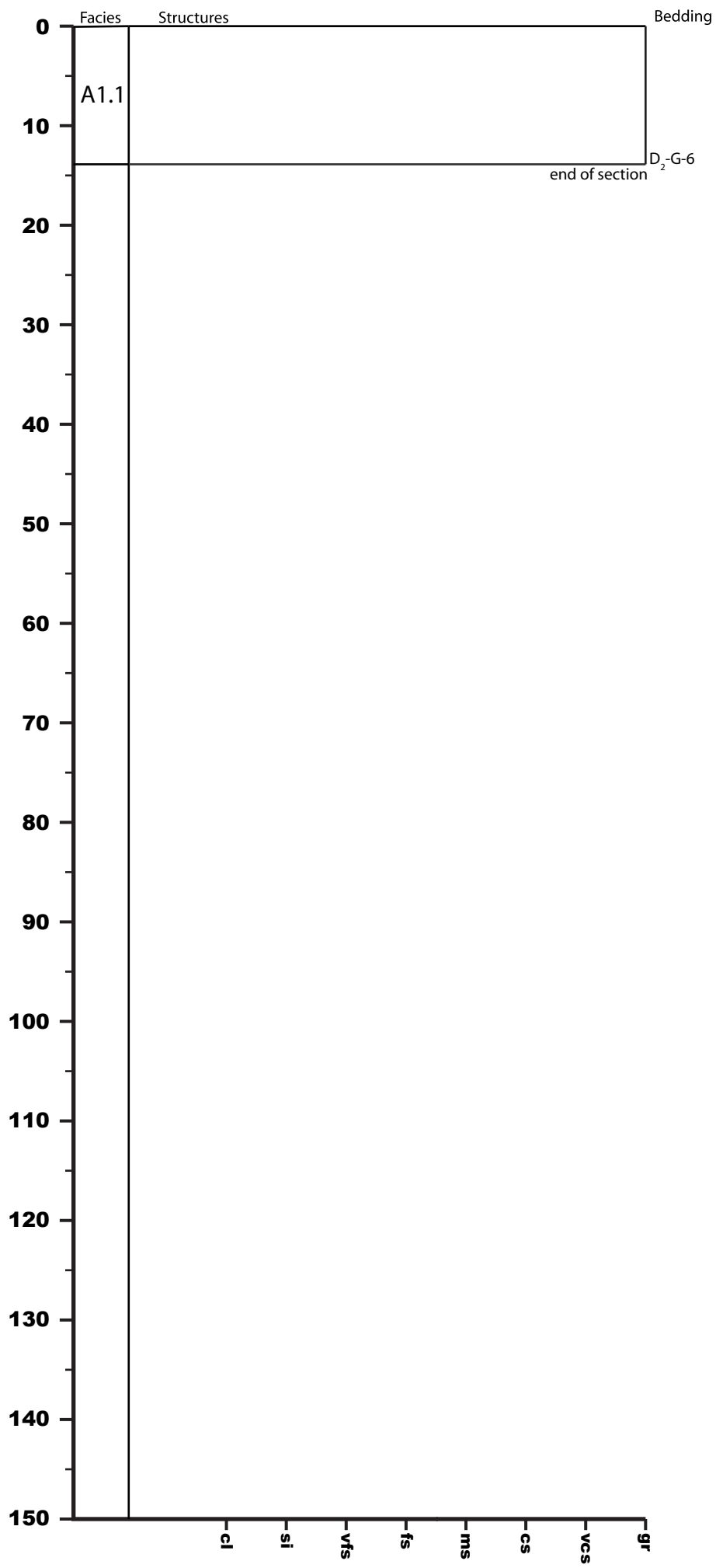

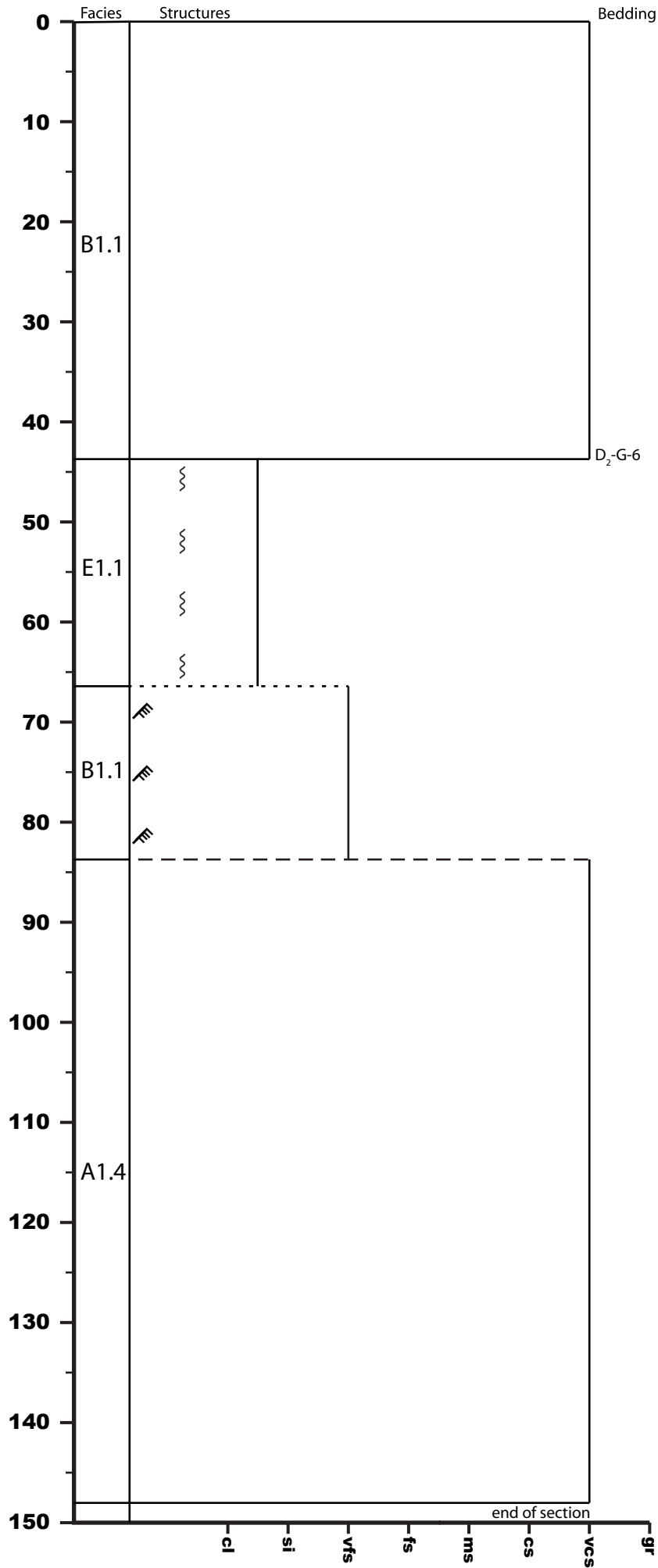



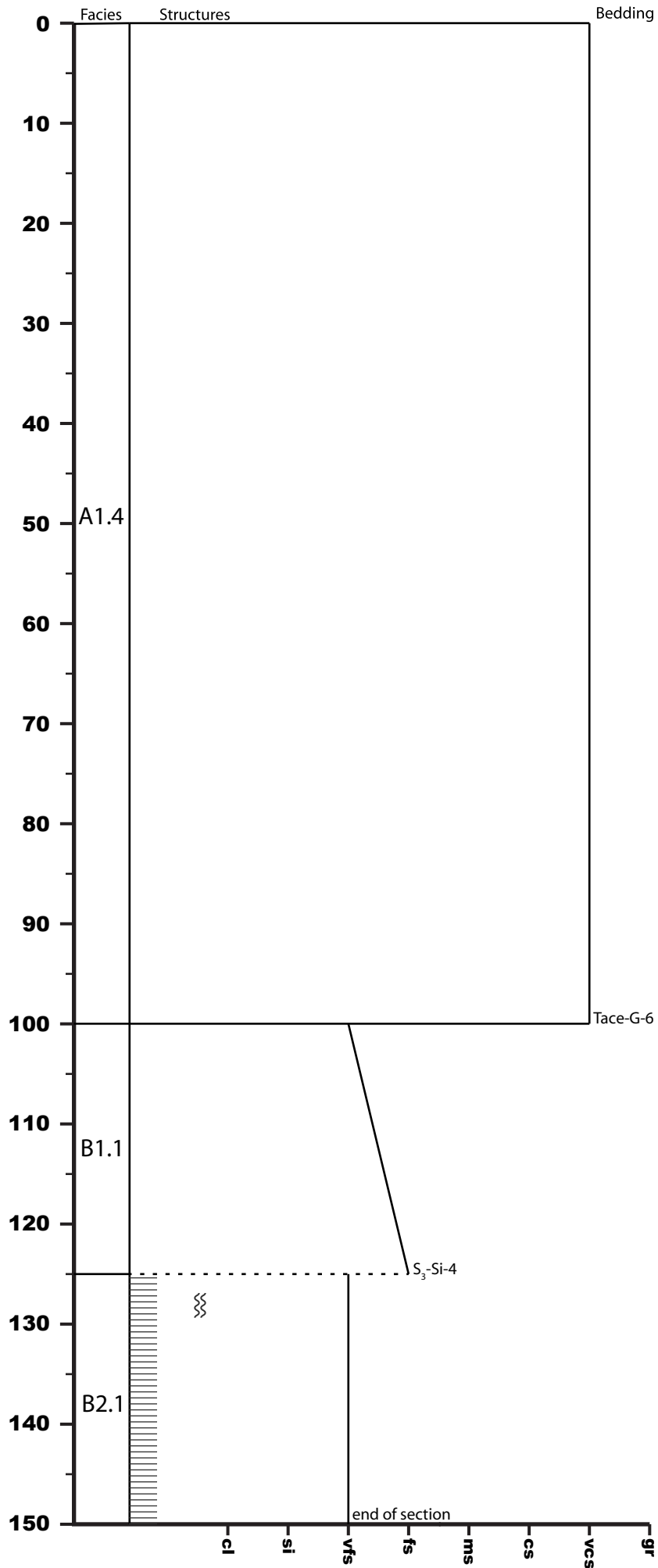

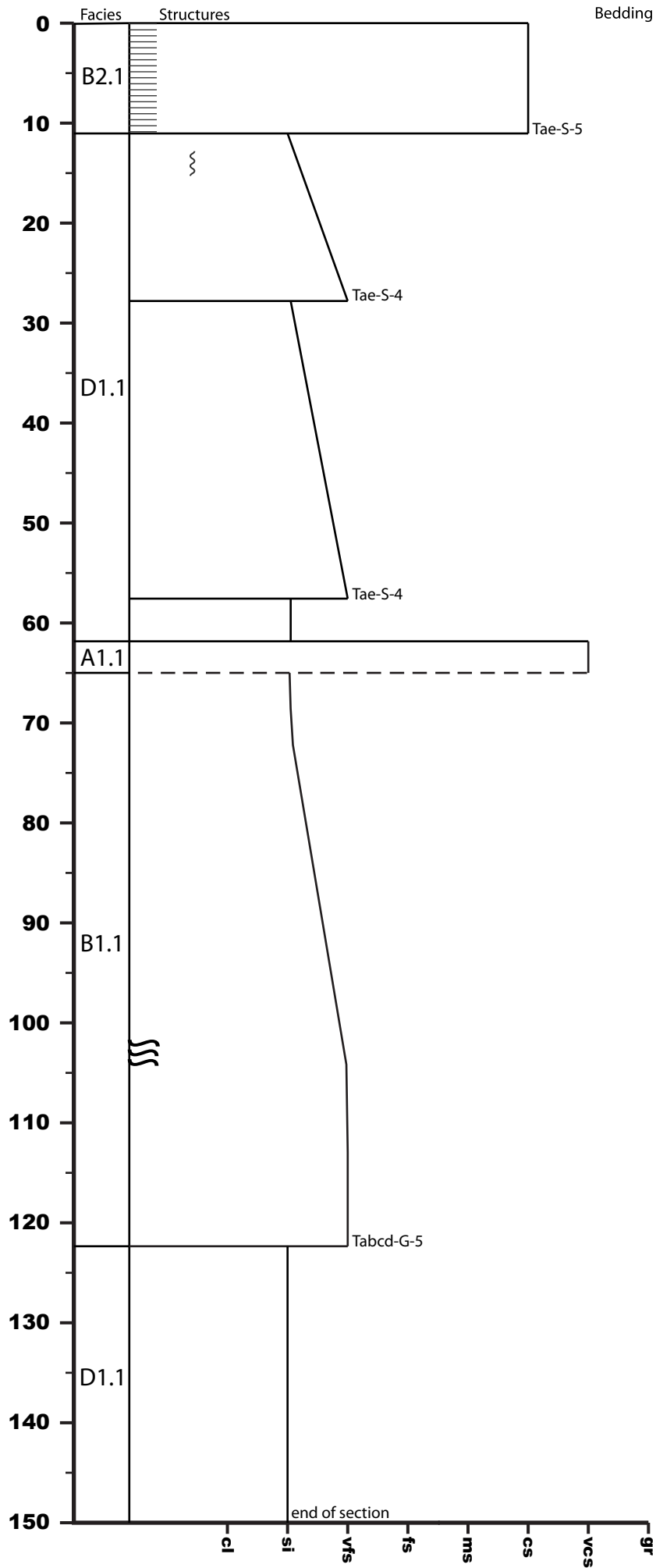

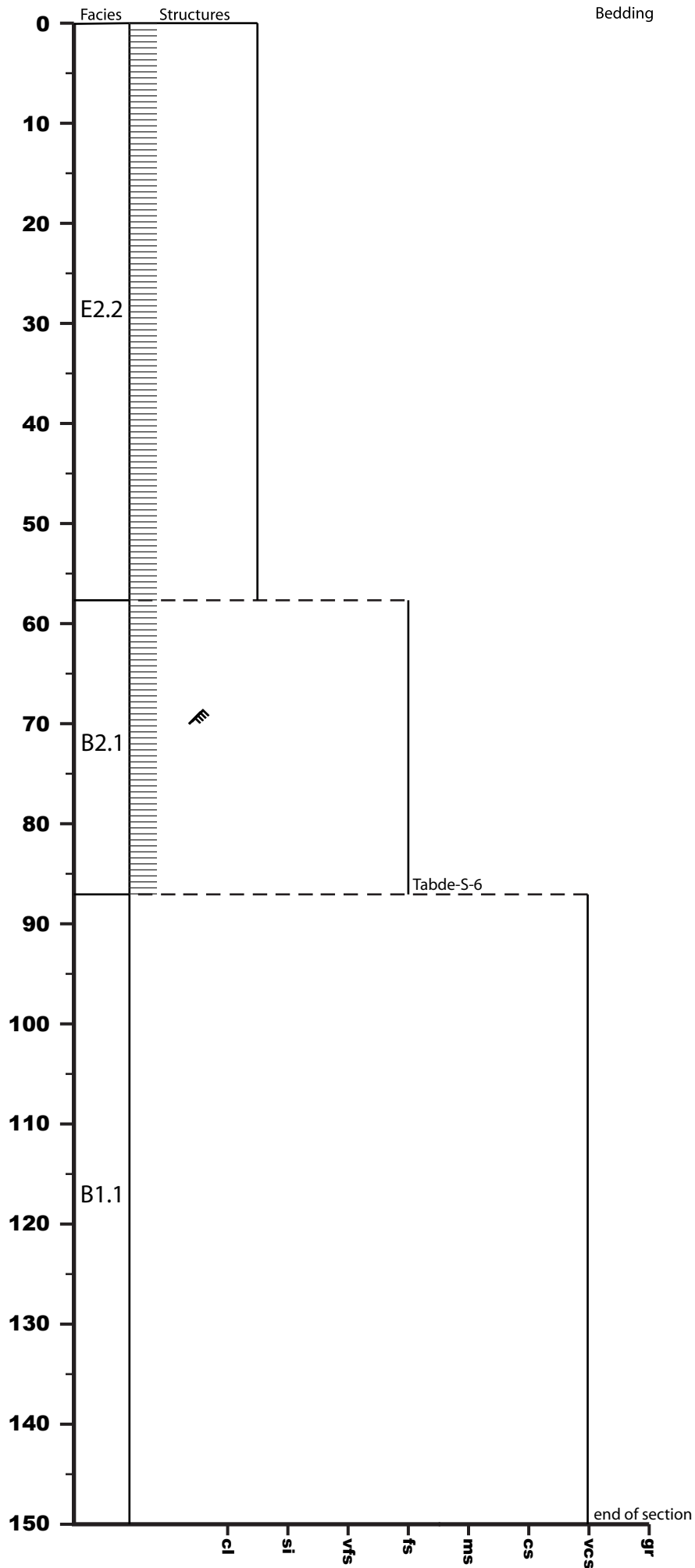

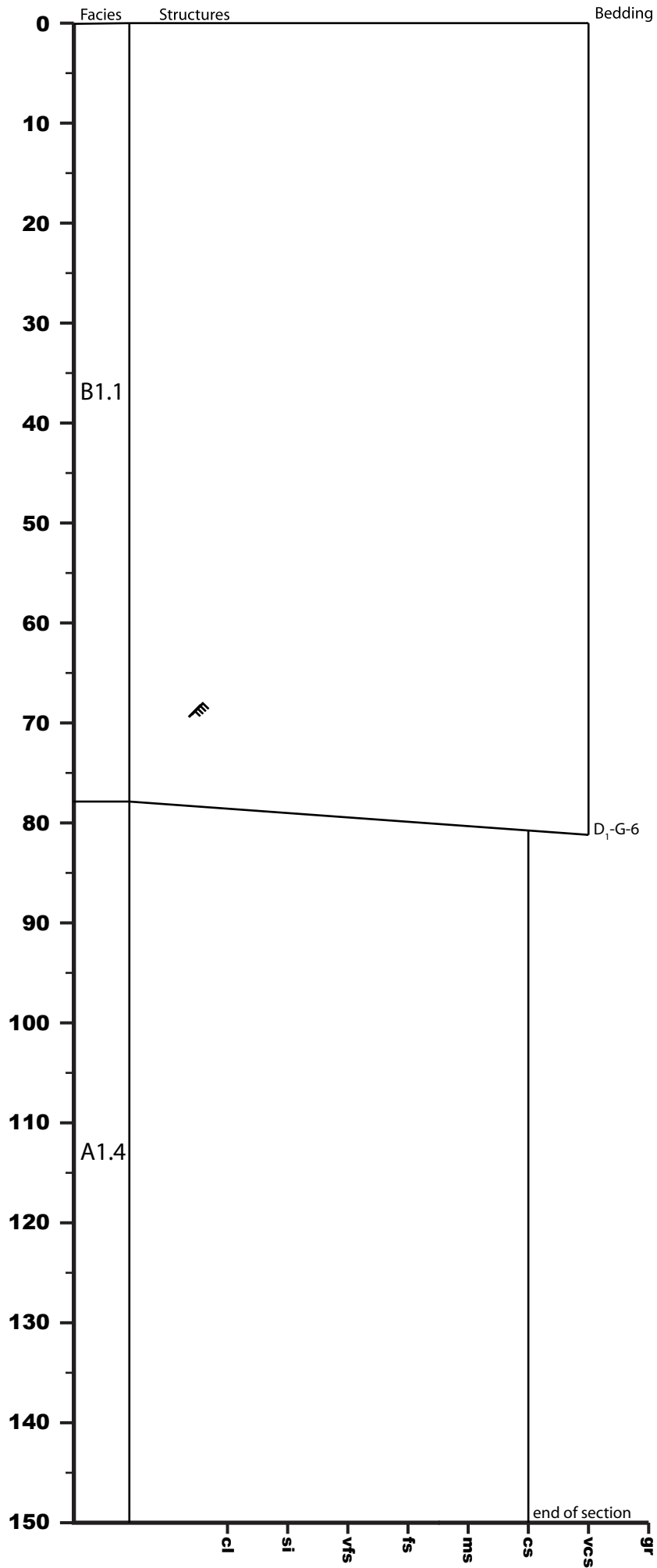

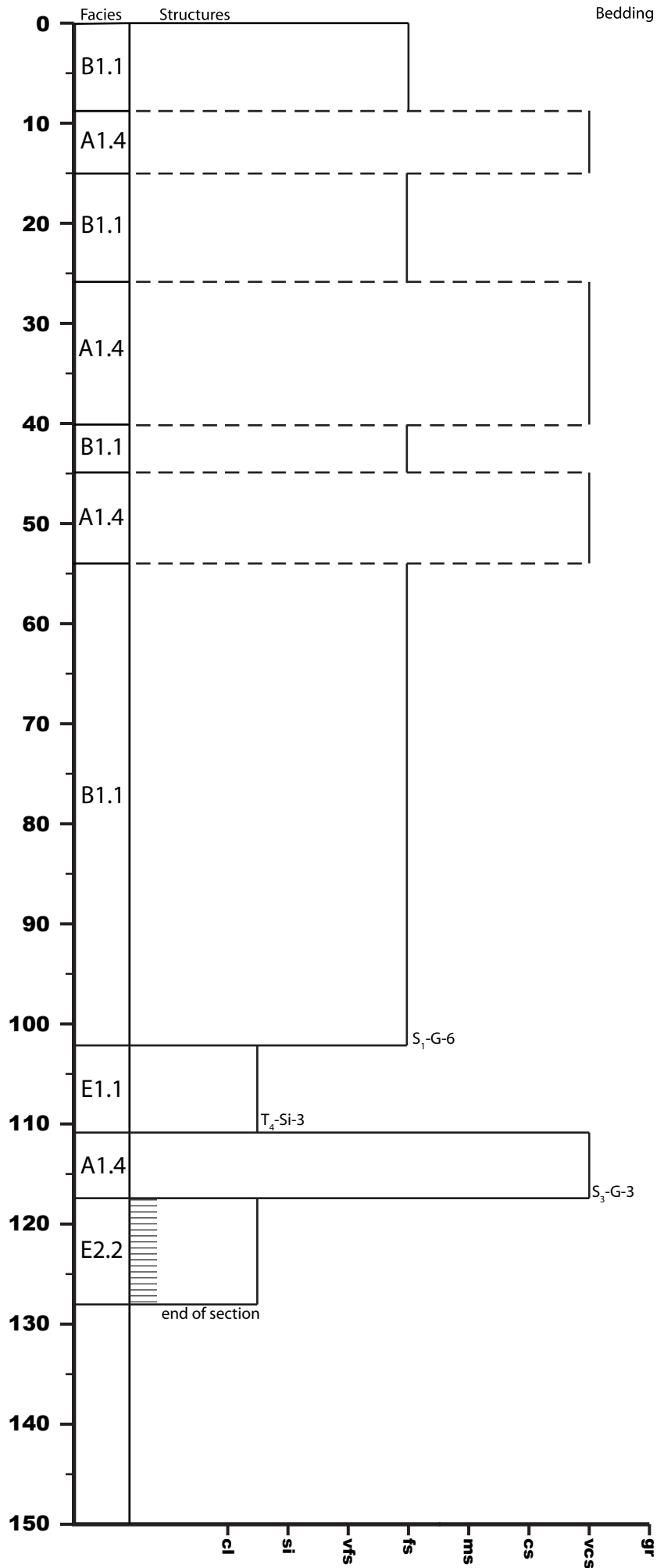

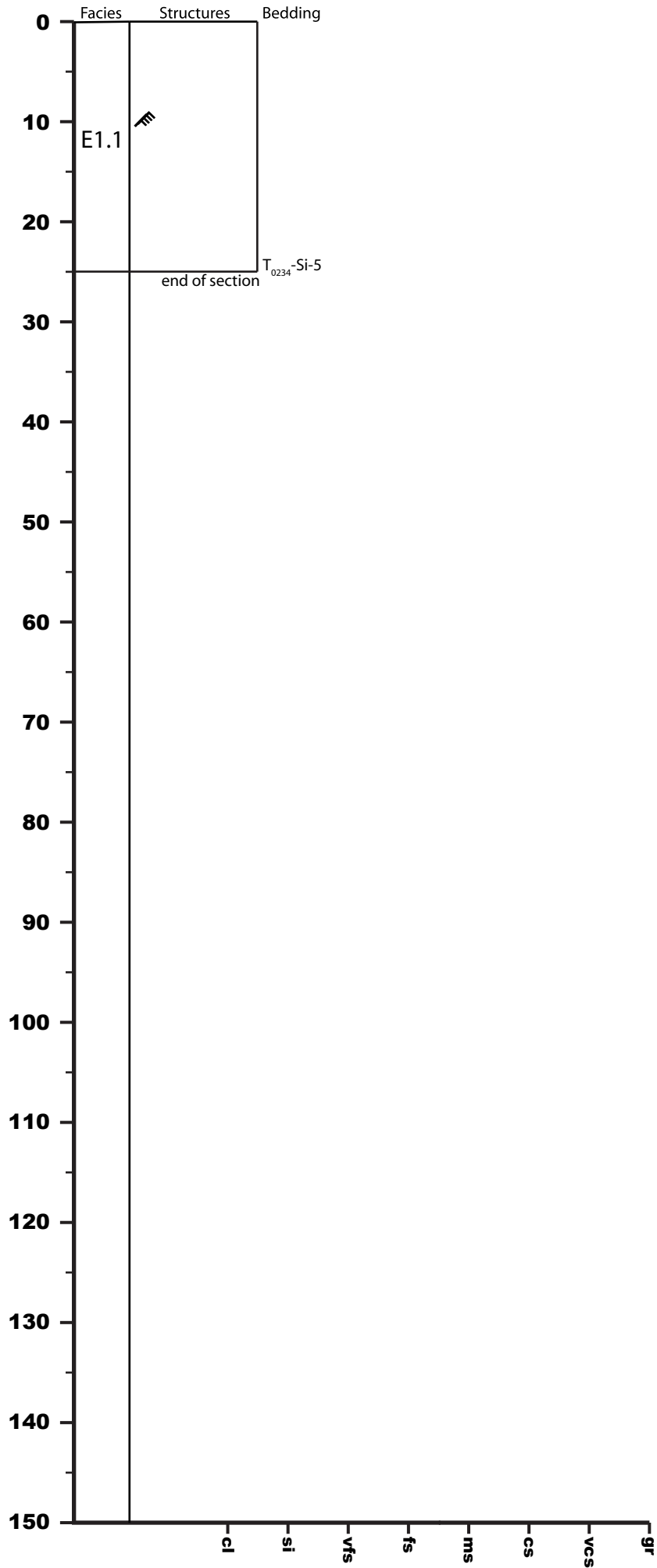

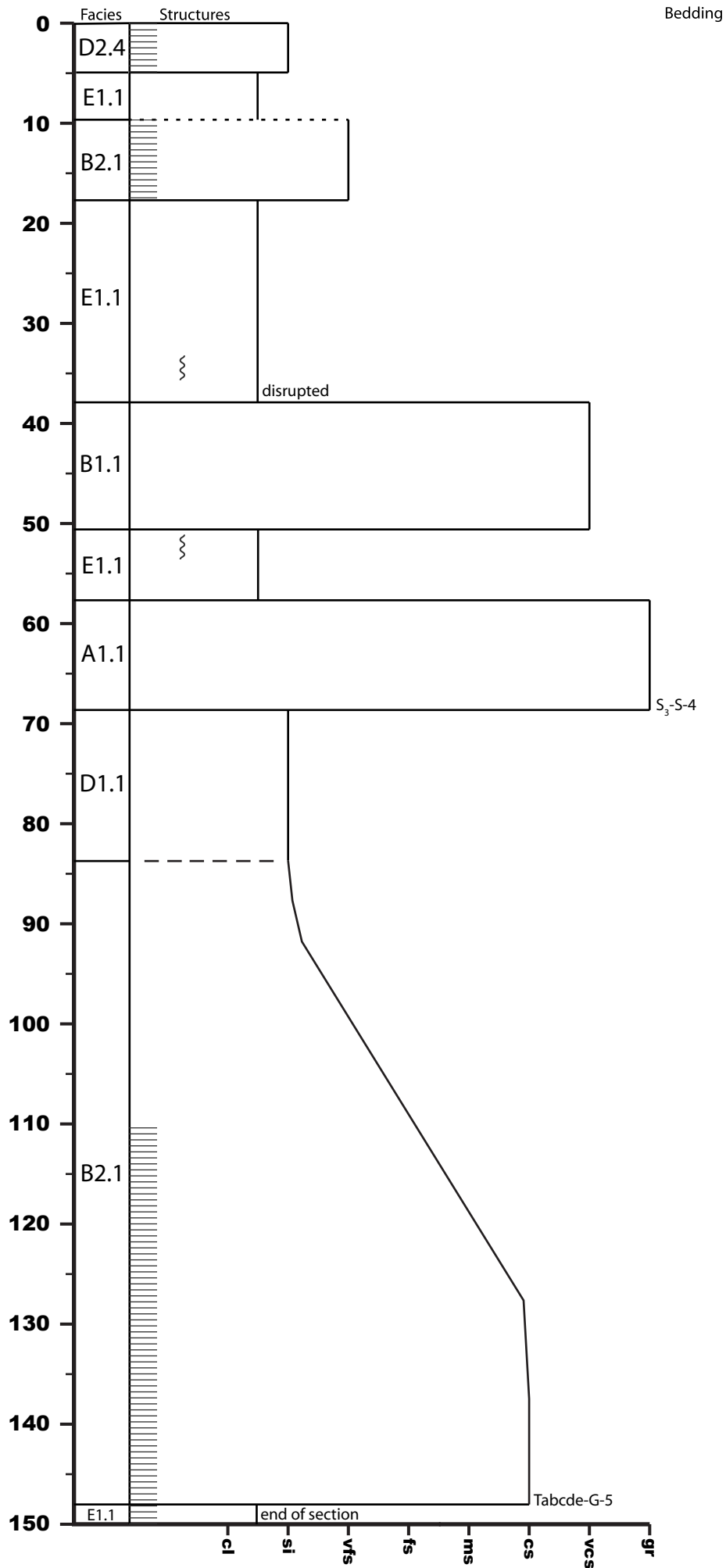

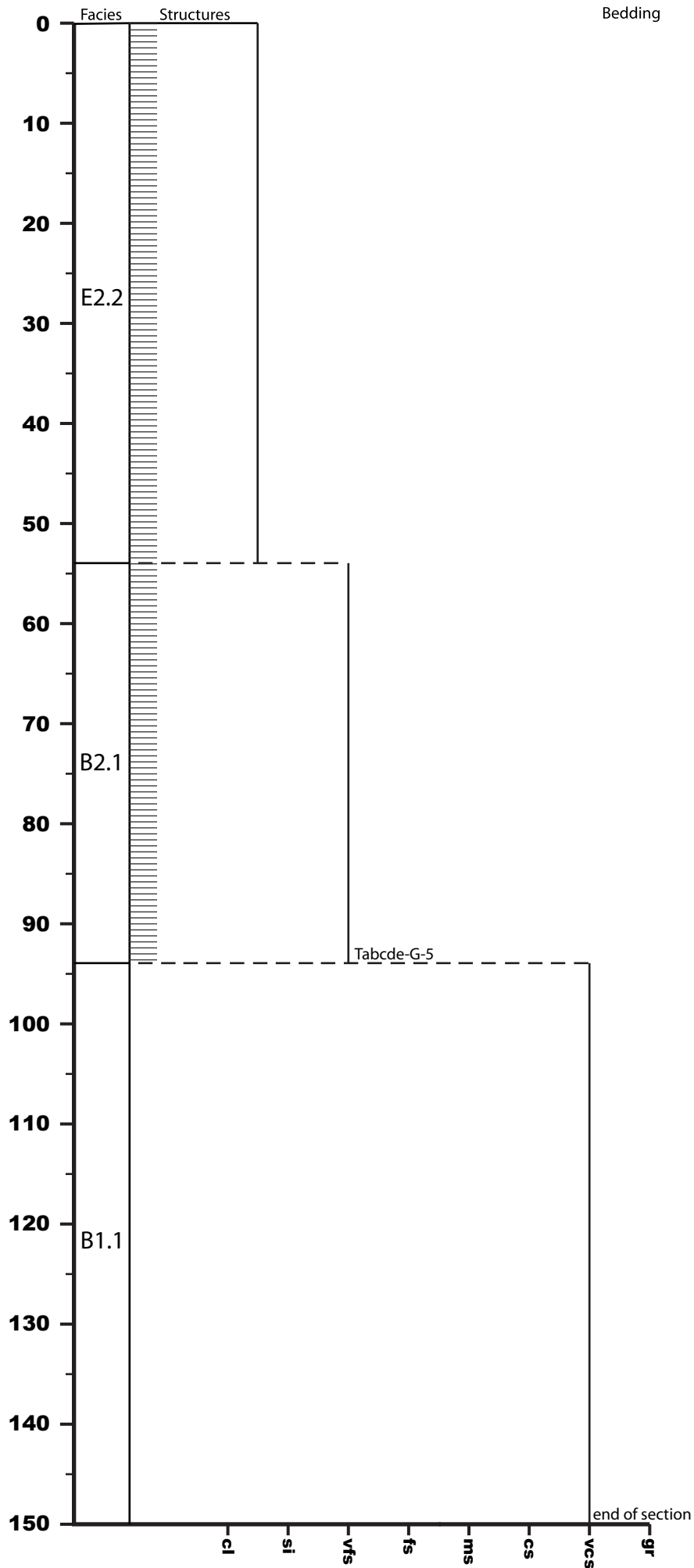



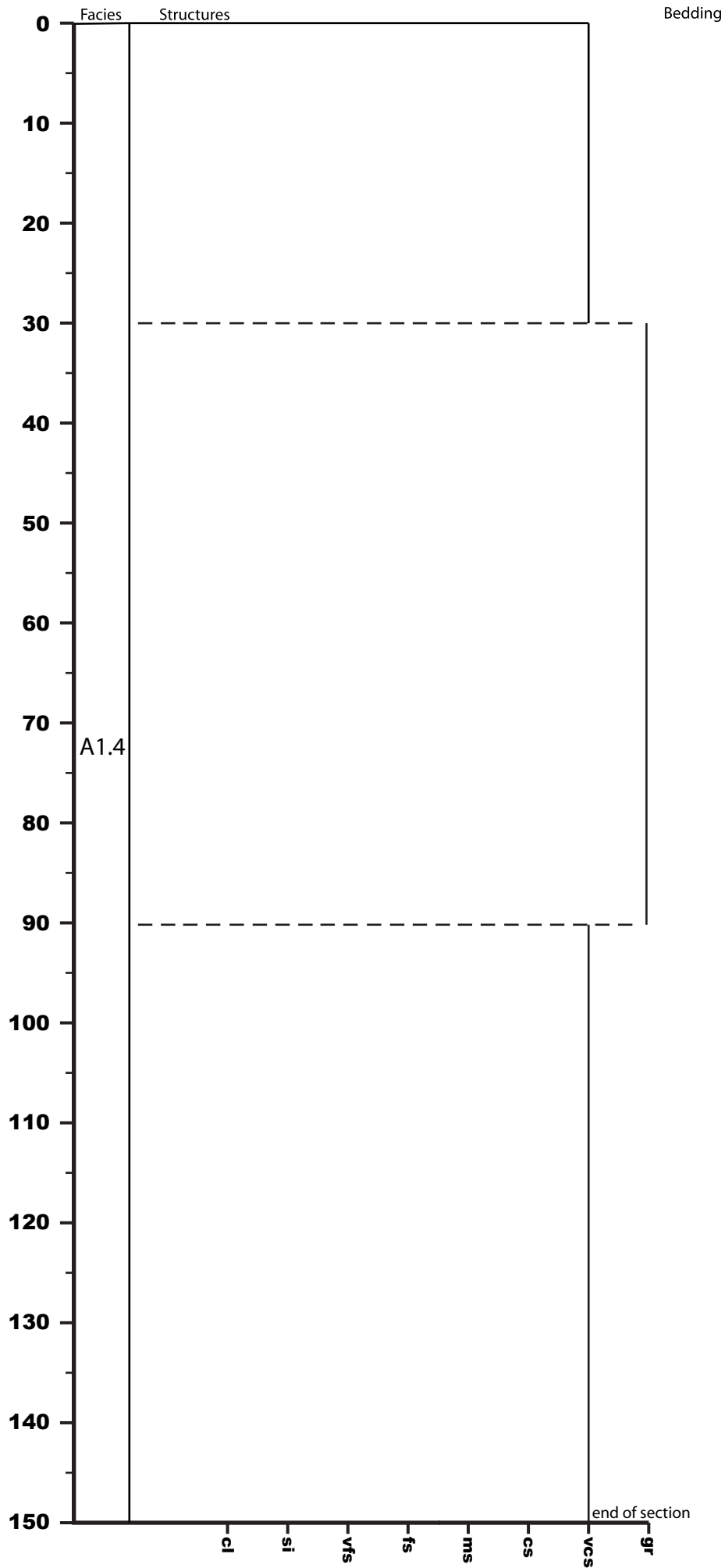

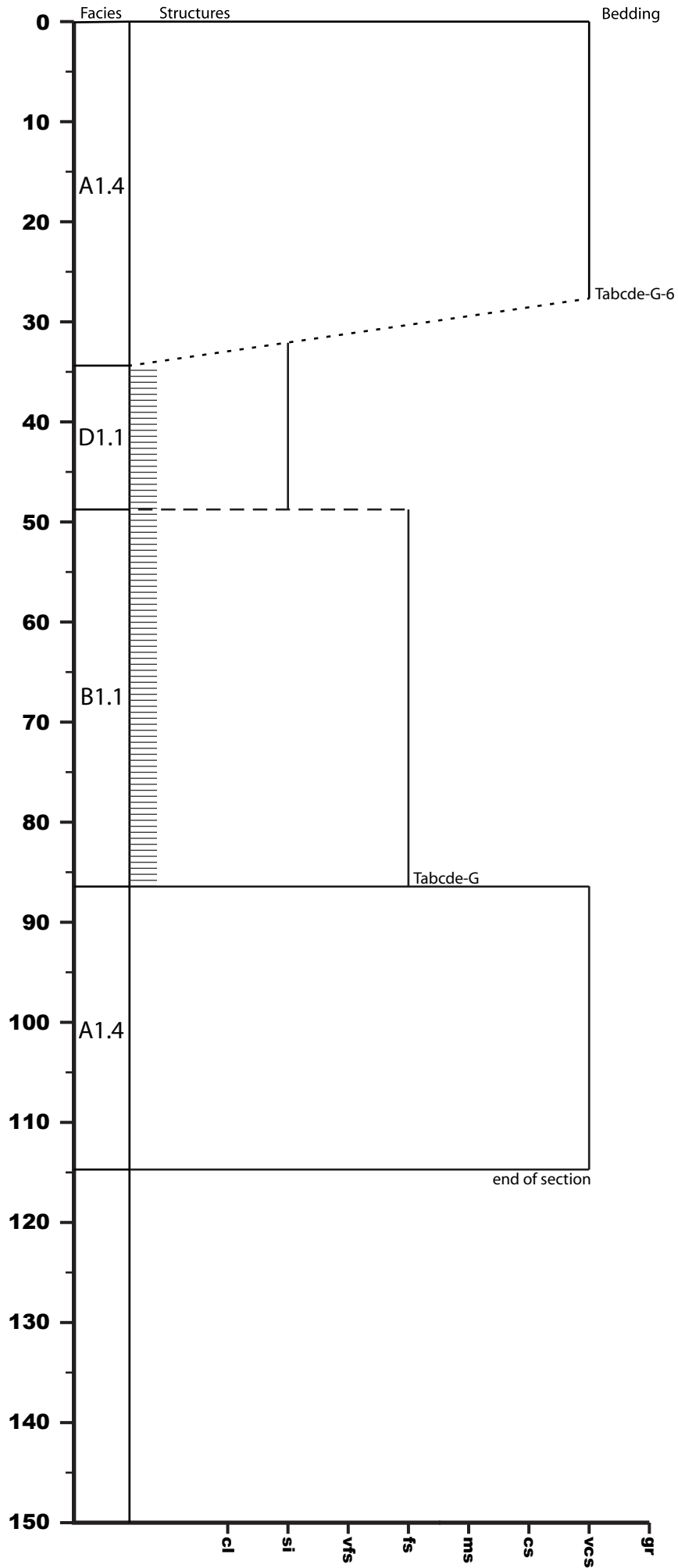

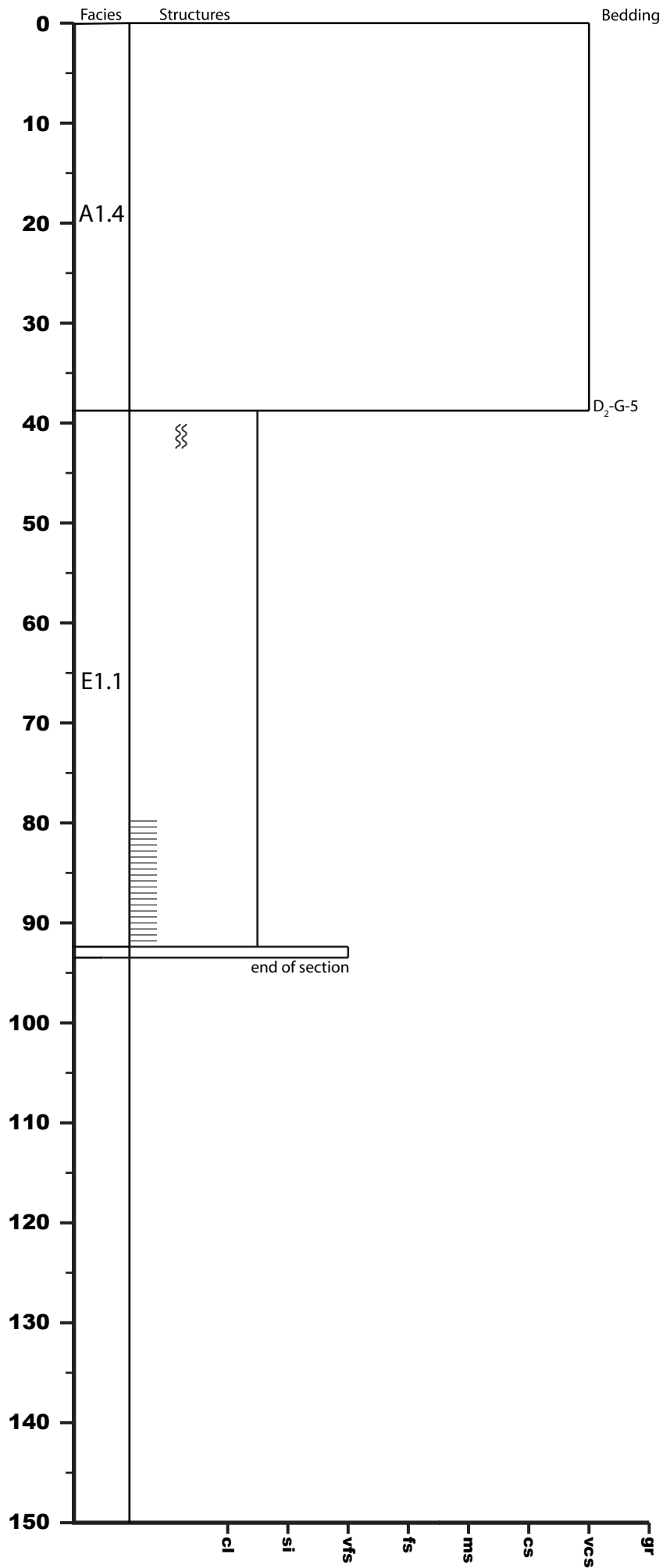

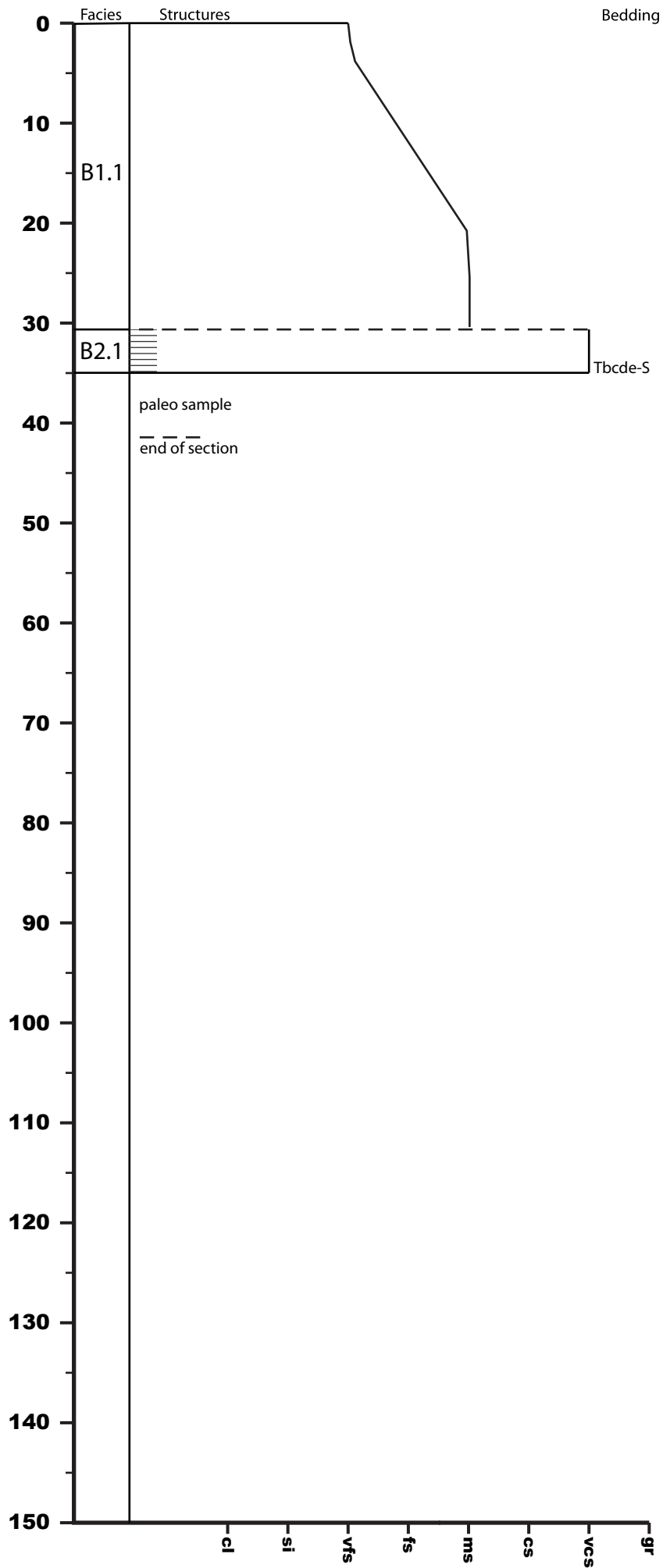

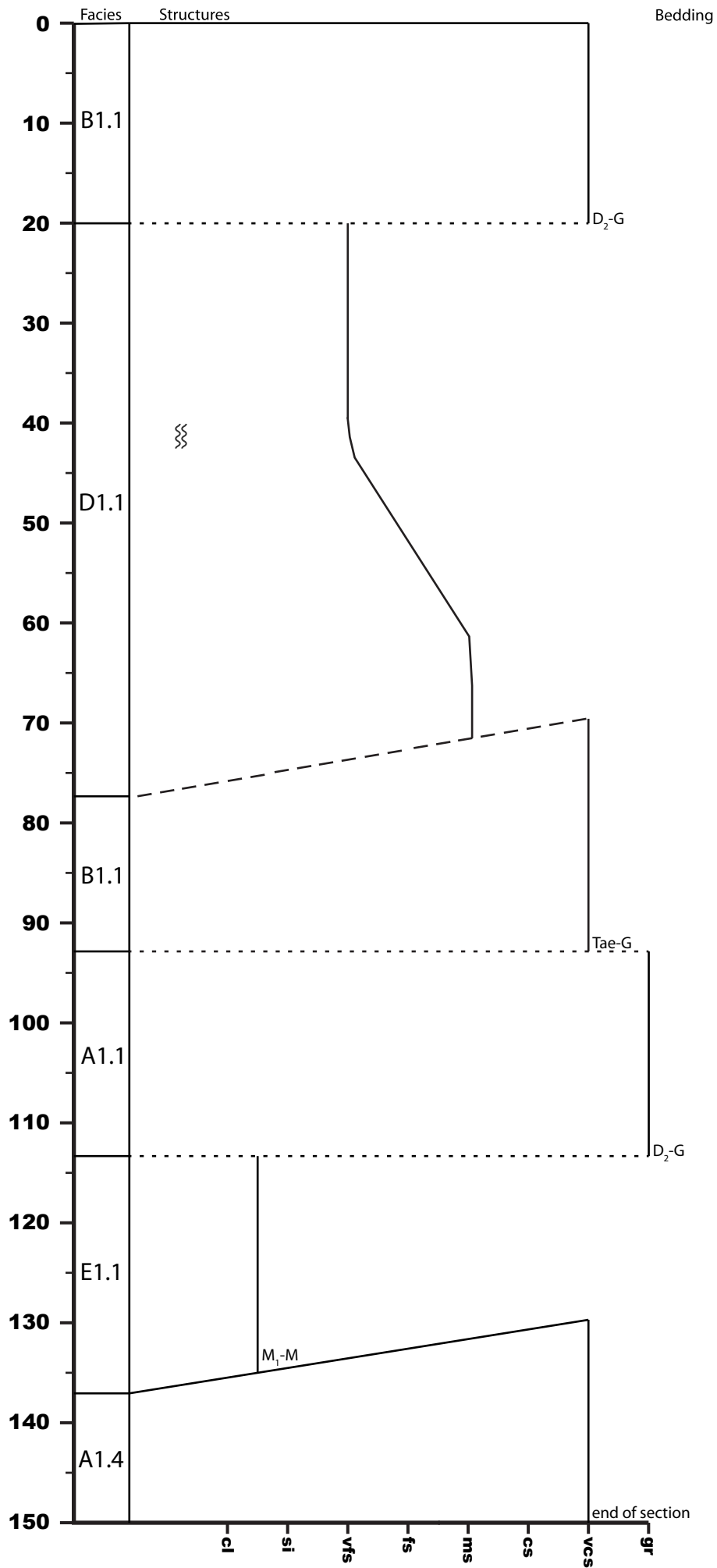

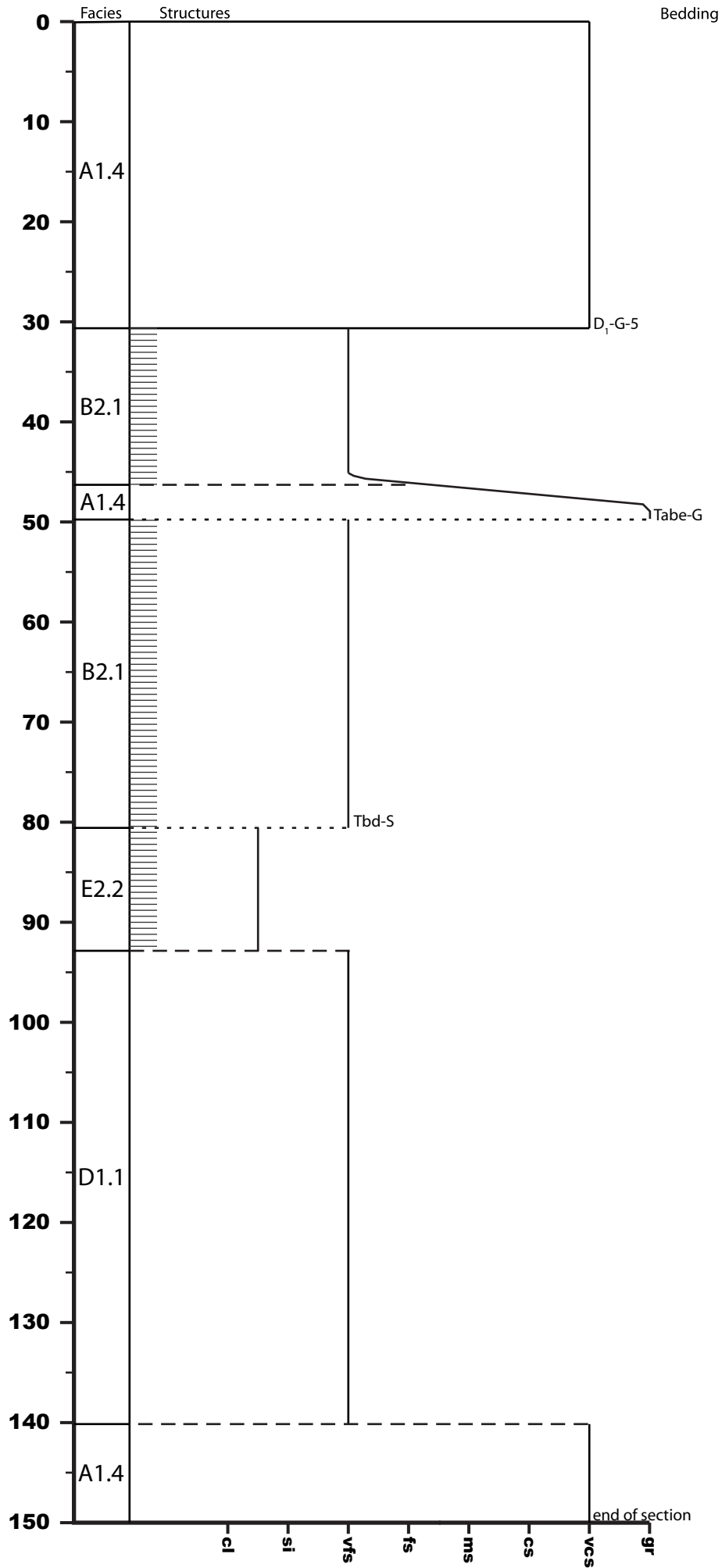

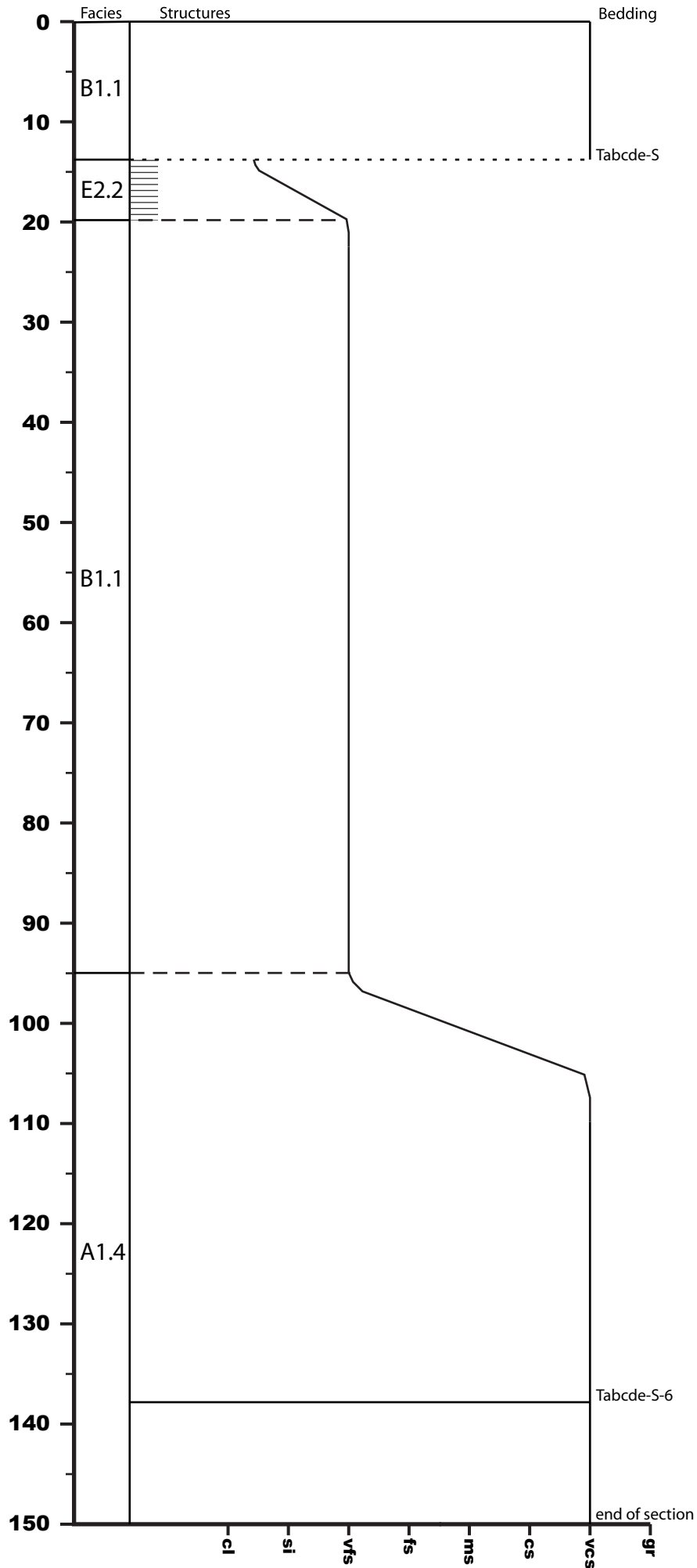

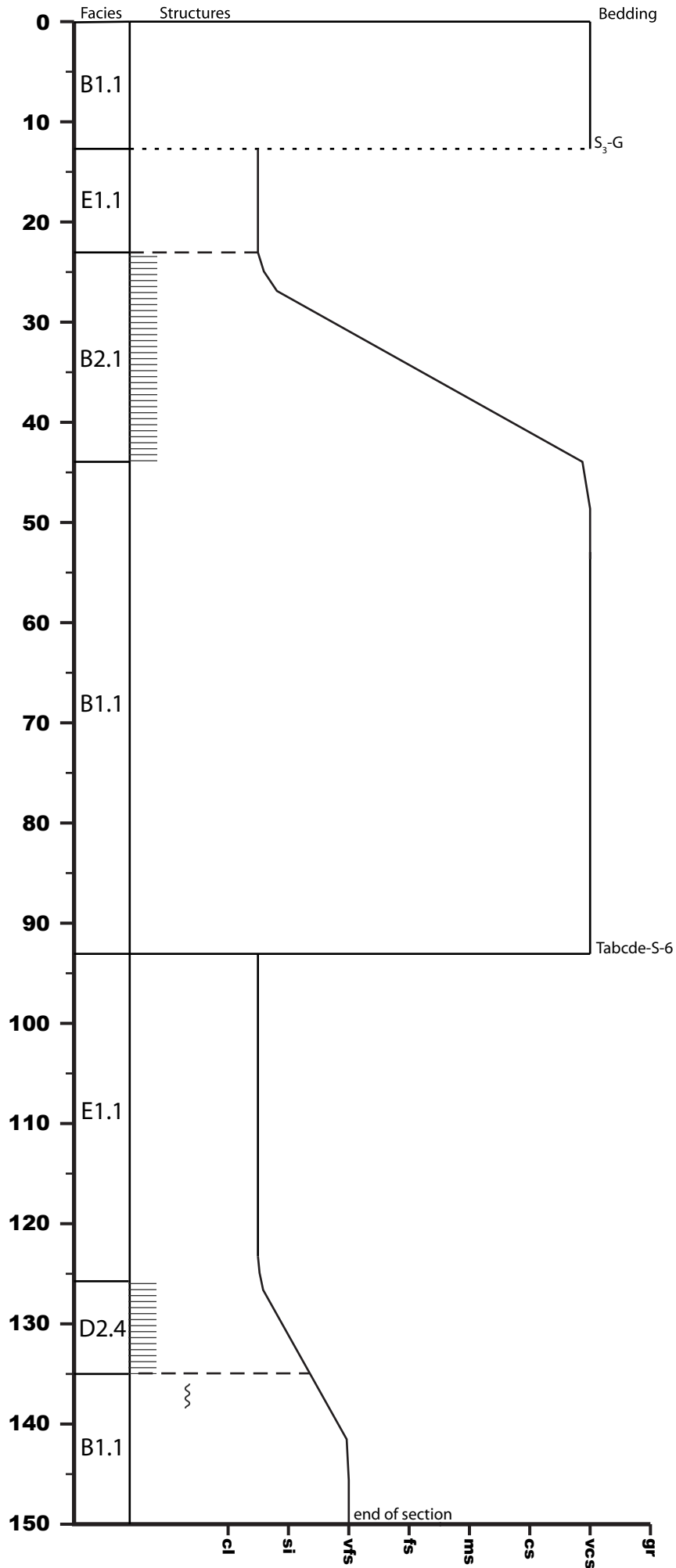



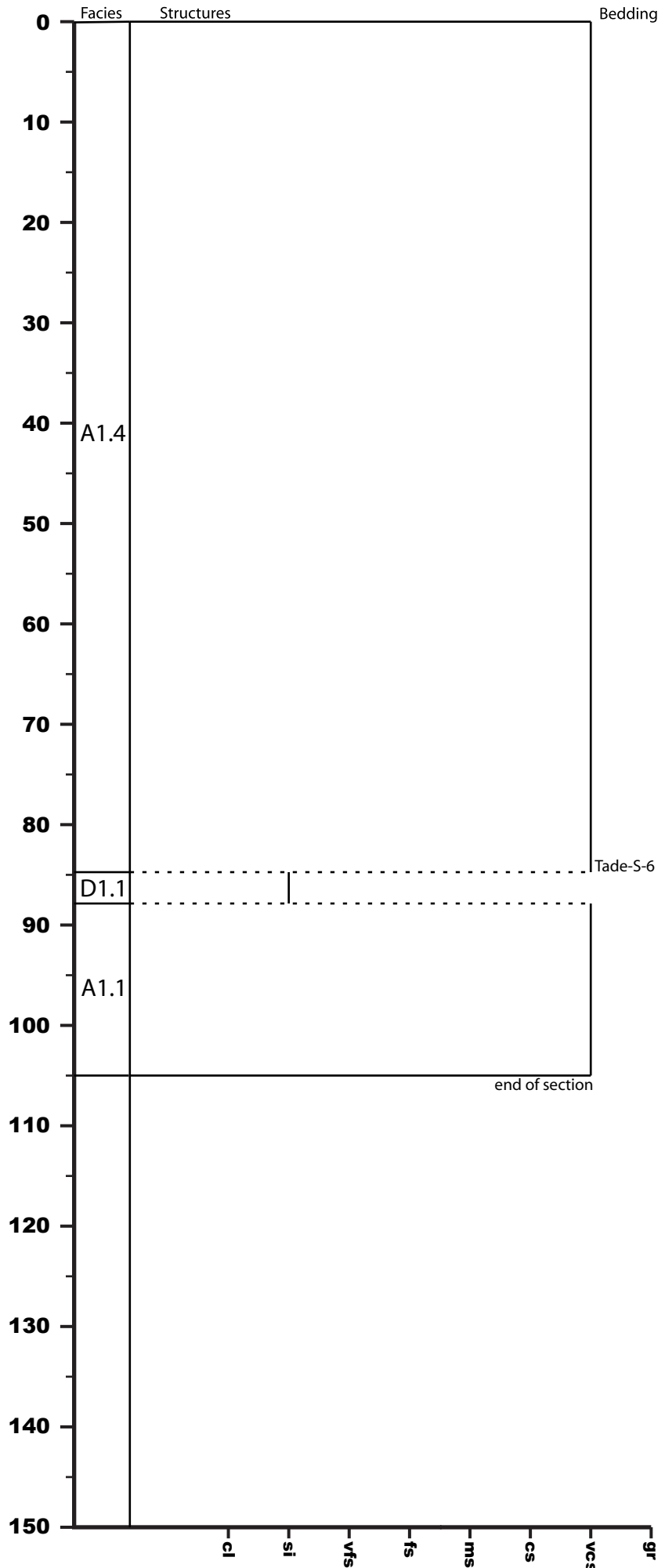

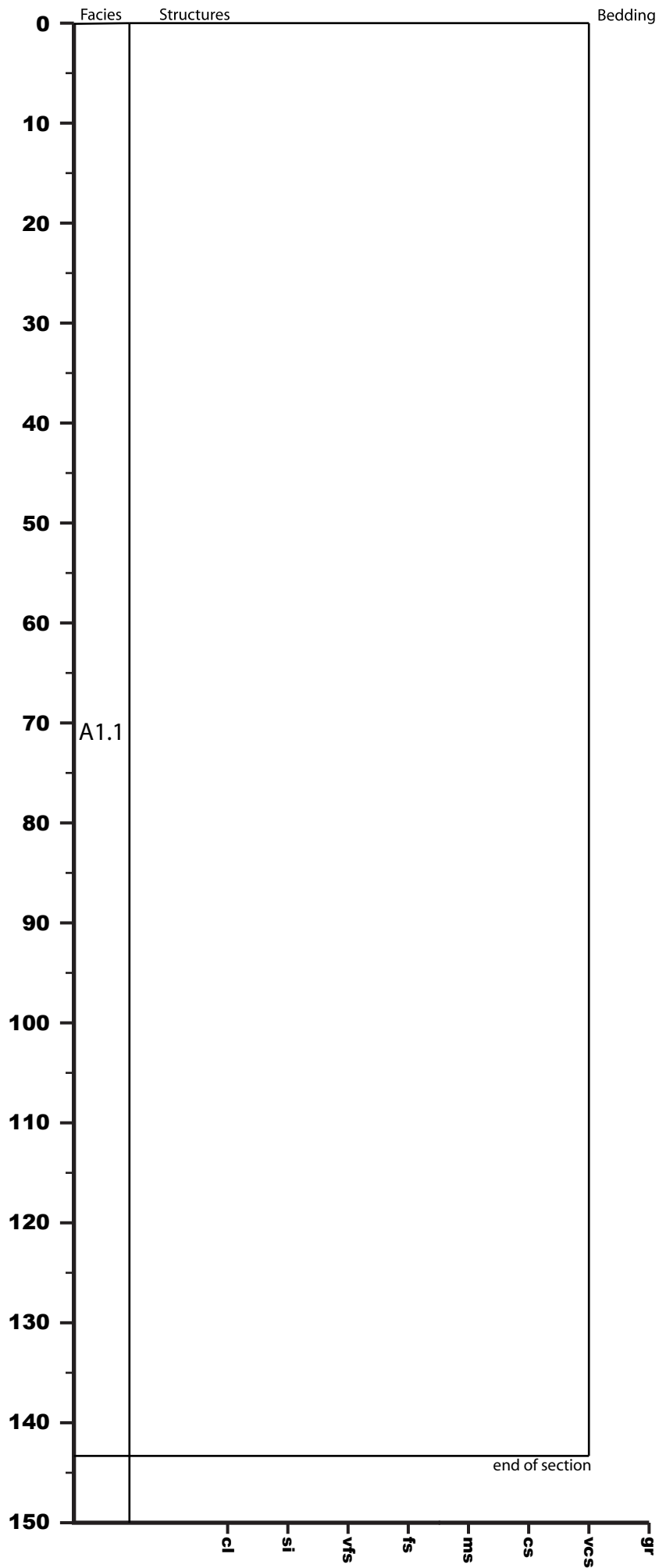

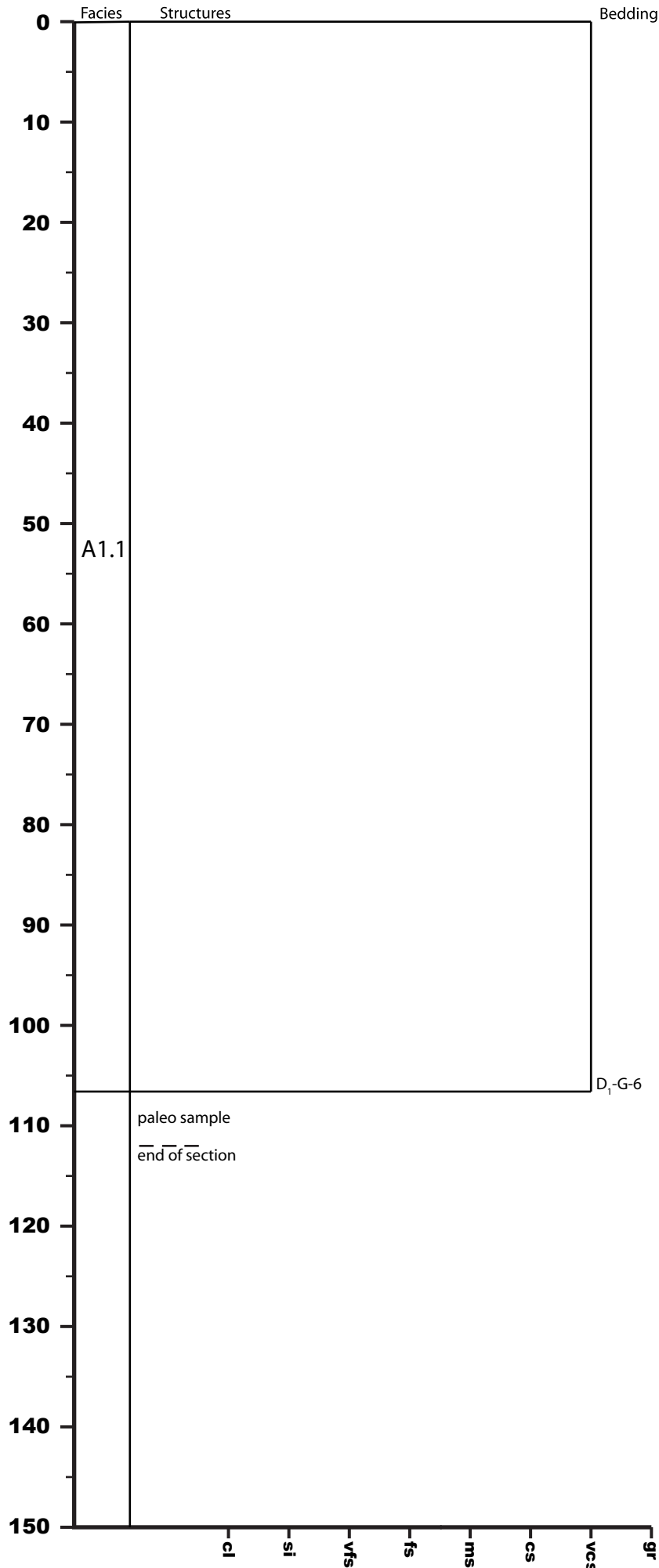

U1438E-34R-1

1158.1 - 1159.6 mbsf

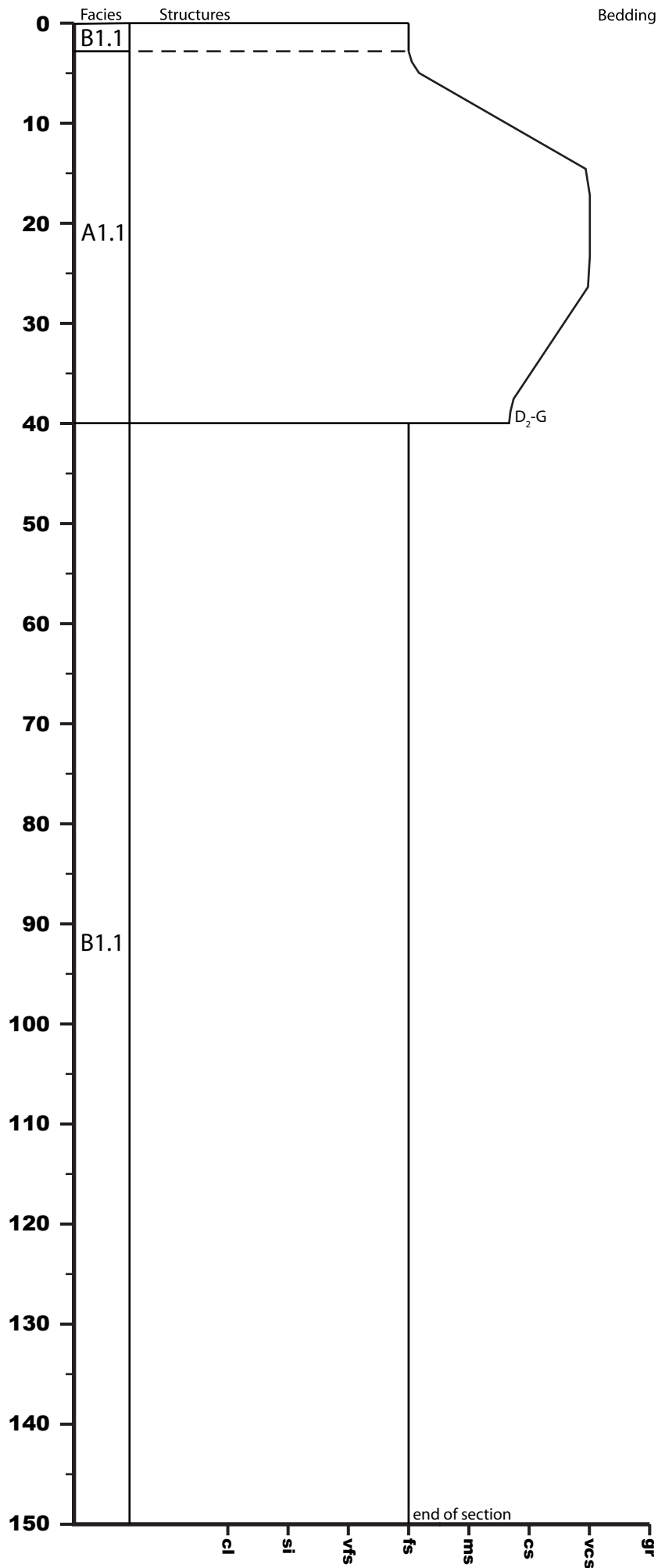

U1438E-34R-2

1159.6 - 1160.83 mbsf

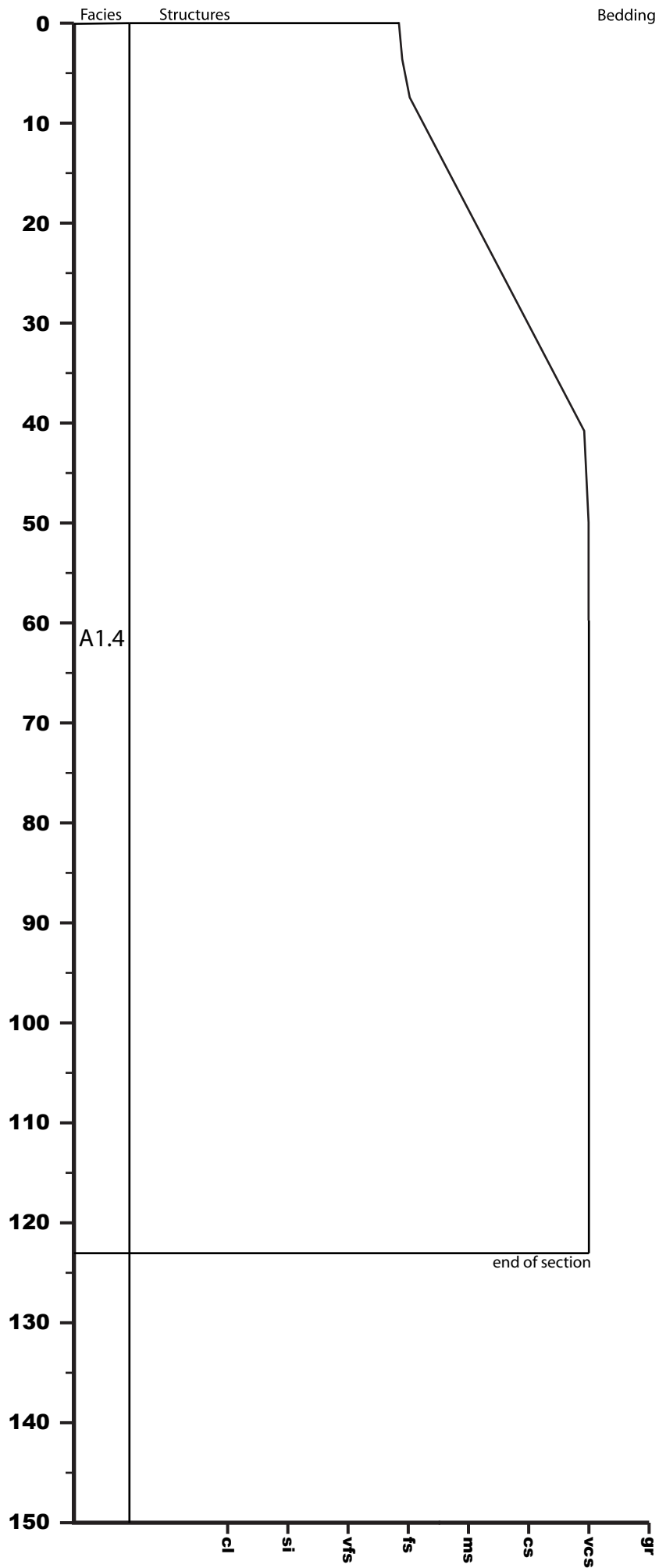

U1438E-34R-3

1160.83 - 1162.33 mbsf

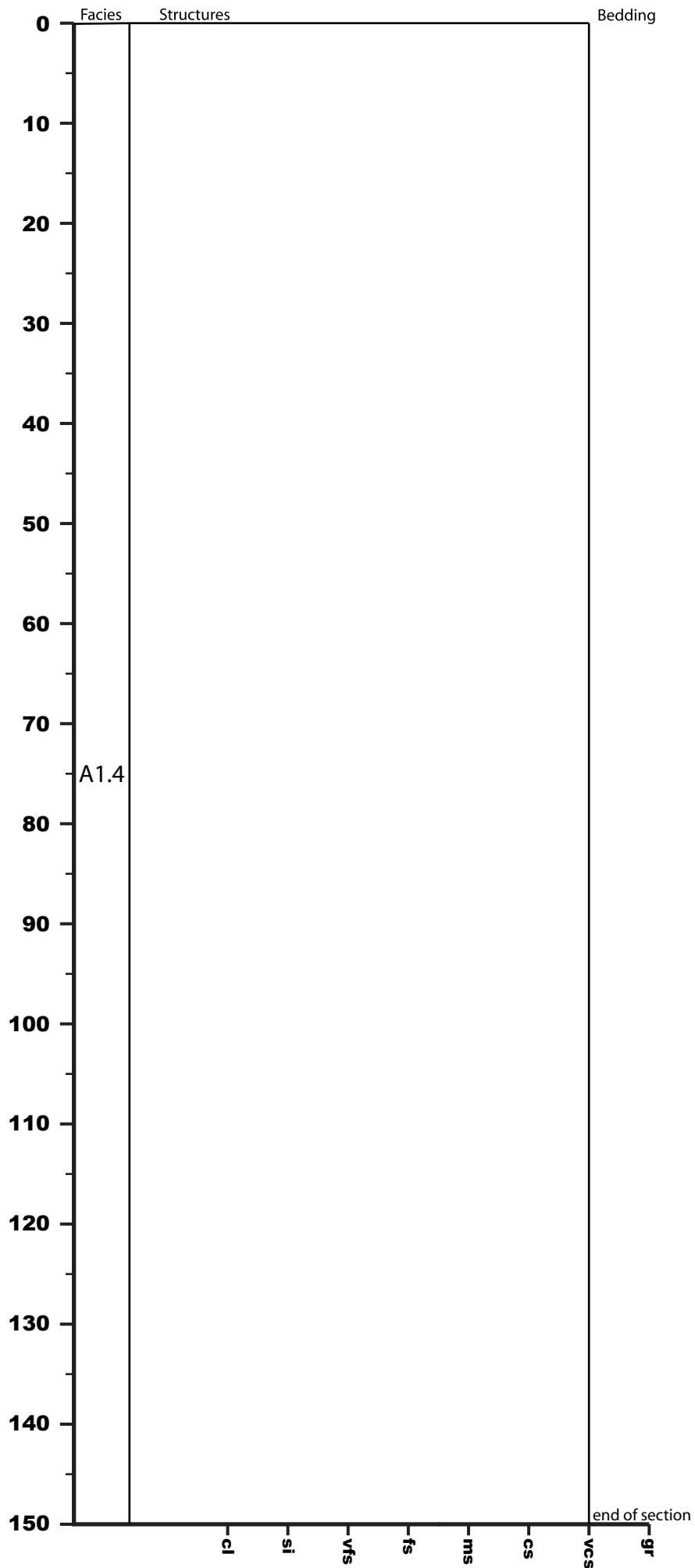

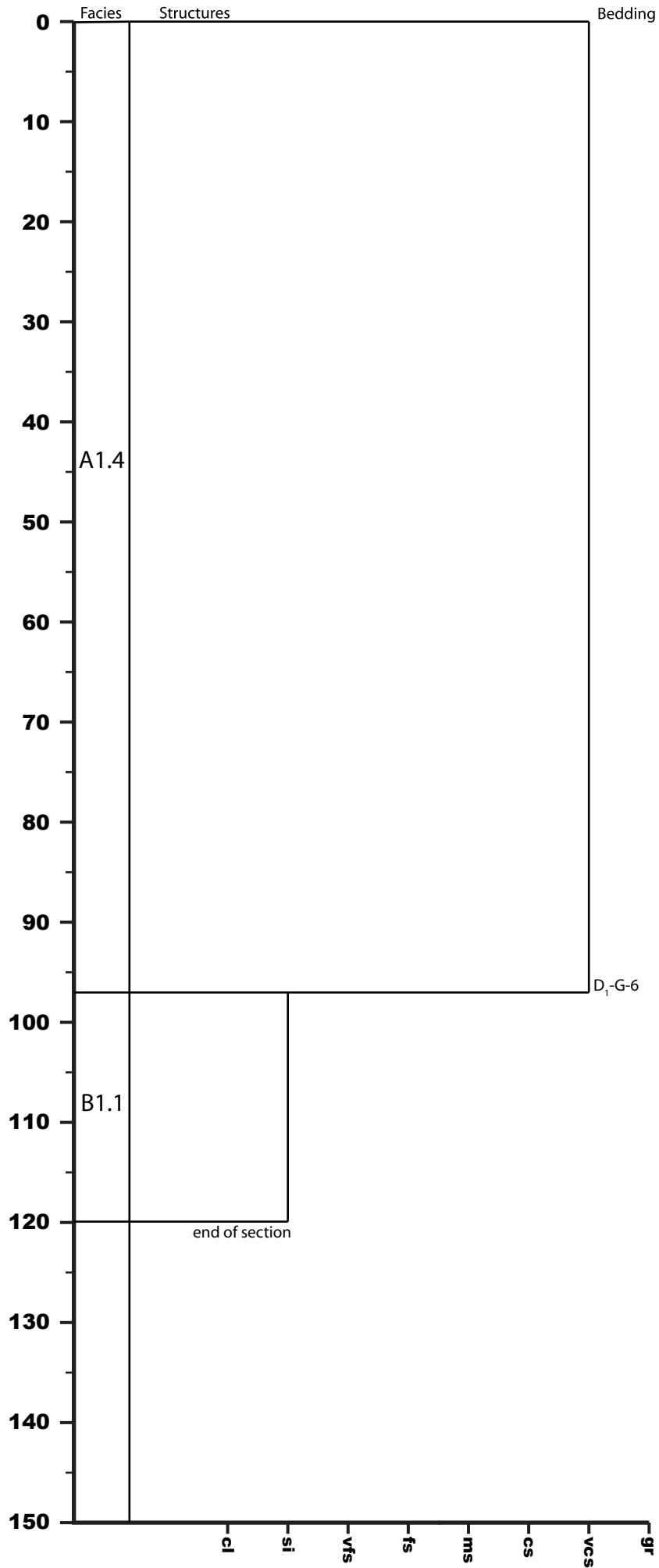

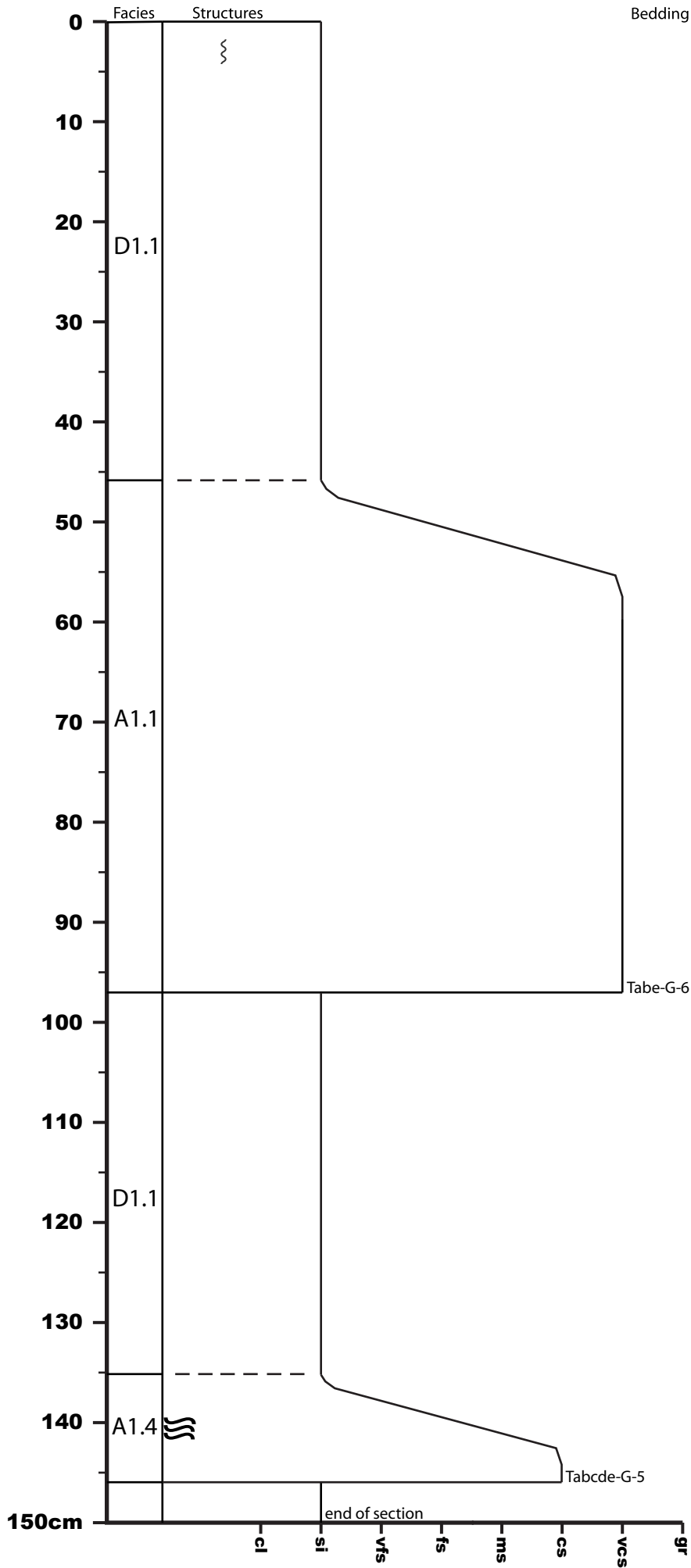



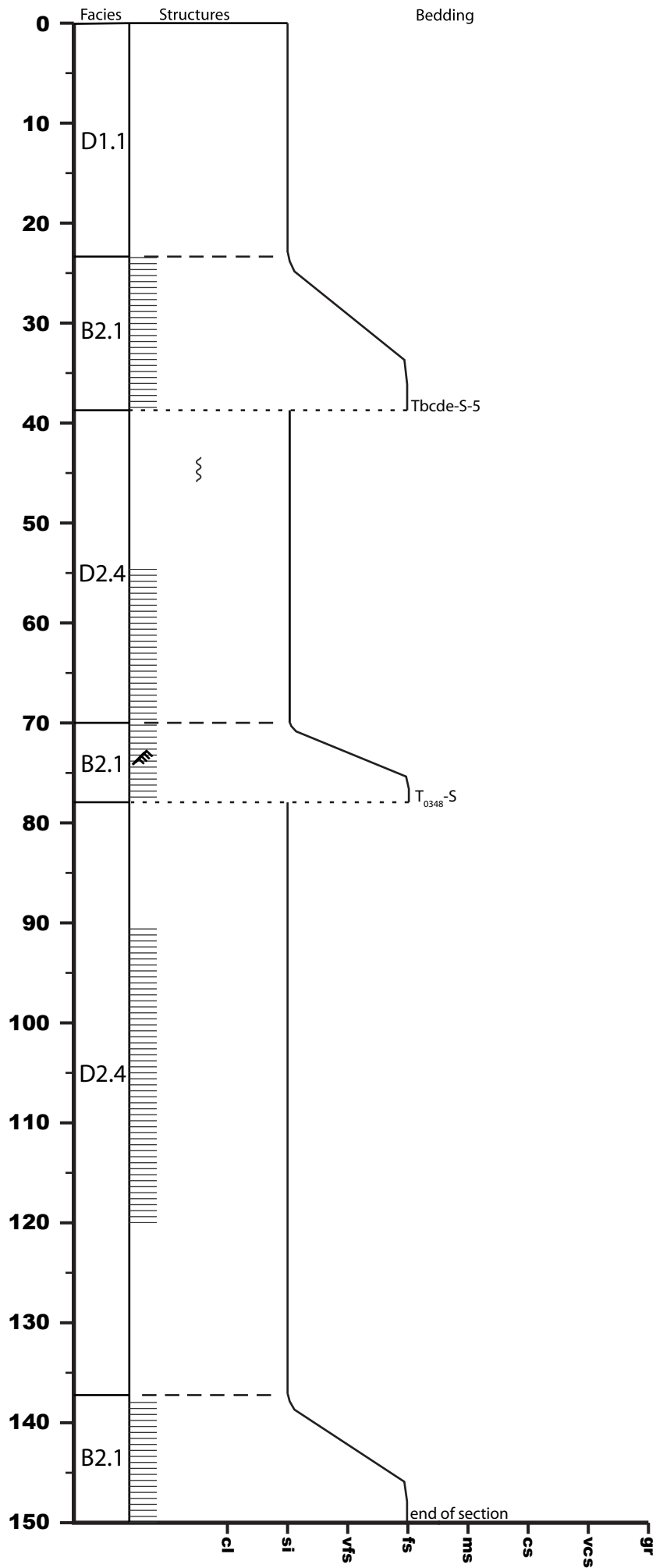

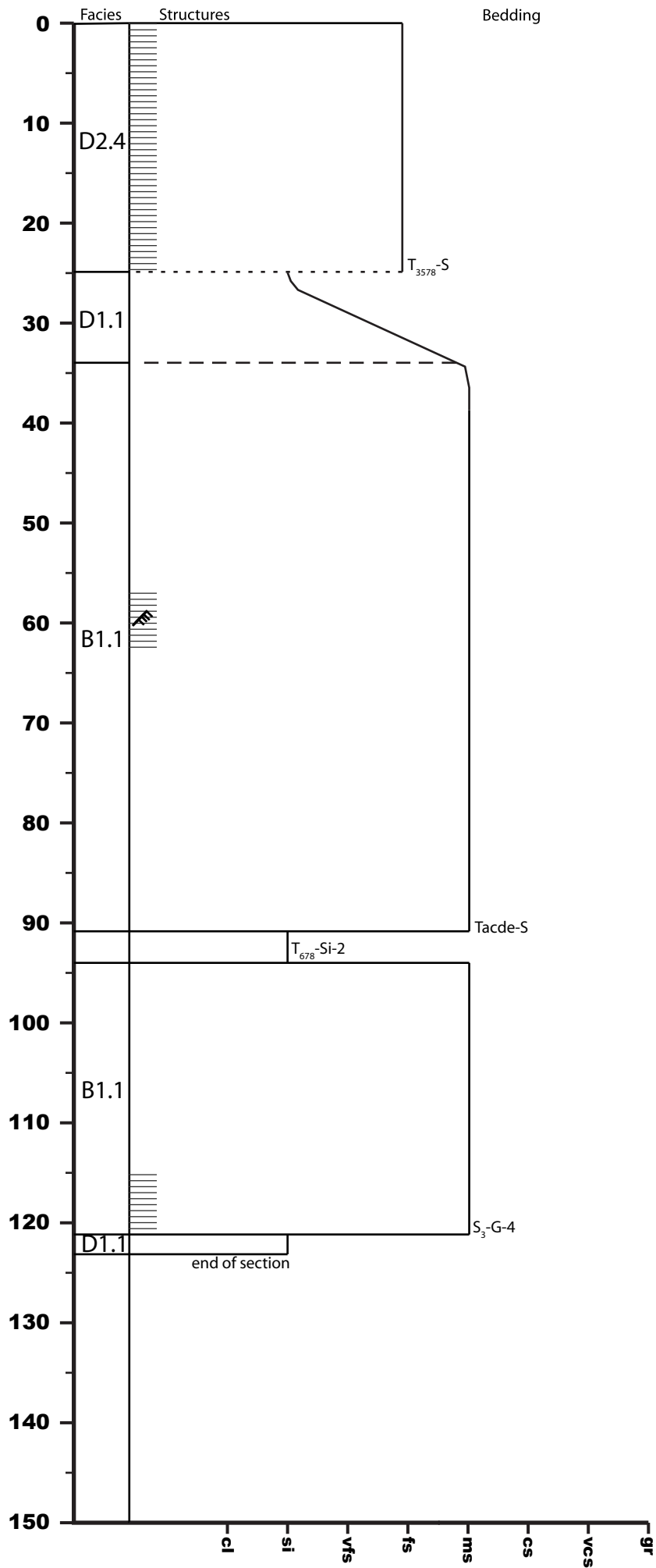

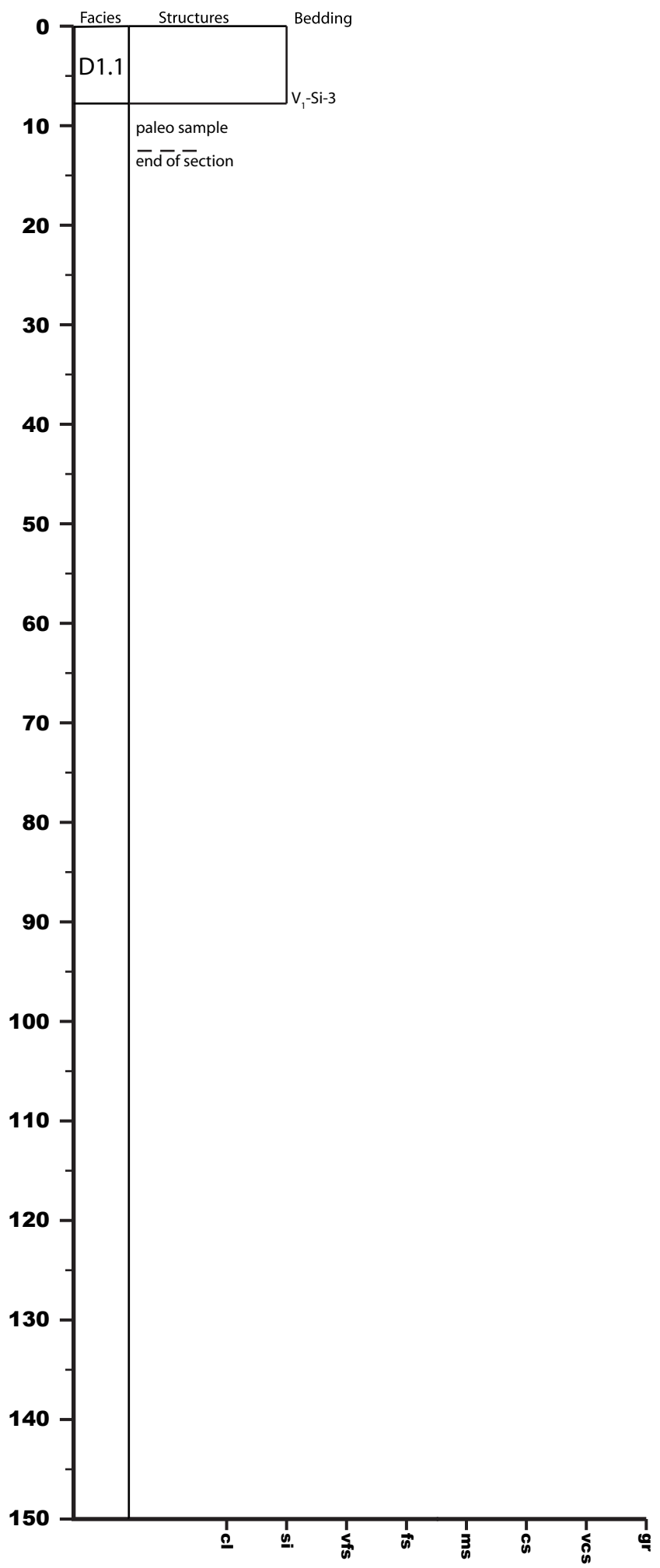

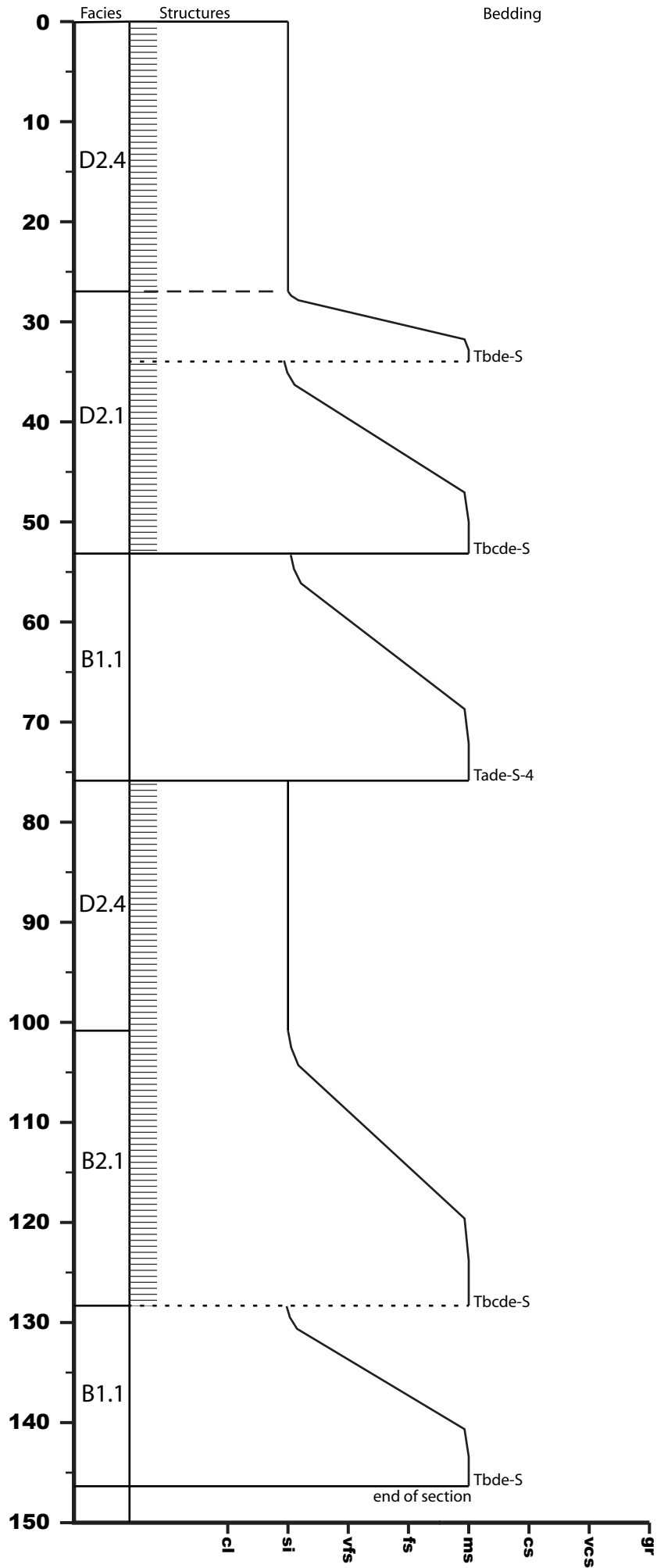

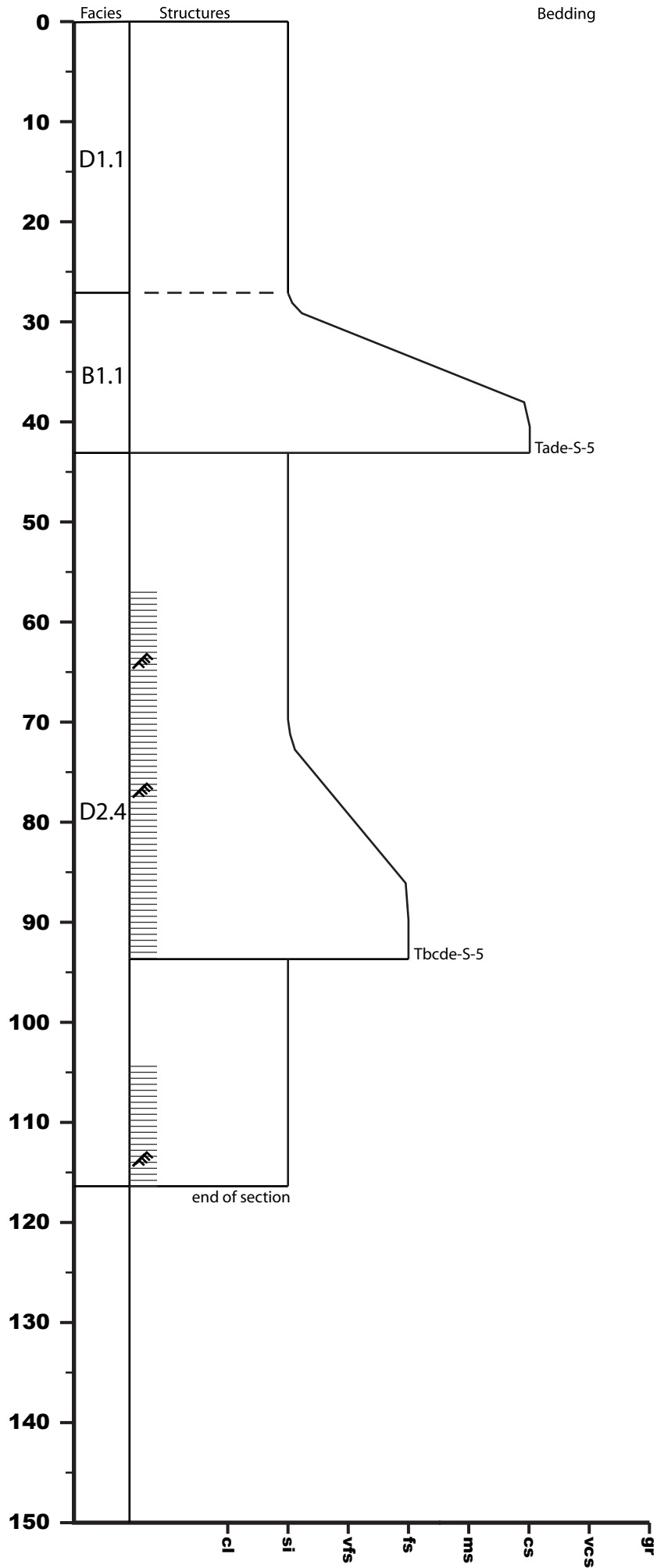

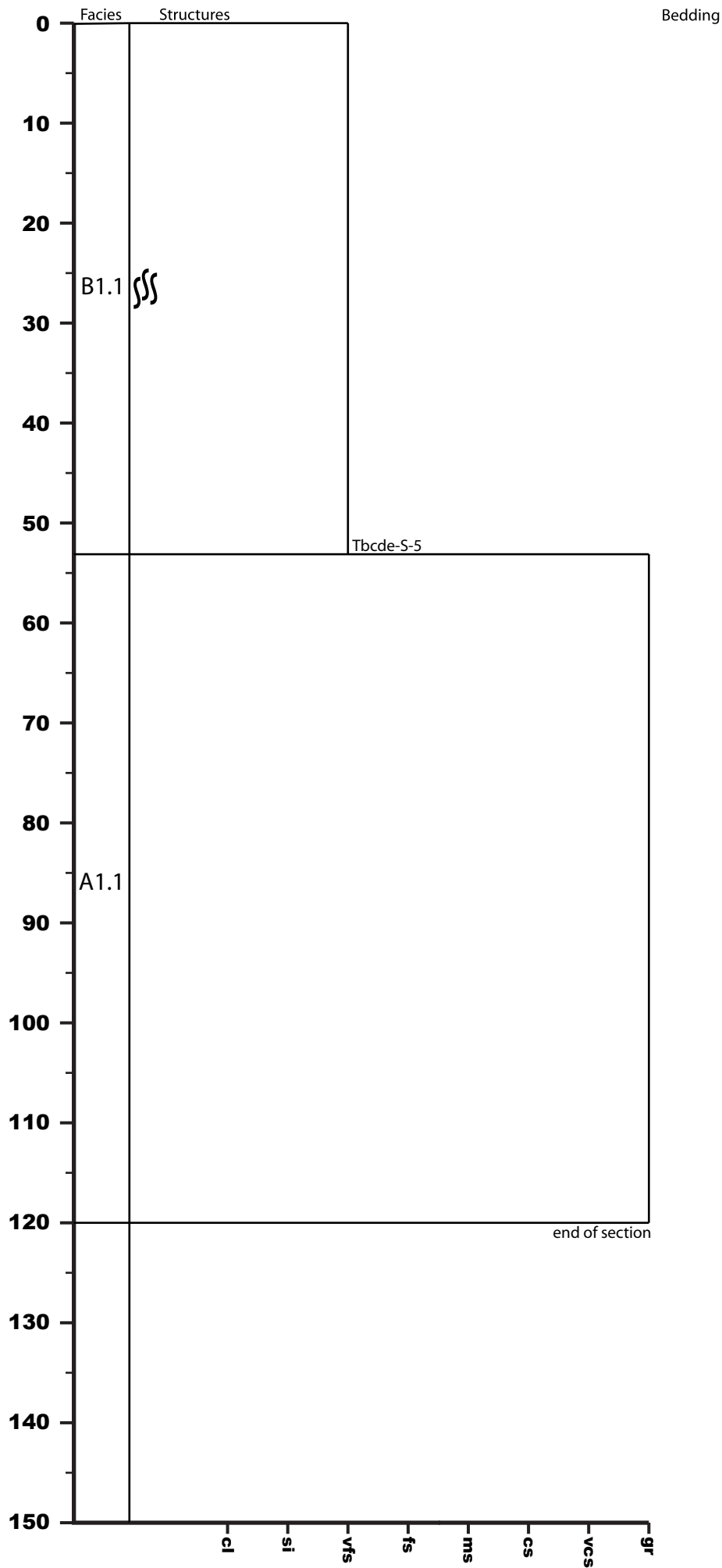

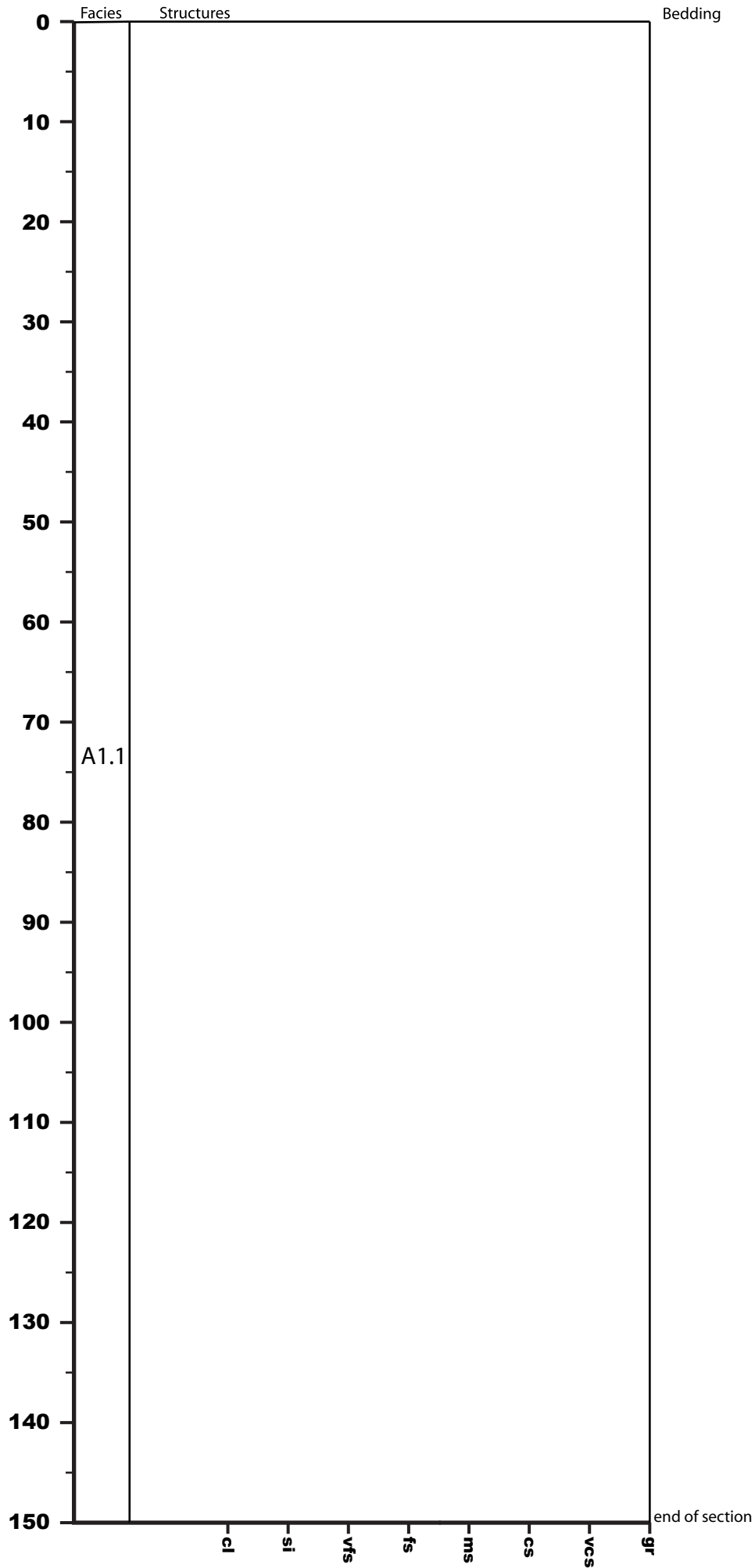

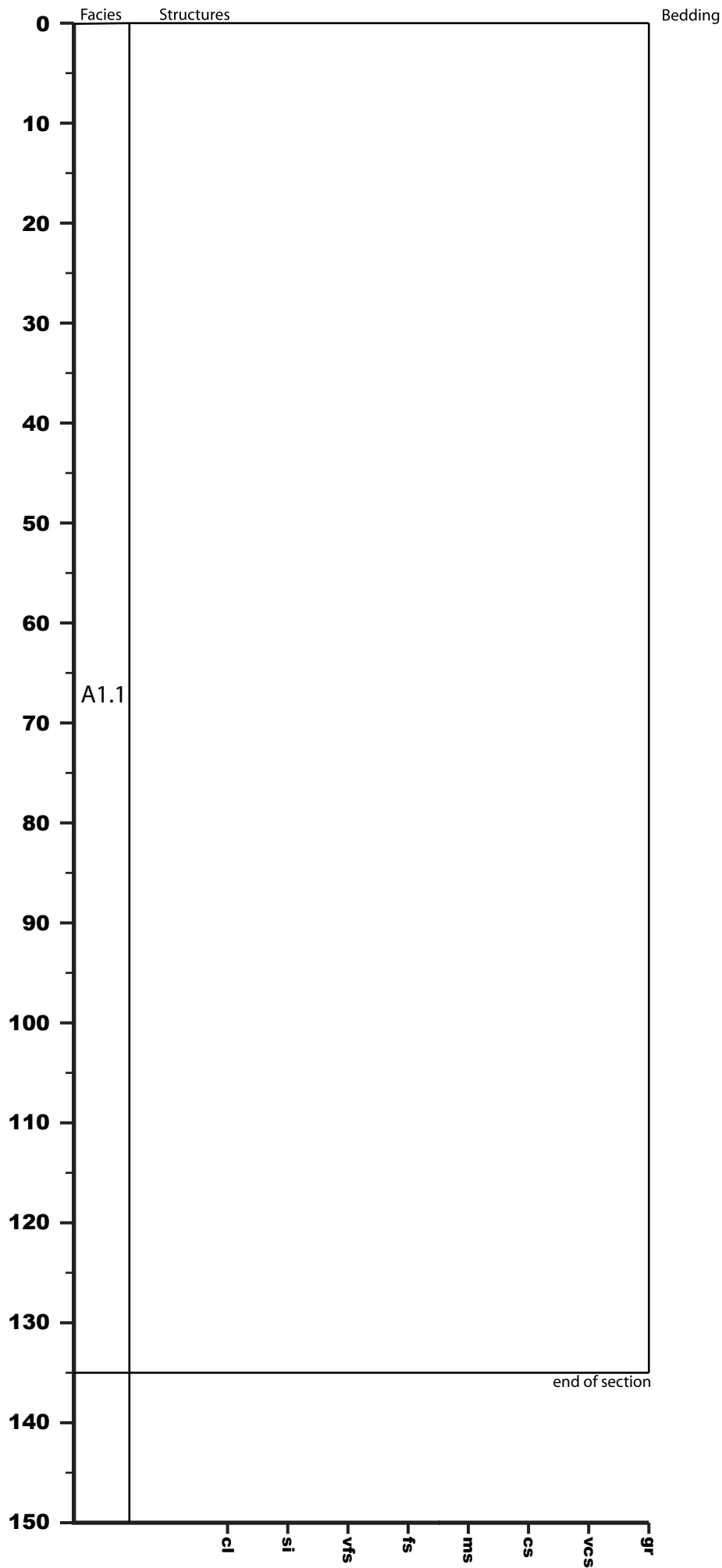



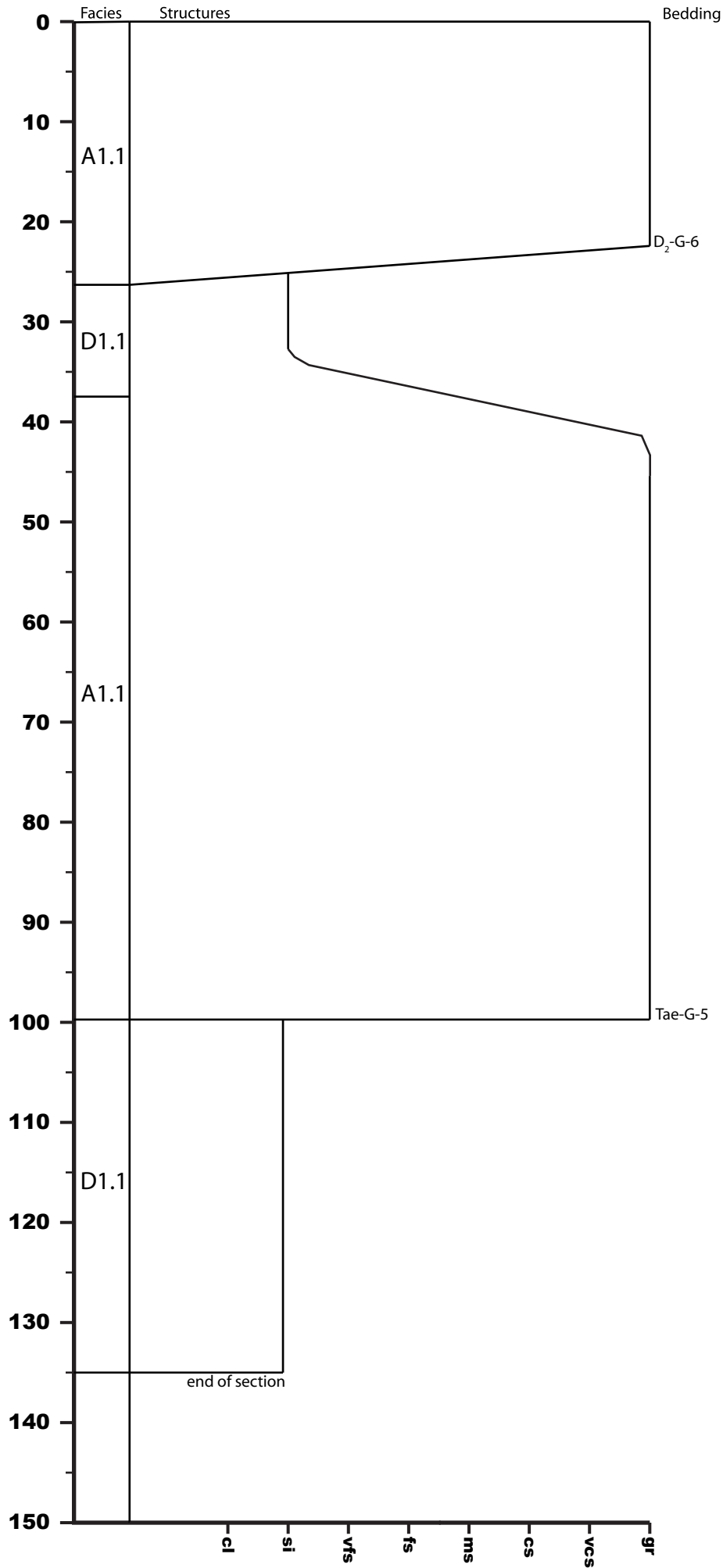

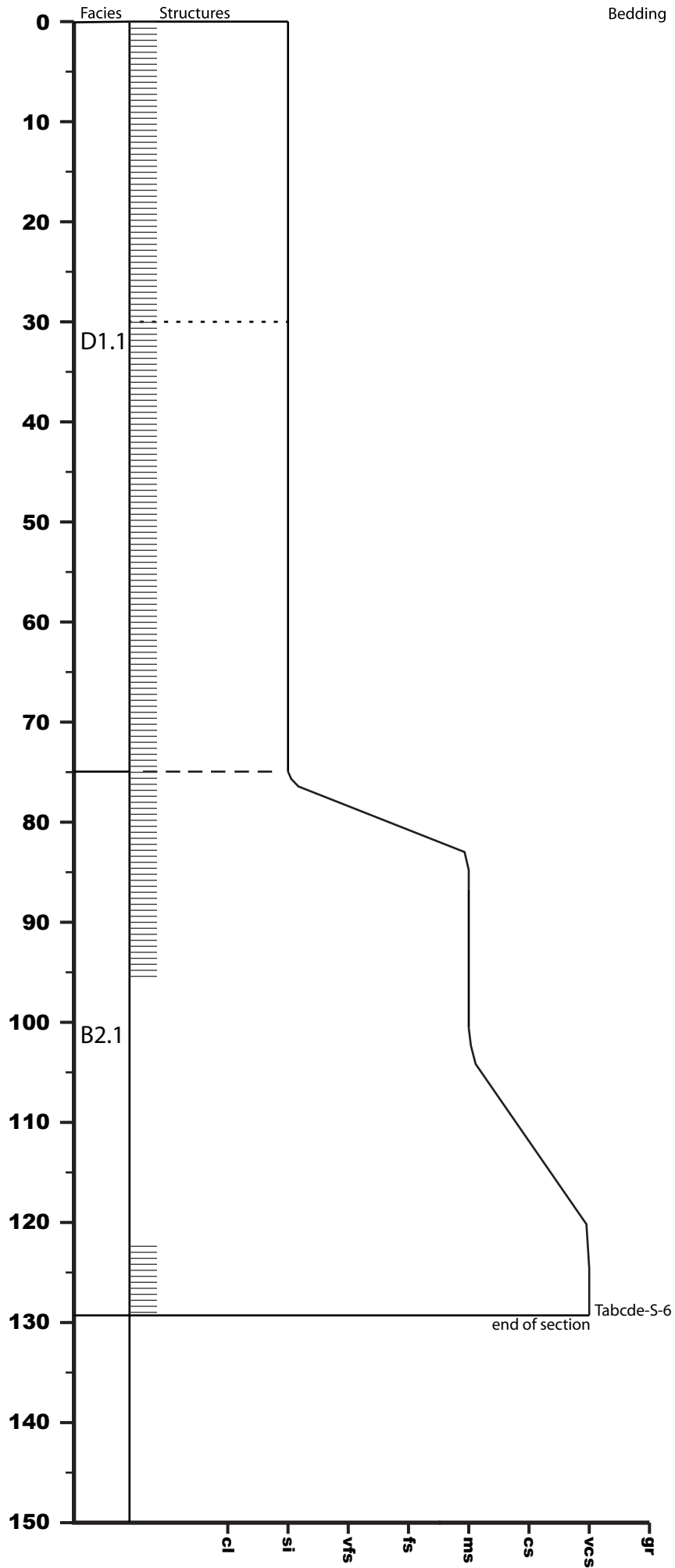

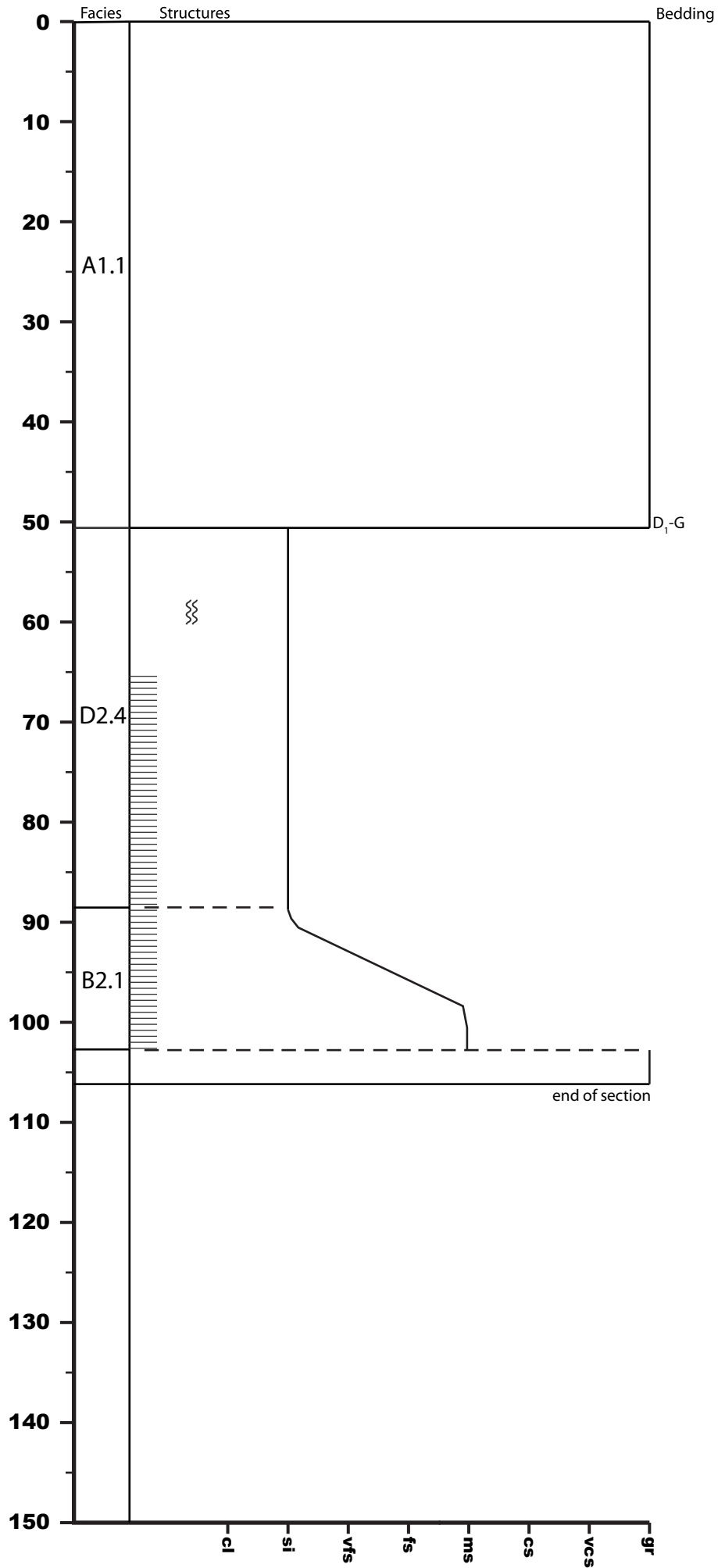

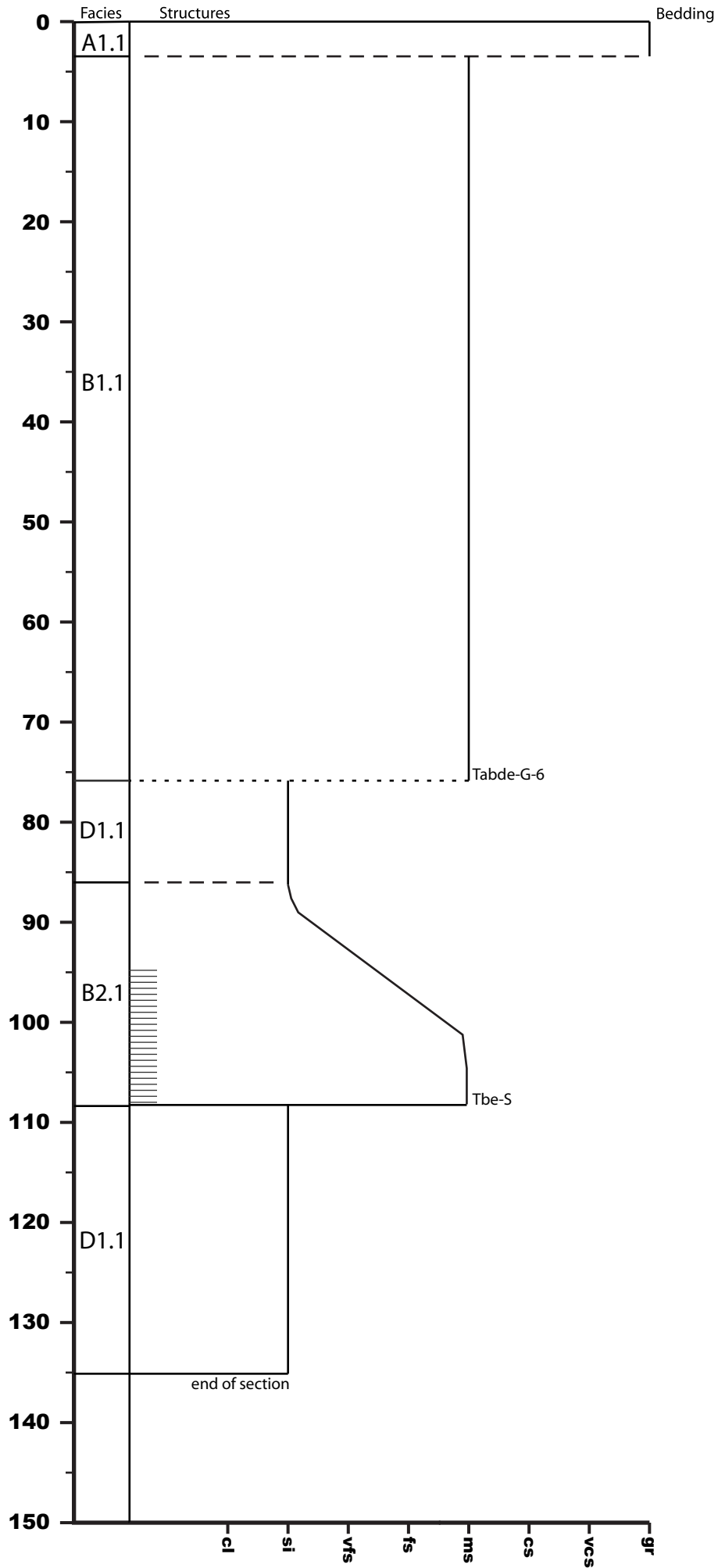

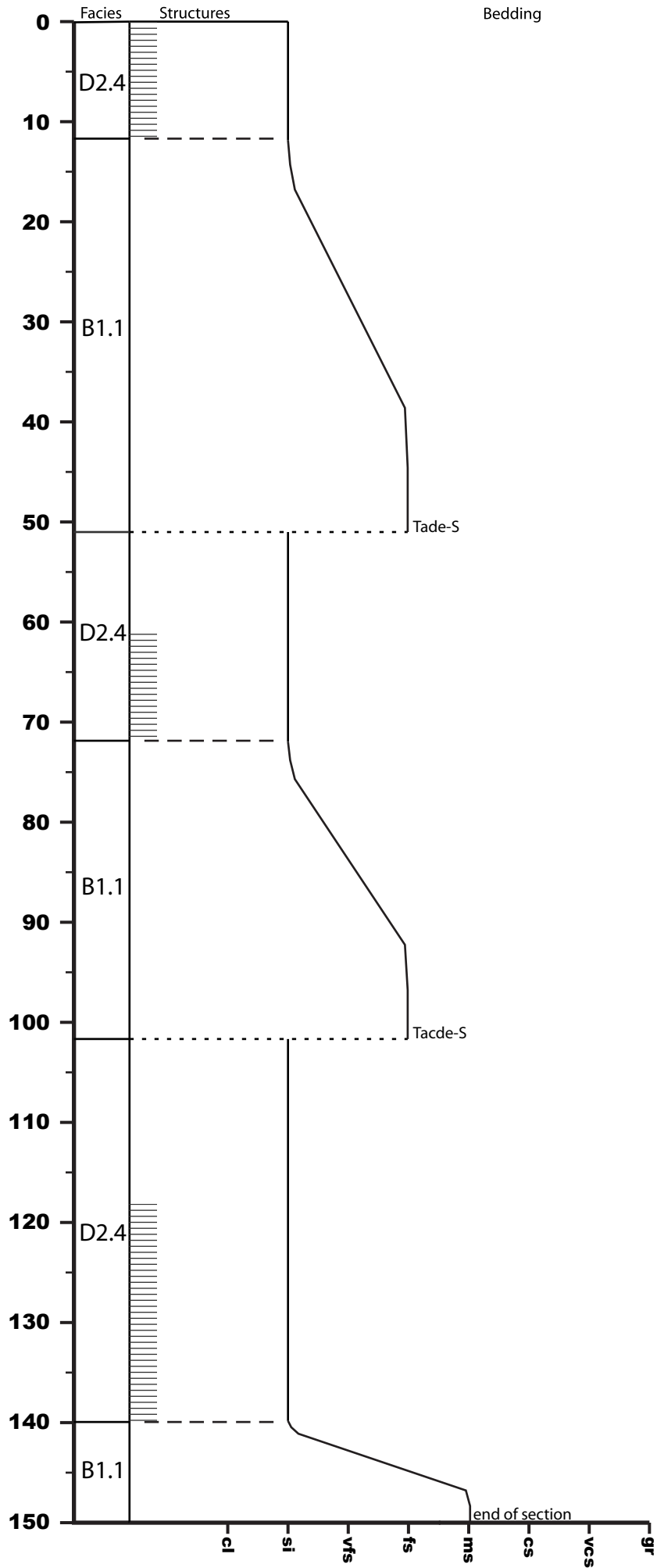

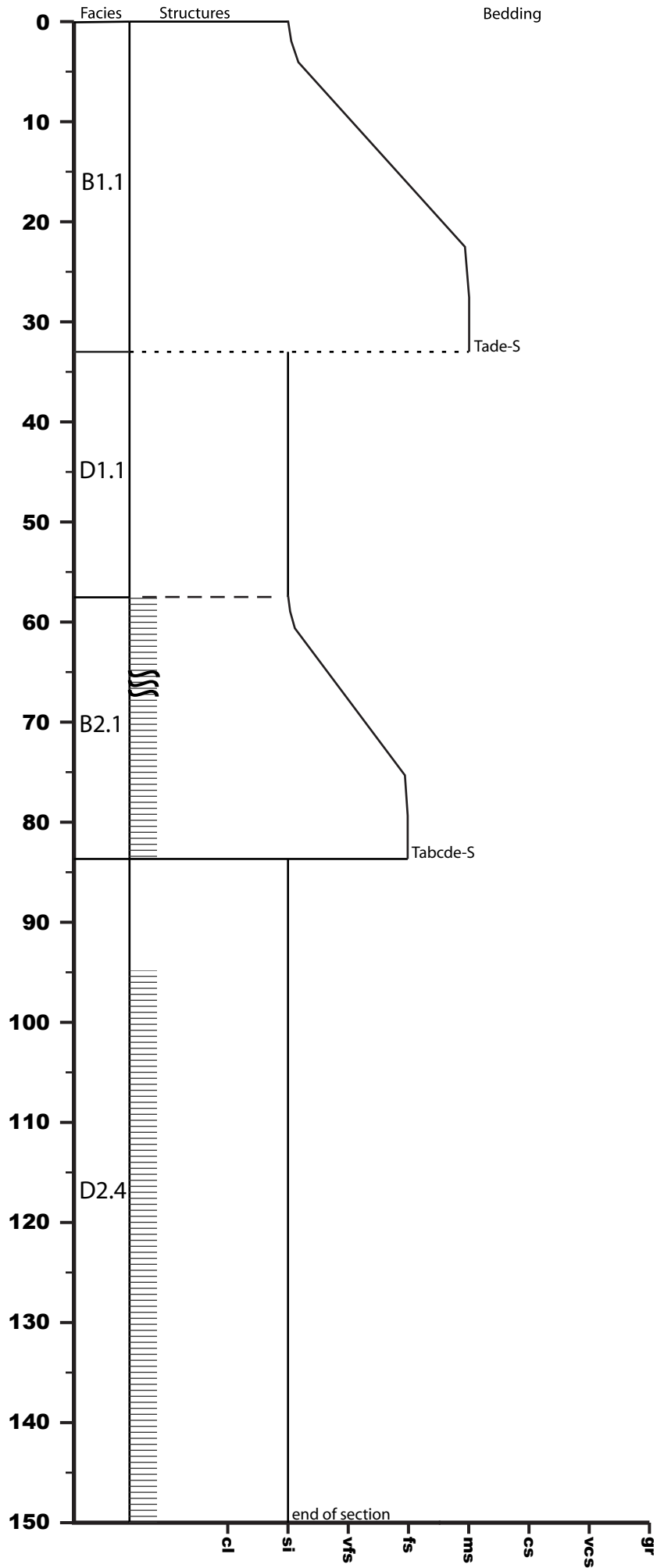

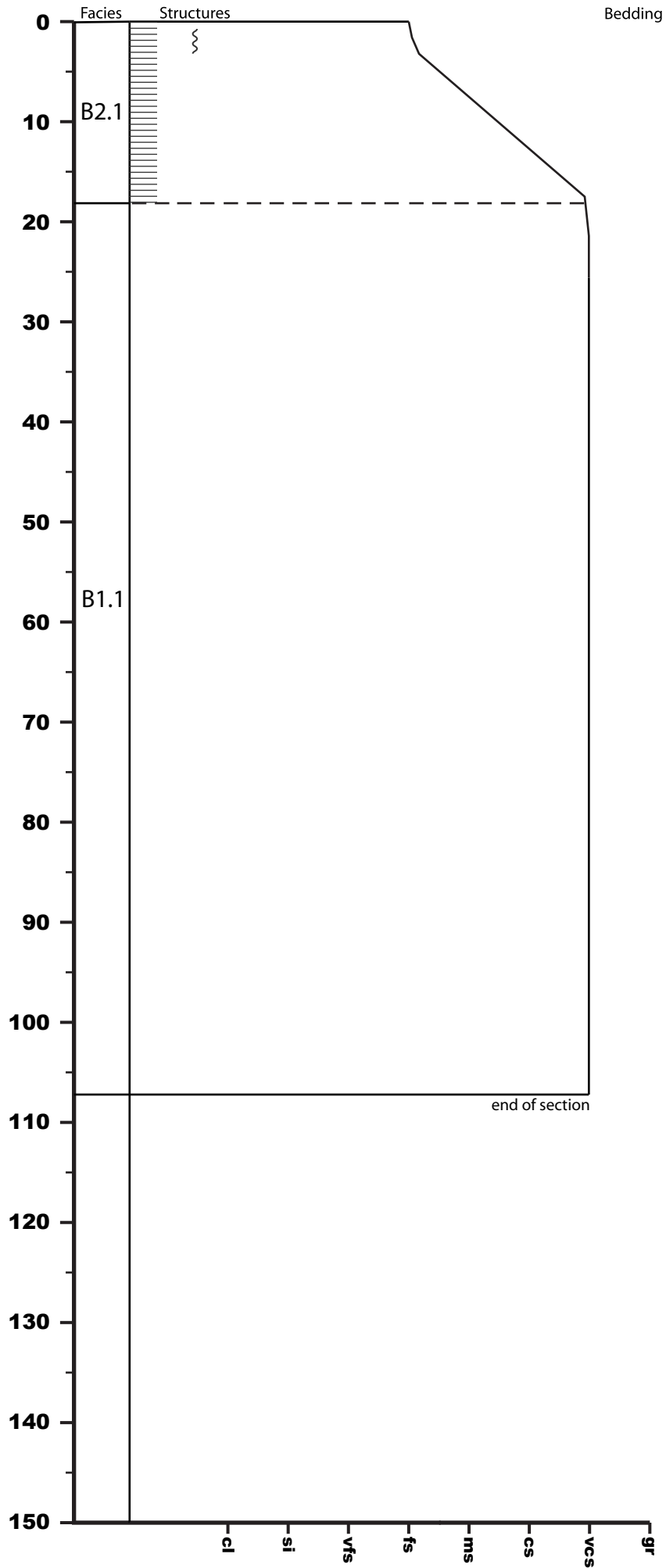

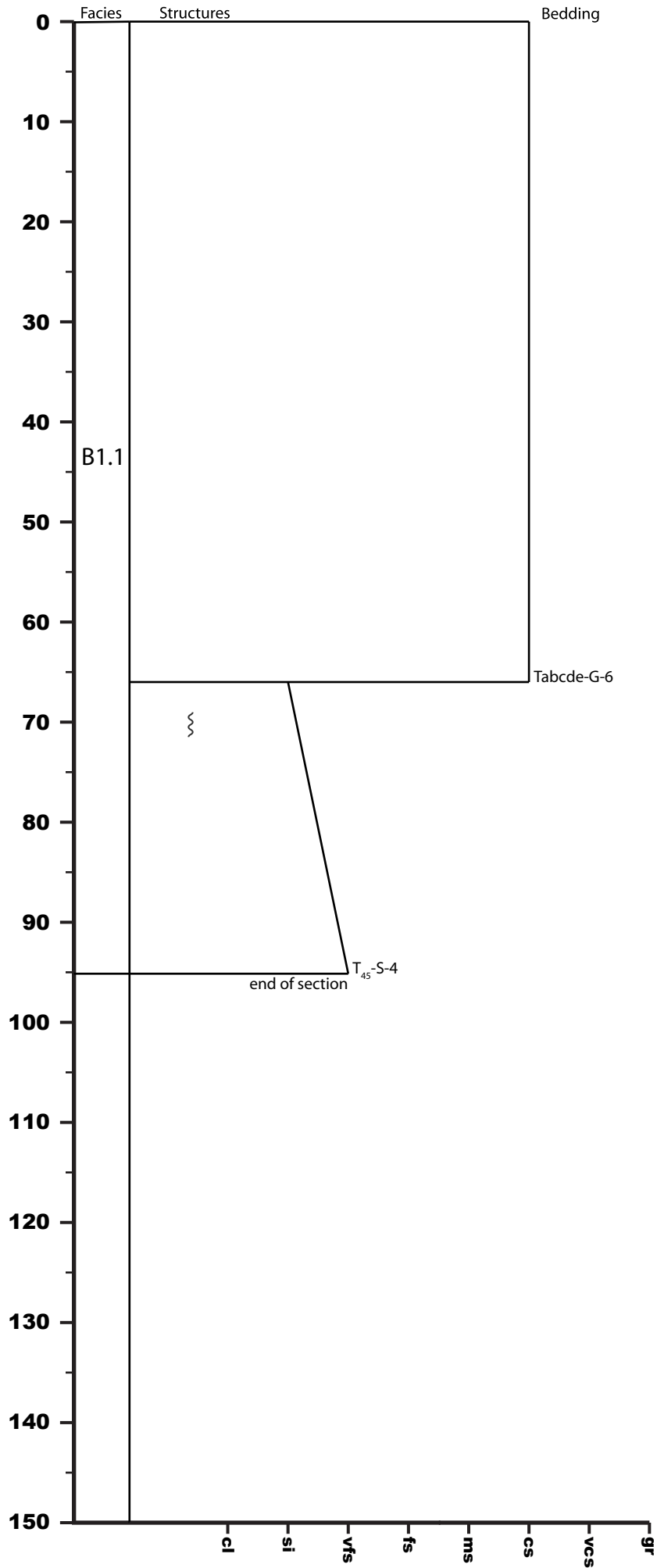



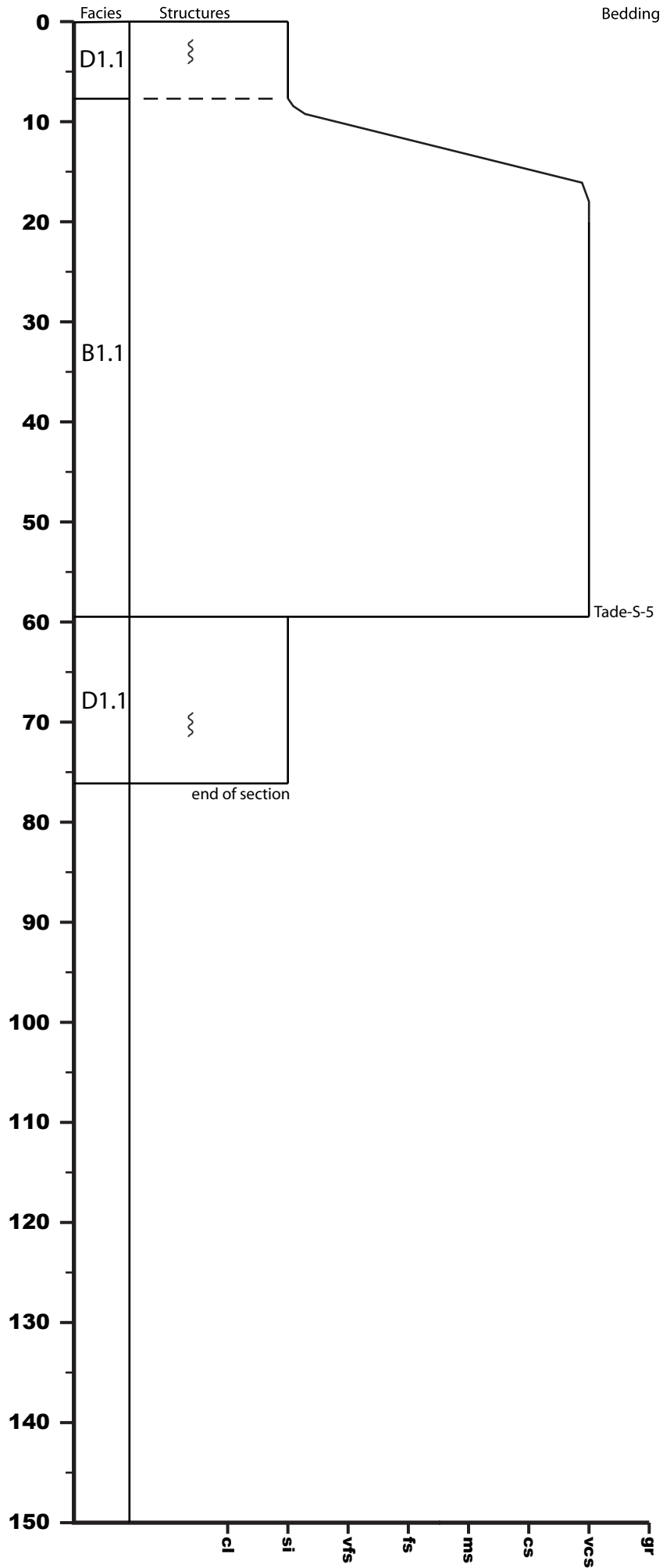

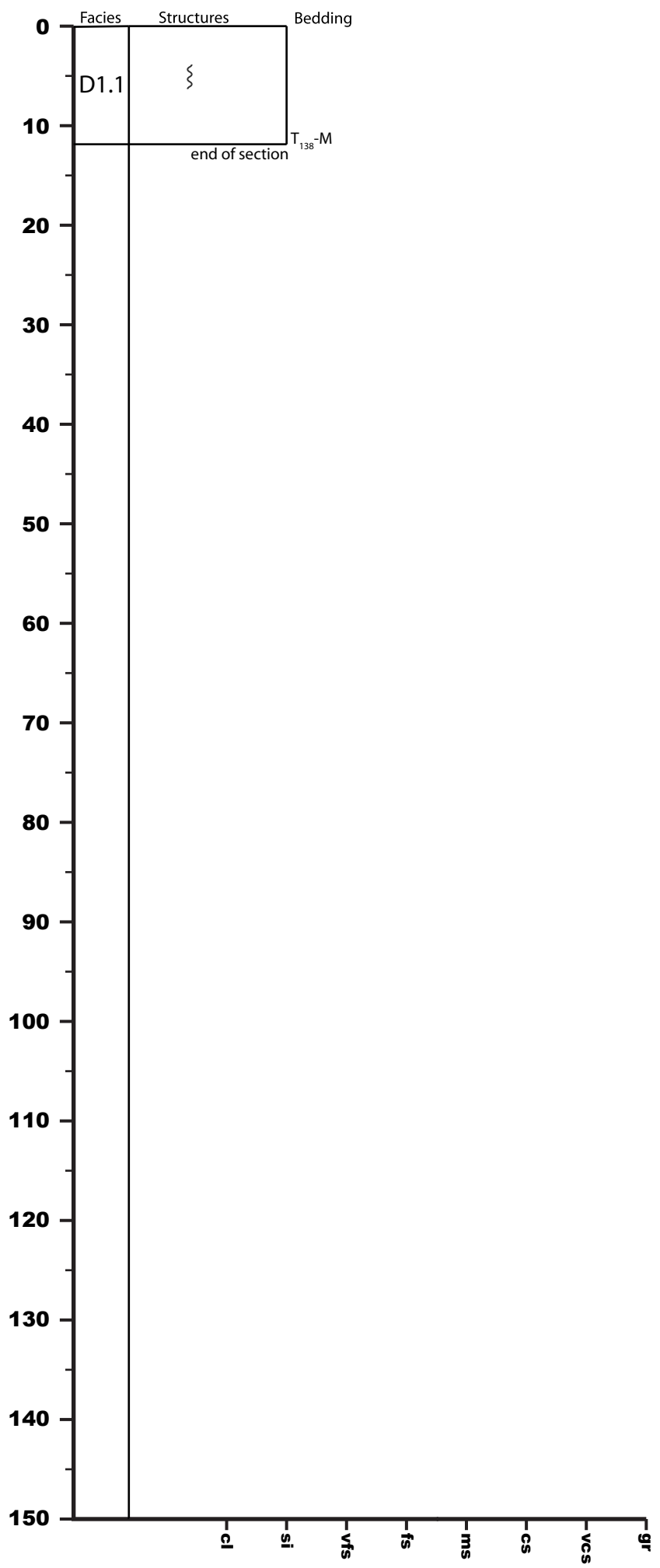

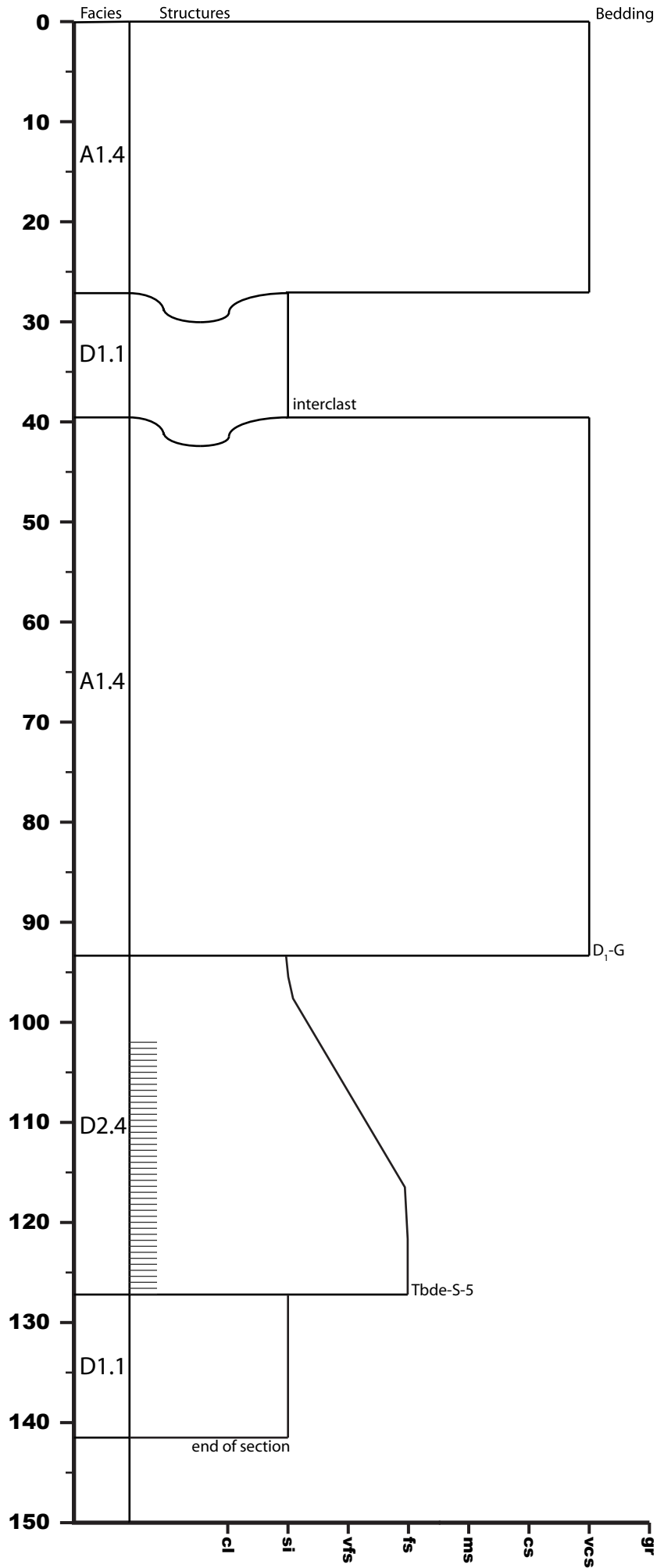

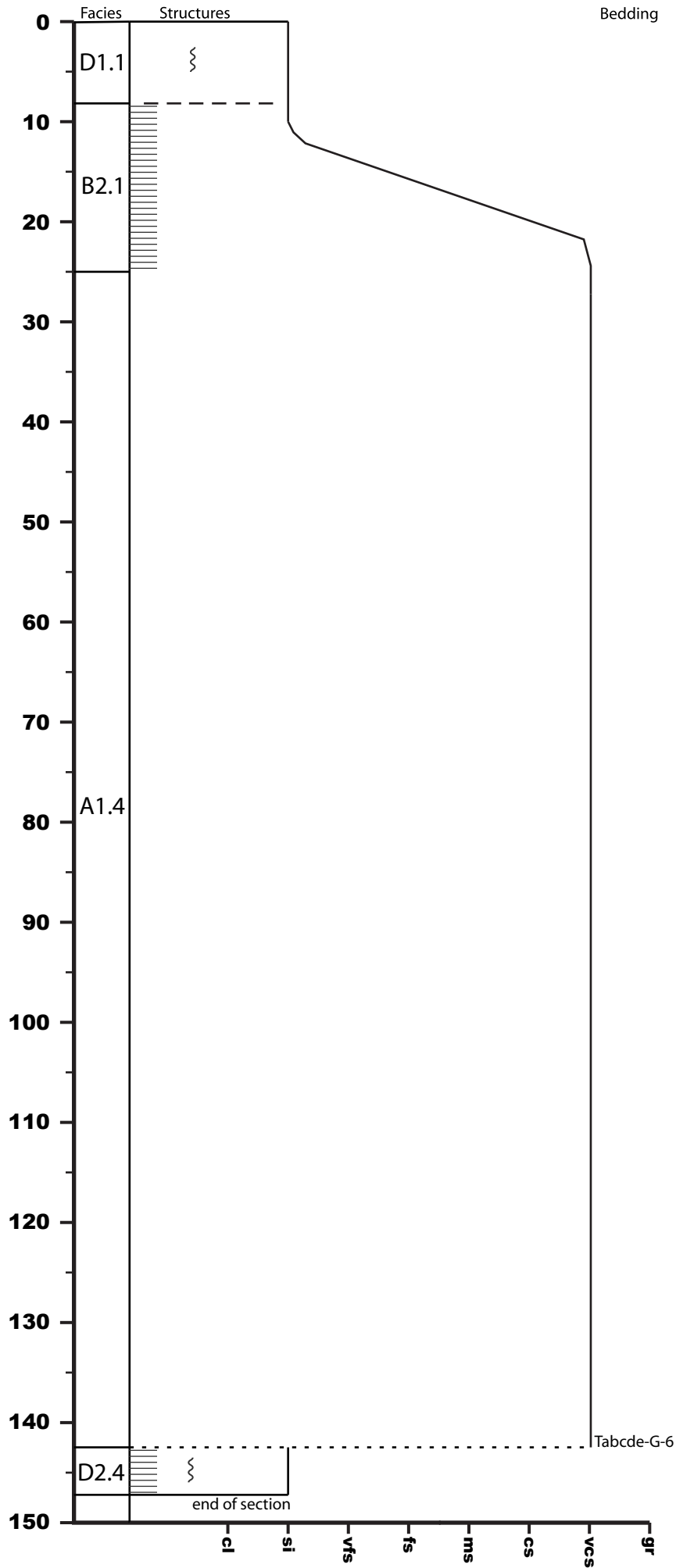

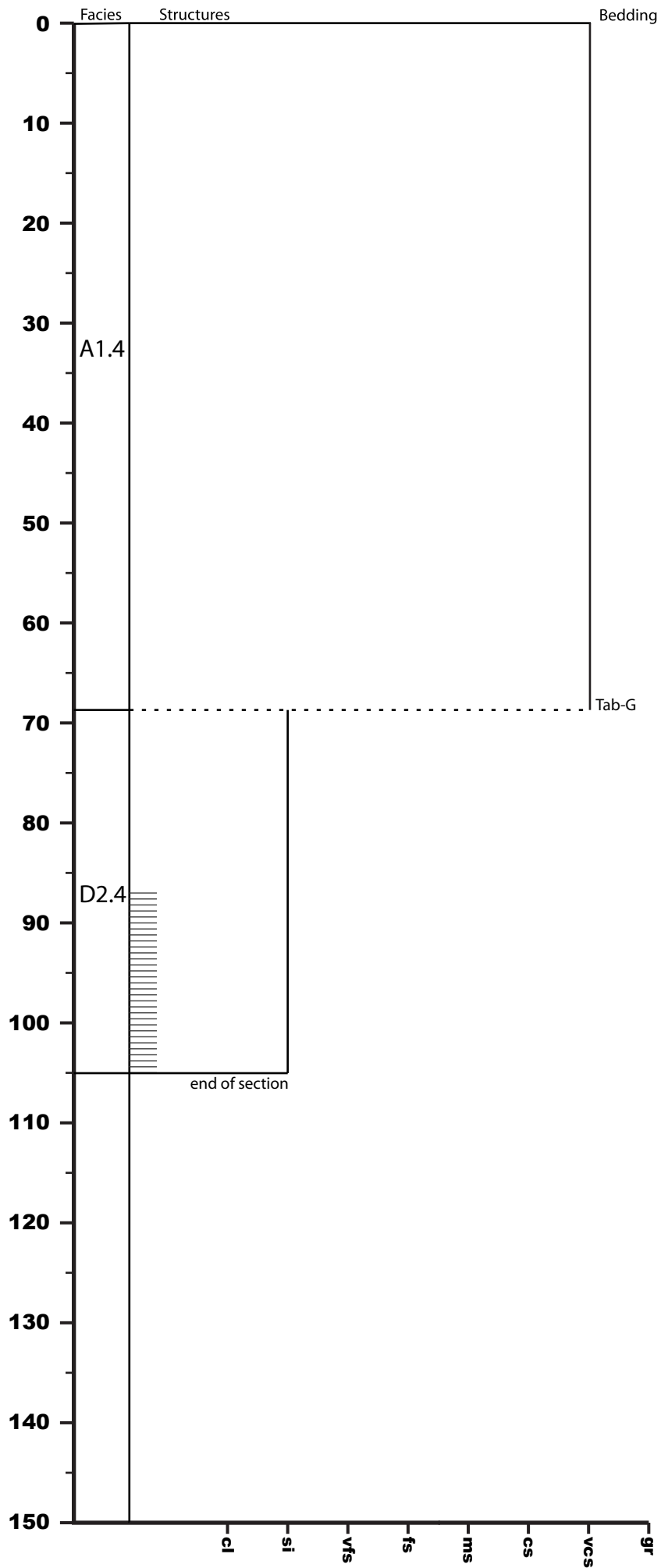

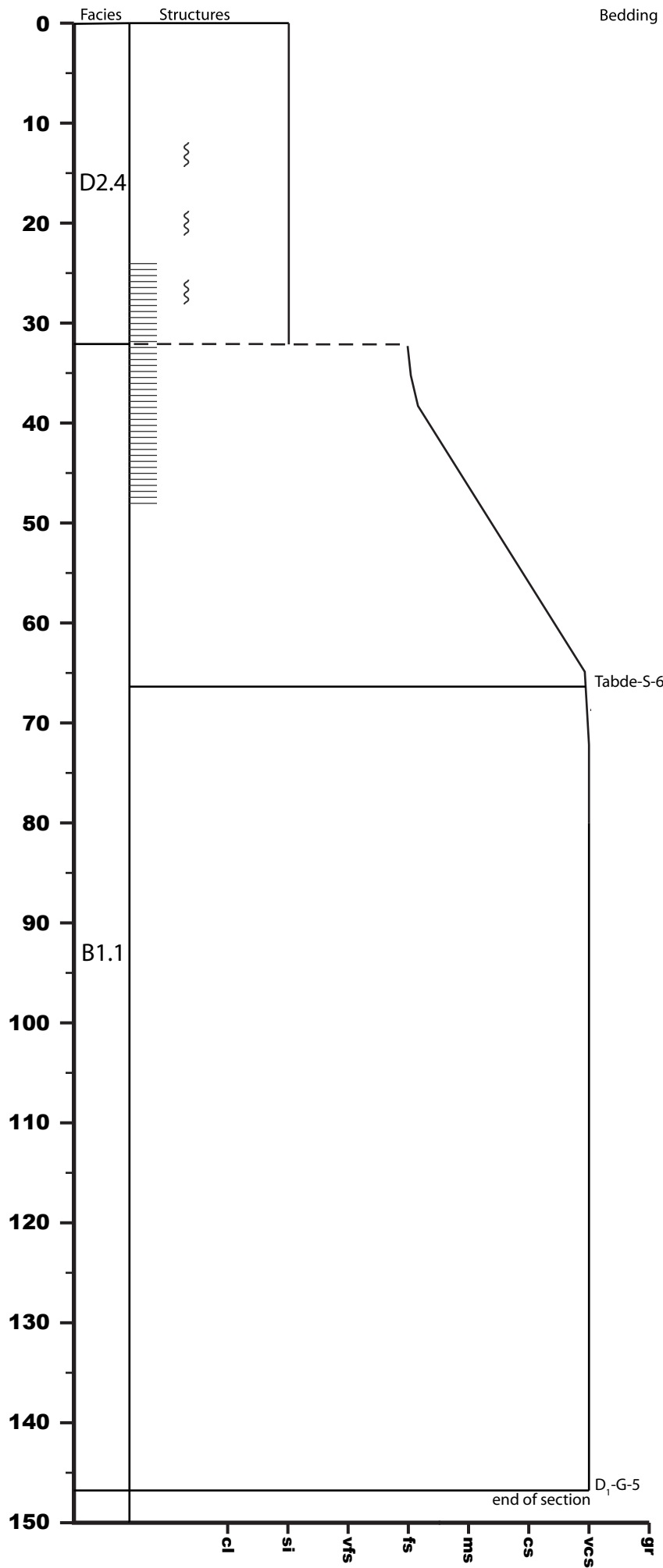

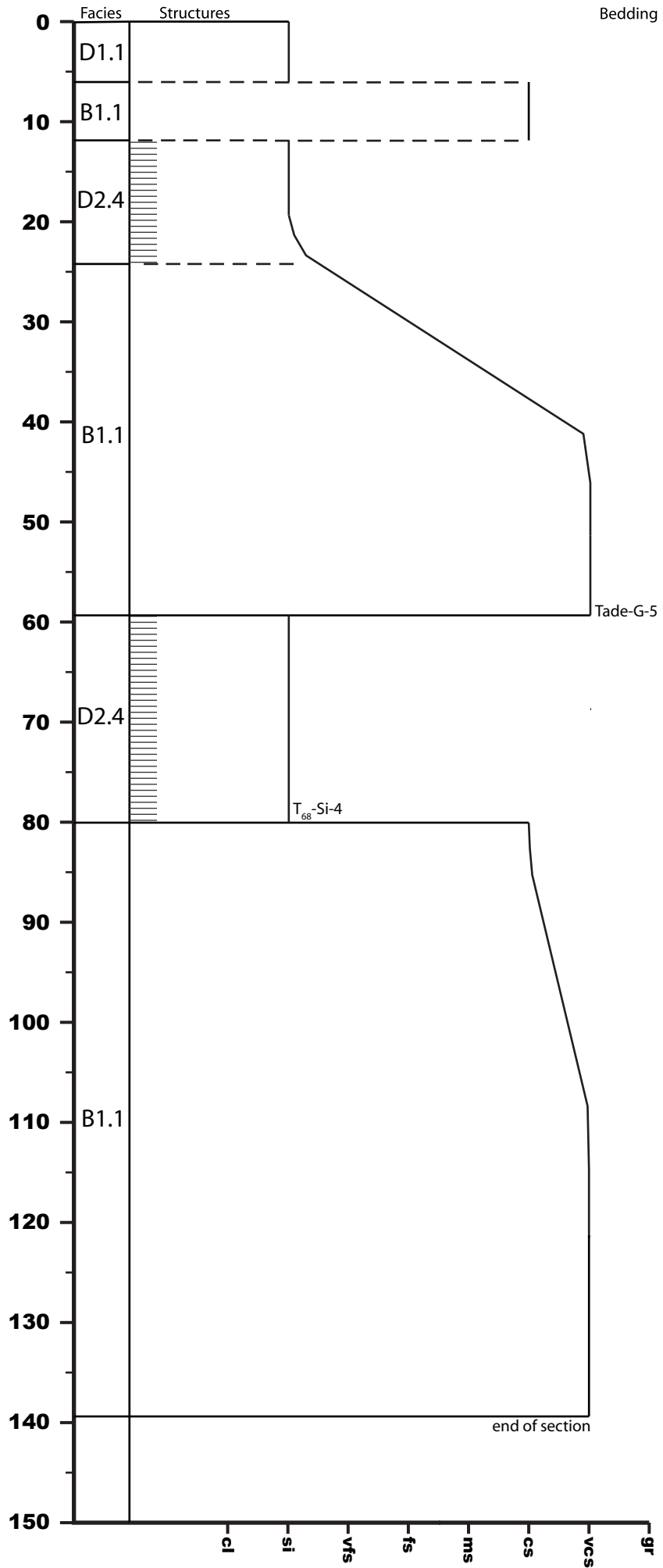

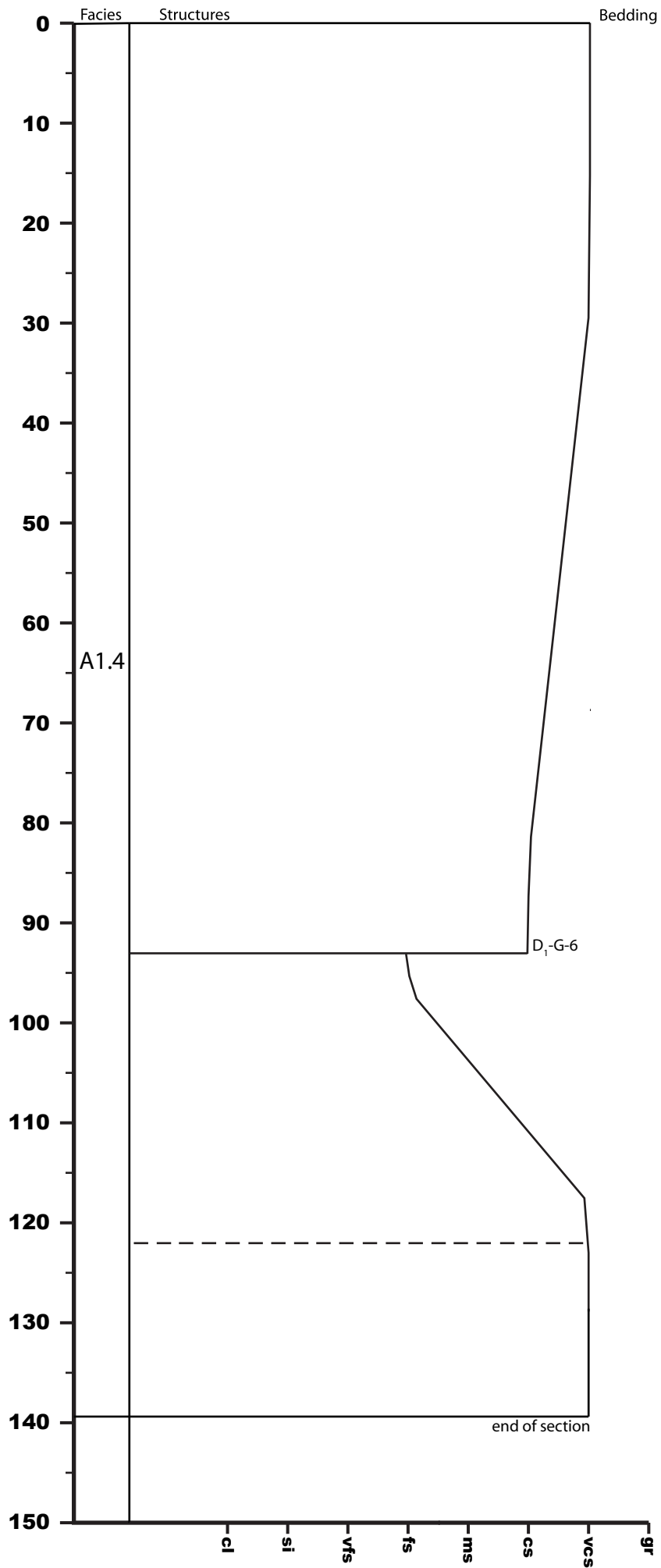



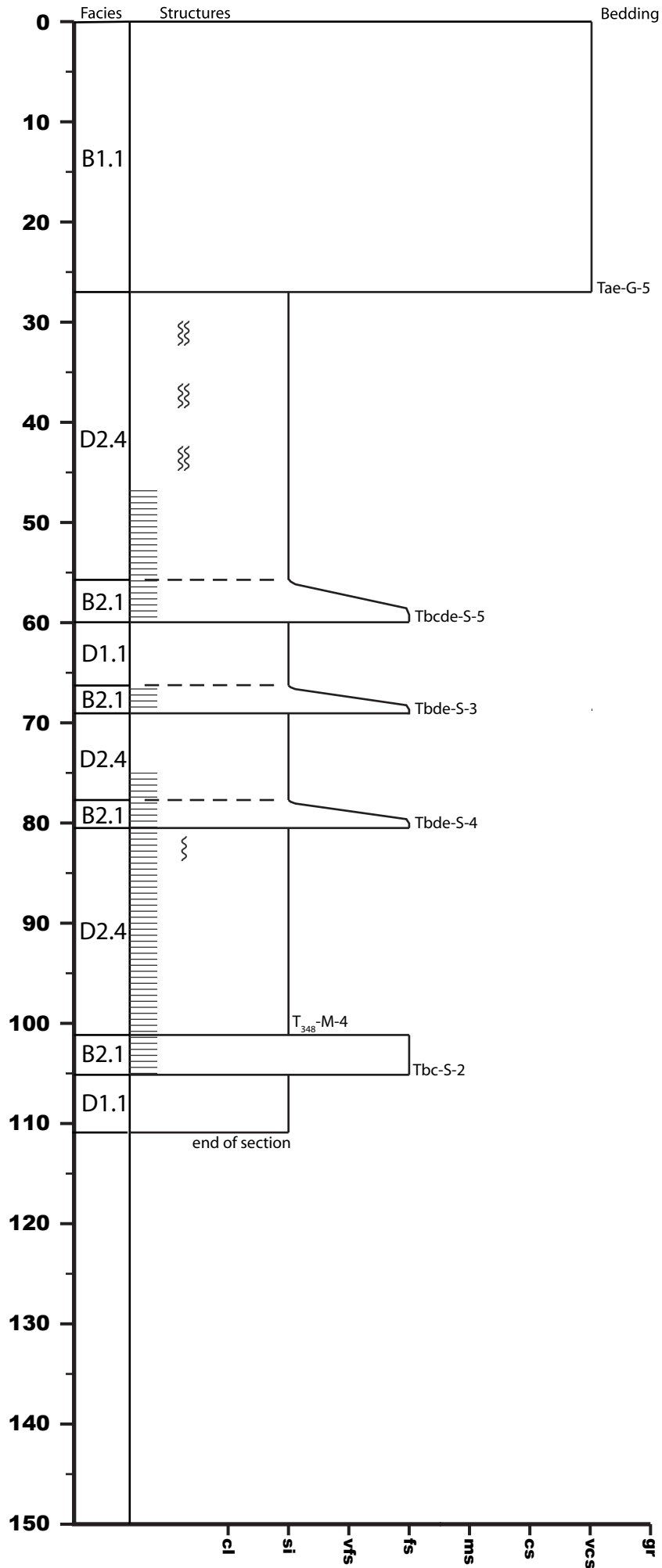

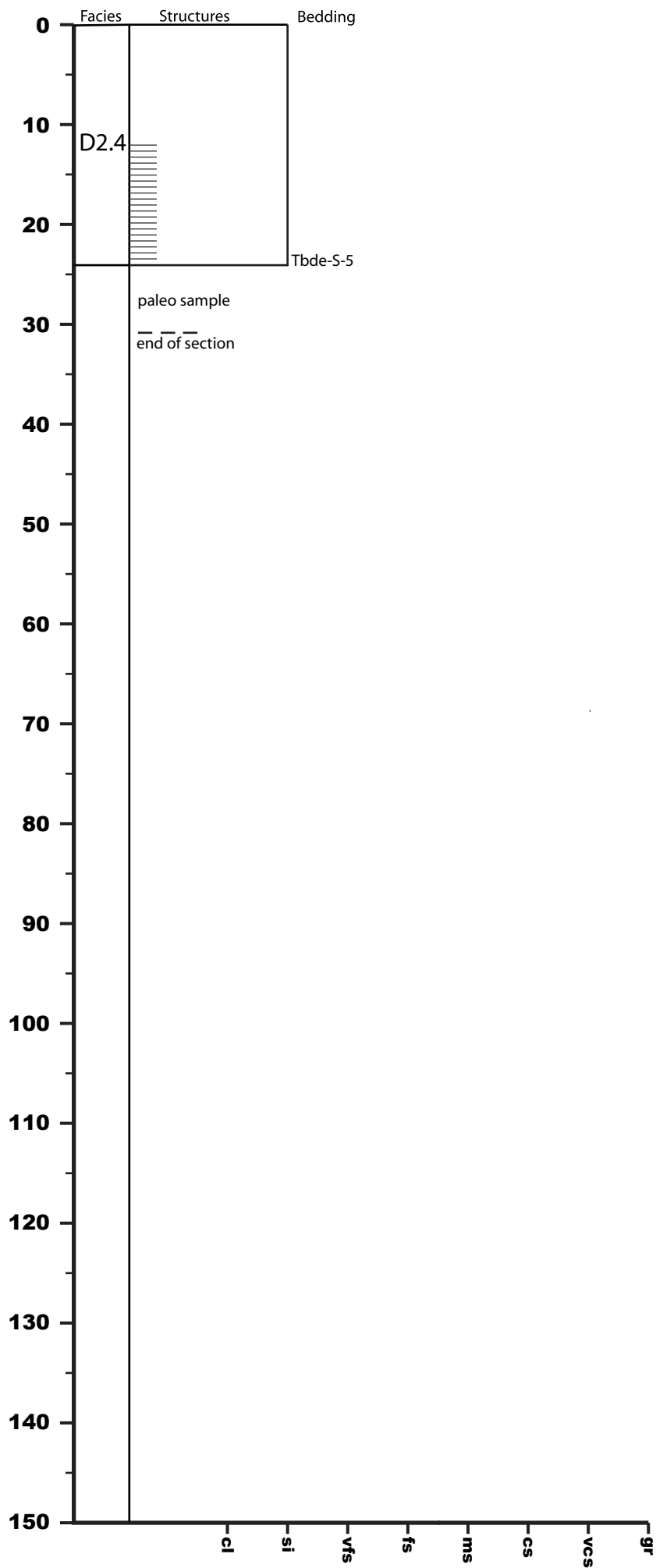

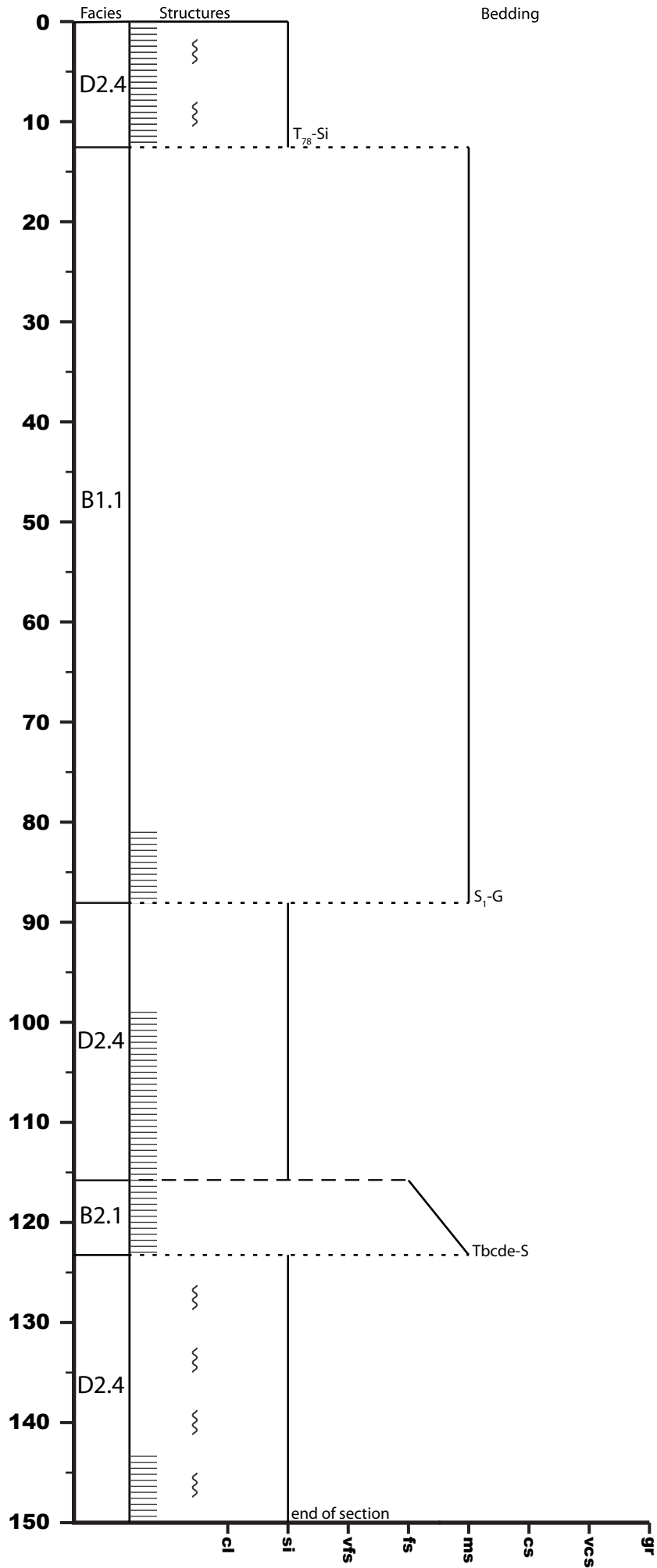

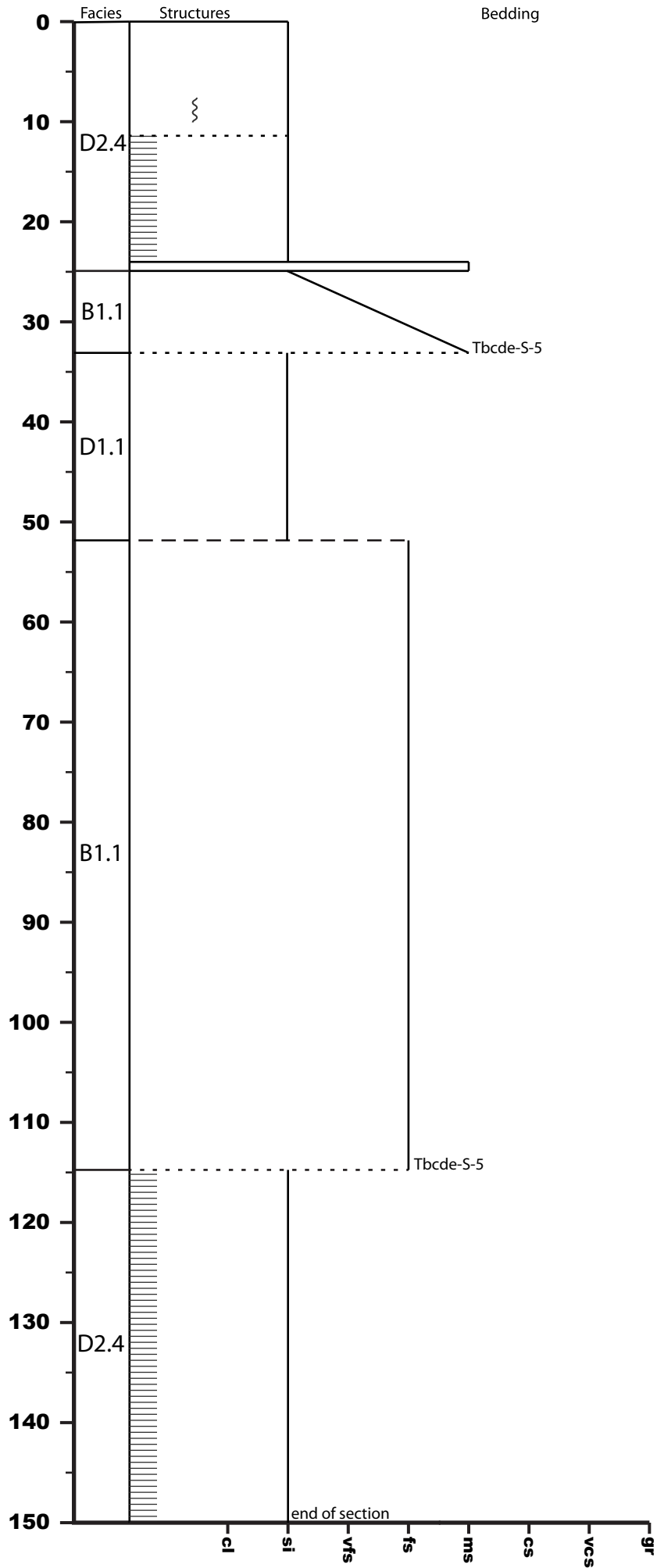

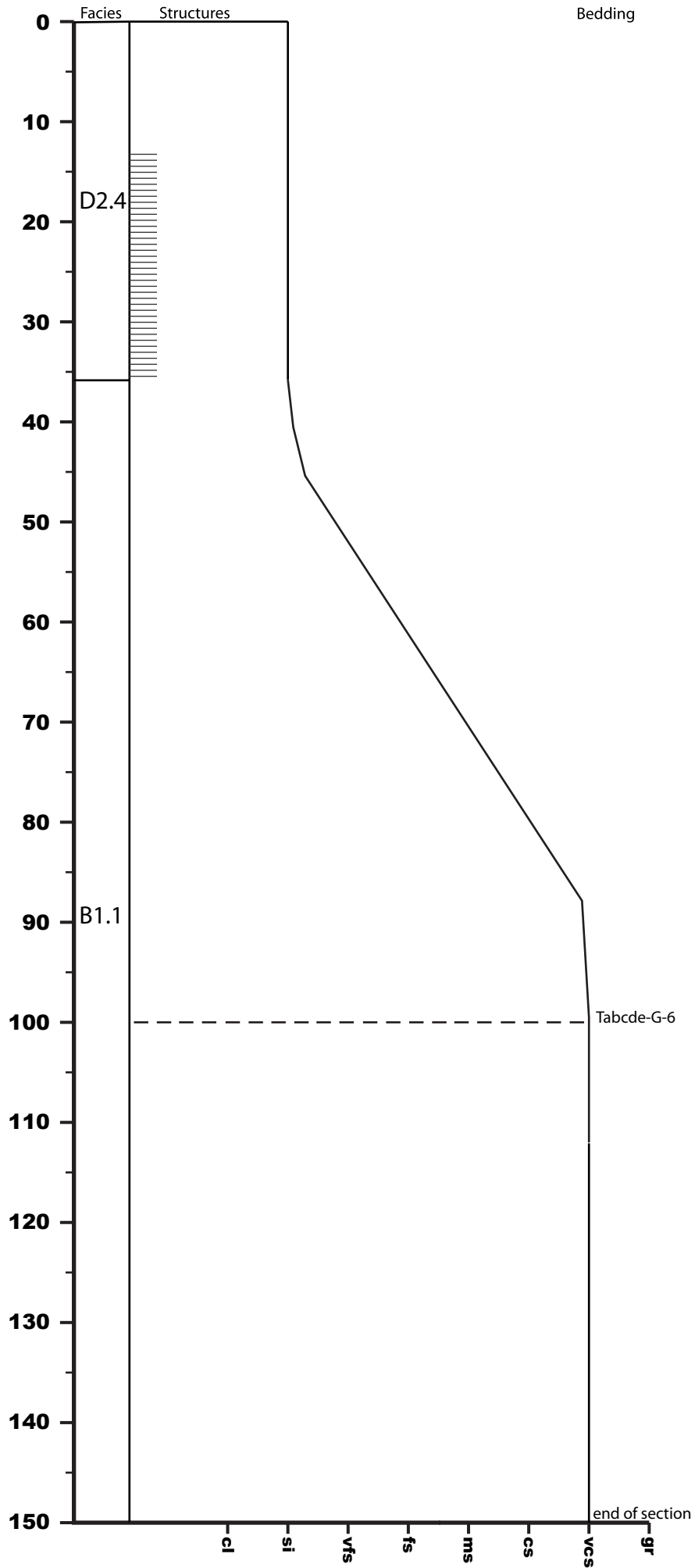

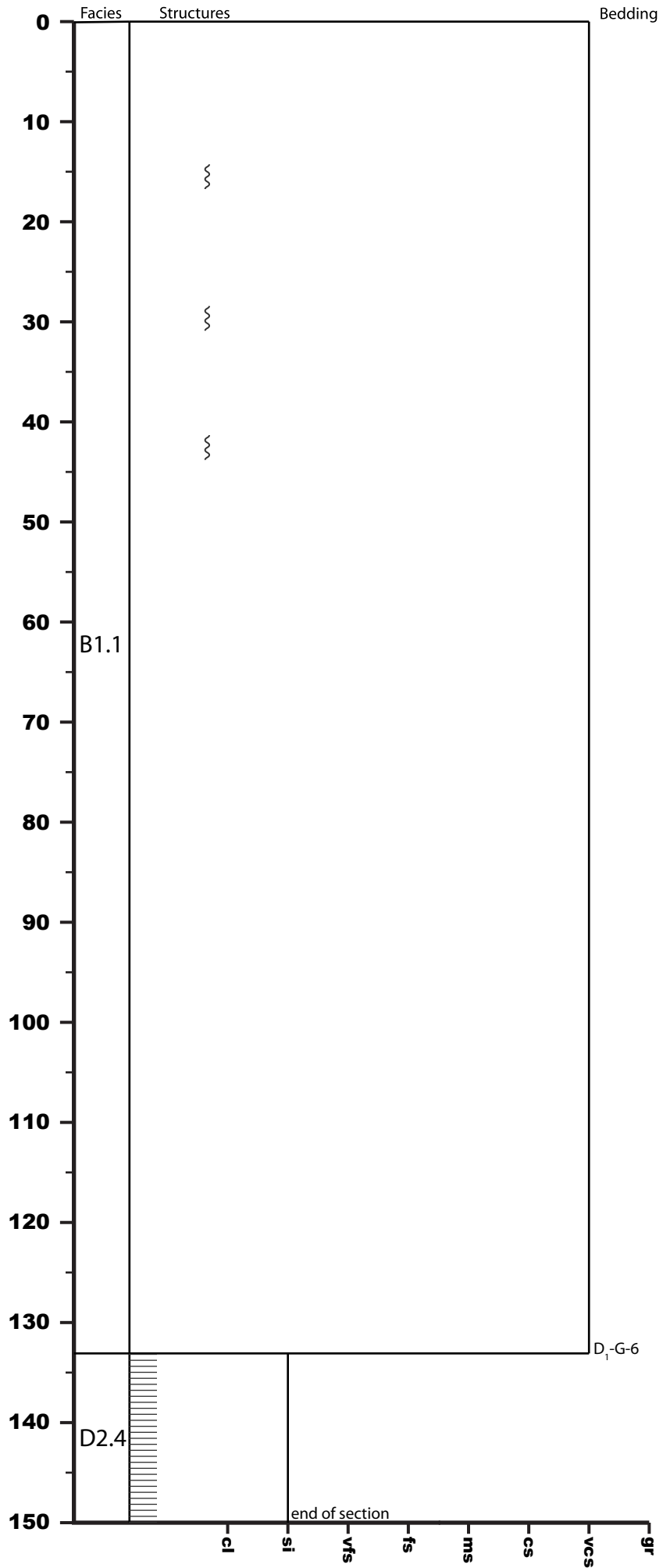

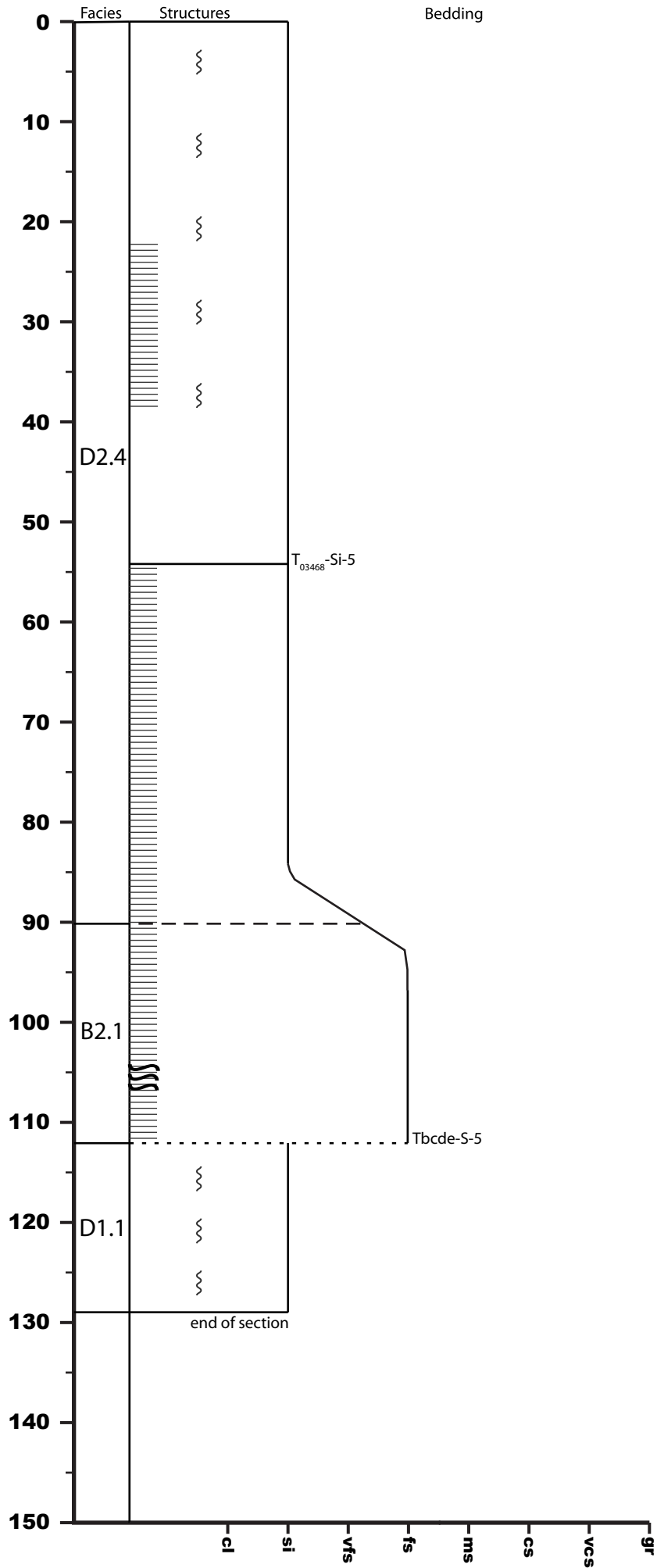

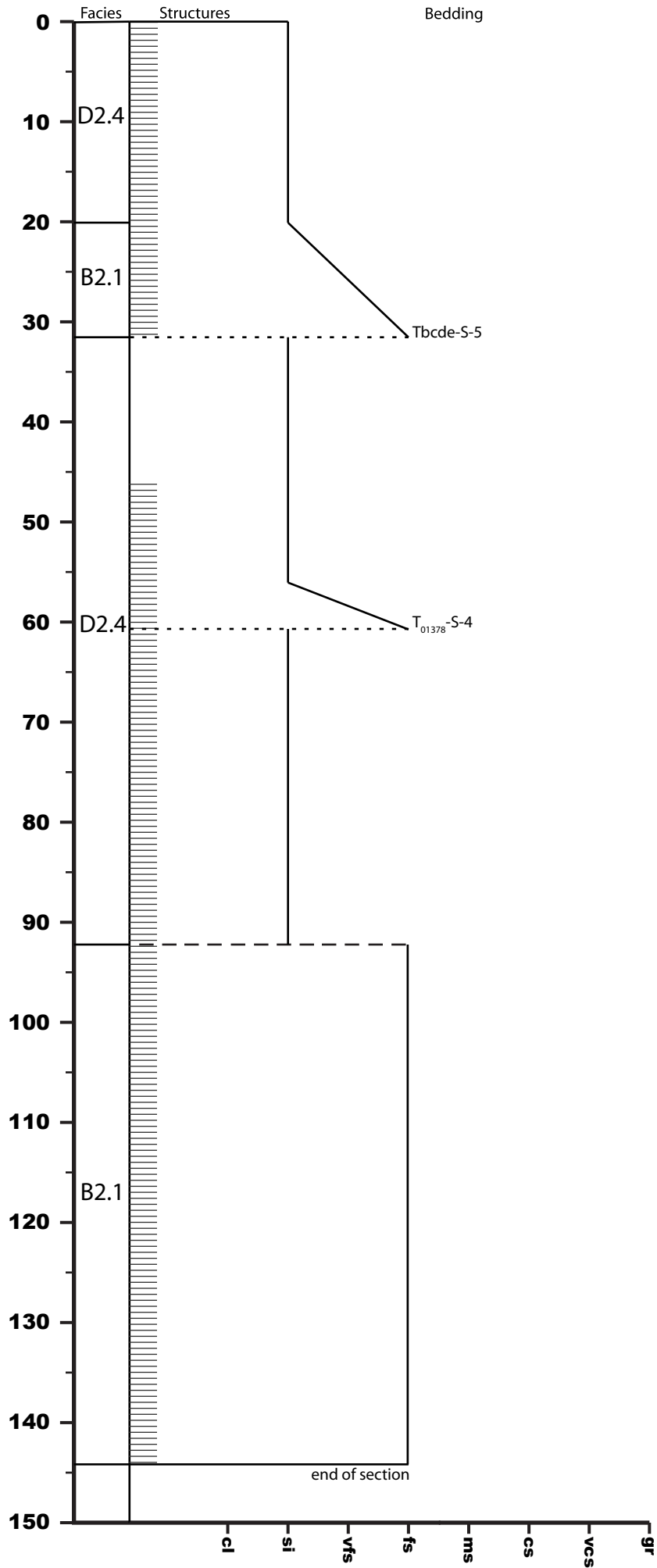



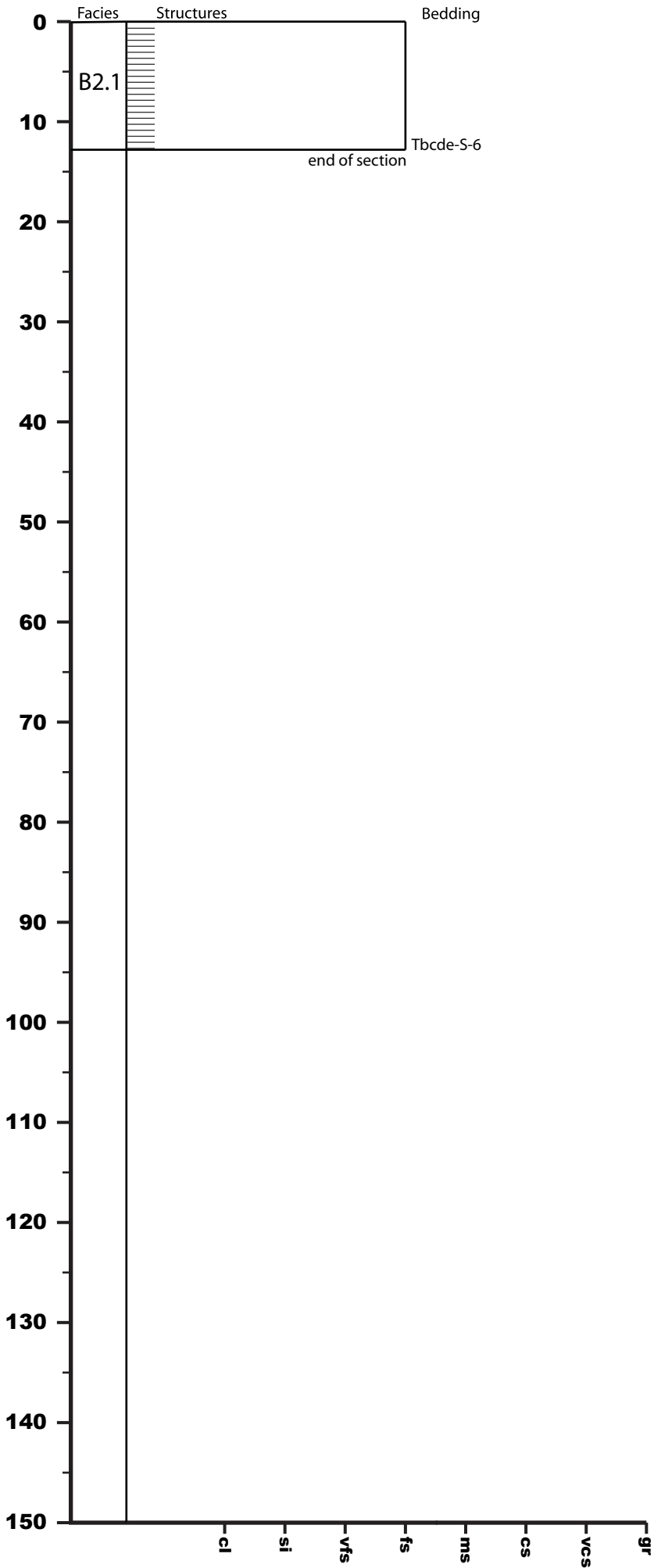

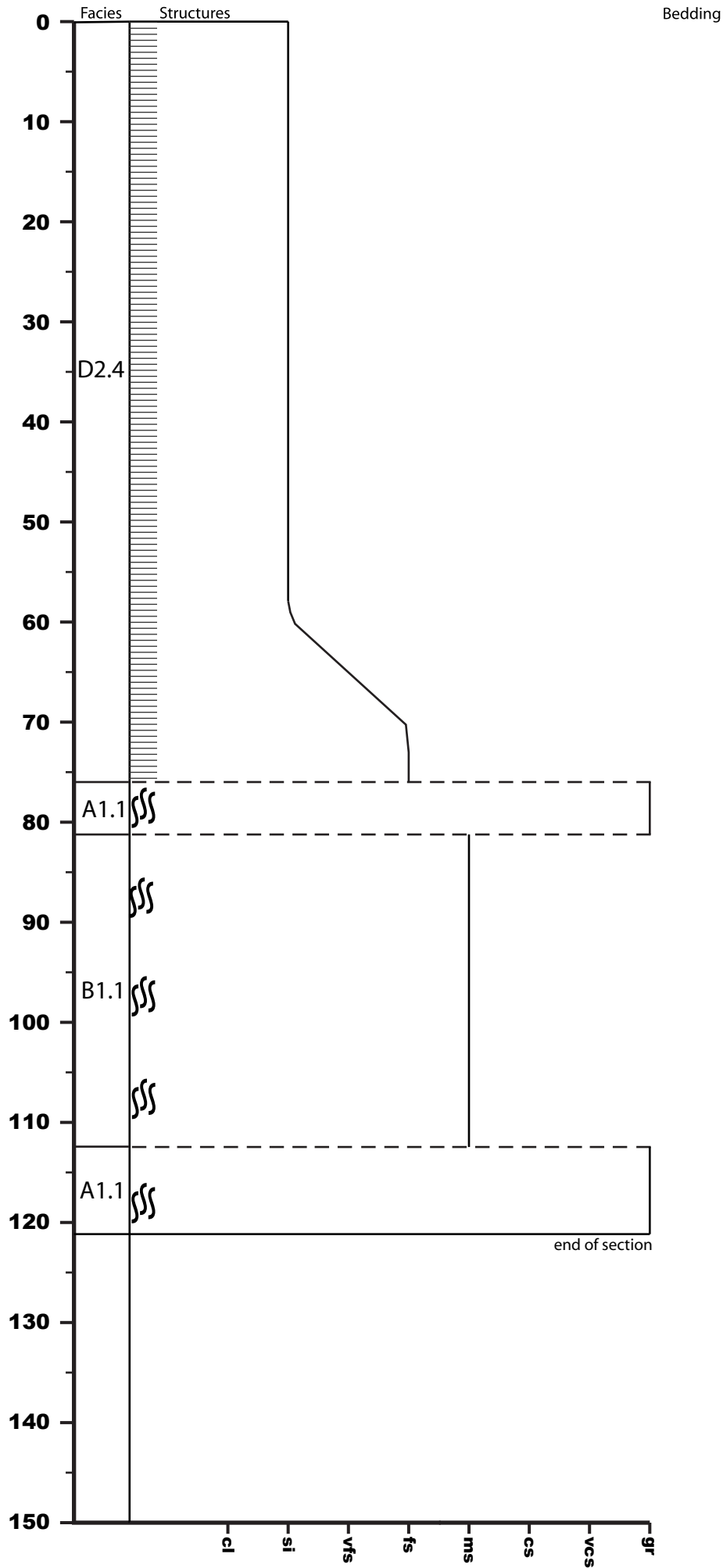

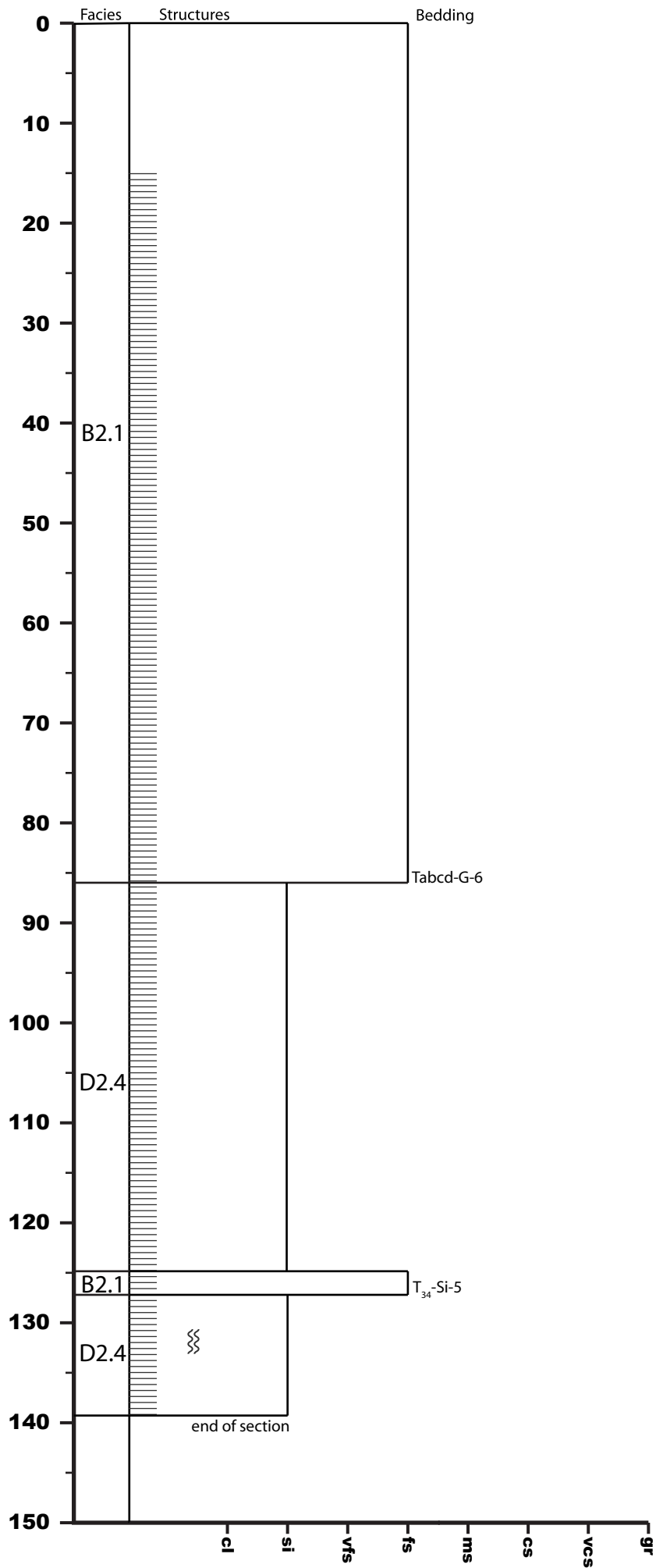

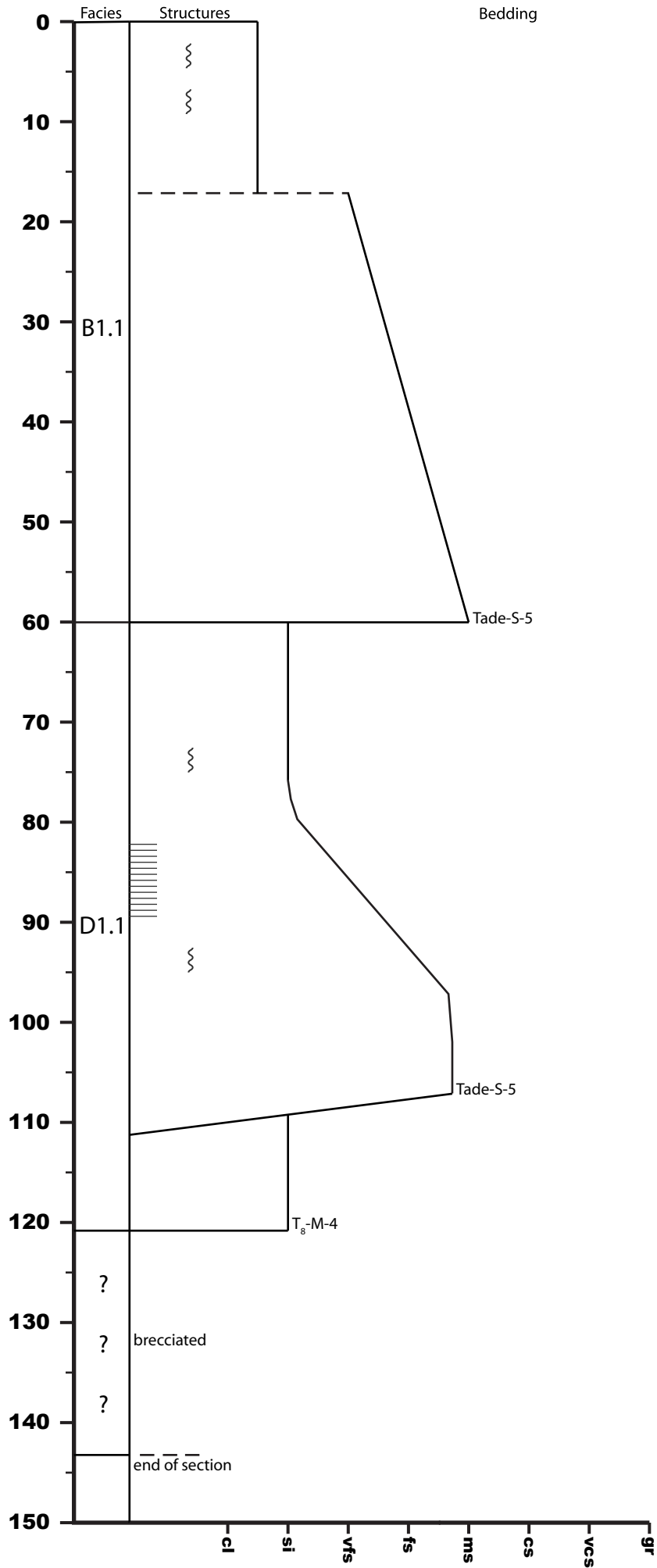

U1438E-39R-CC

1210.69 - 1210.82 mbsf

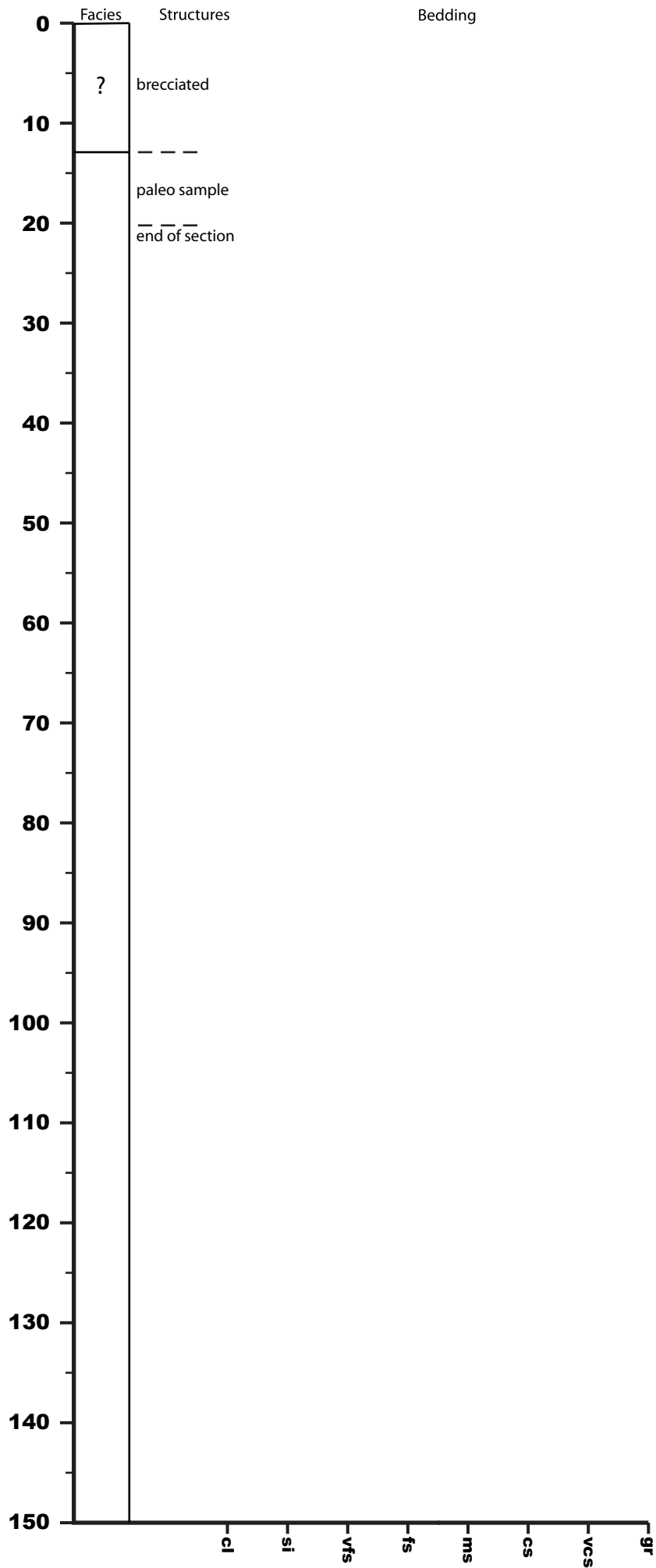

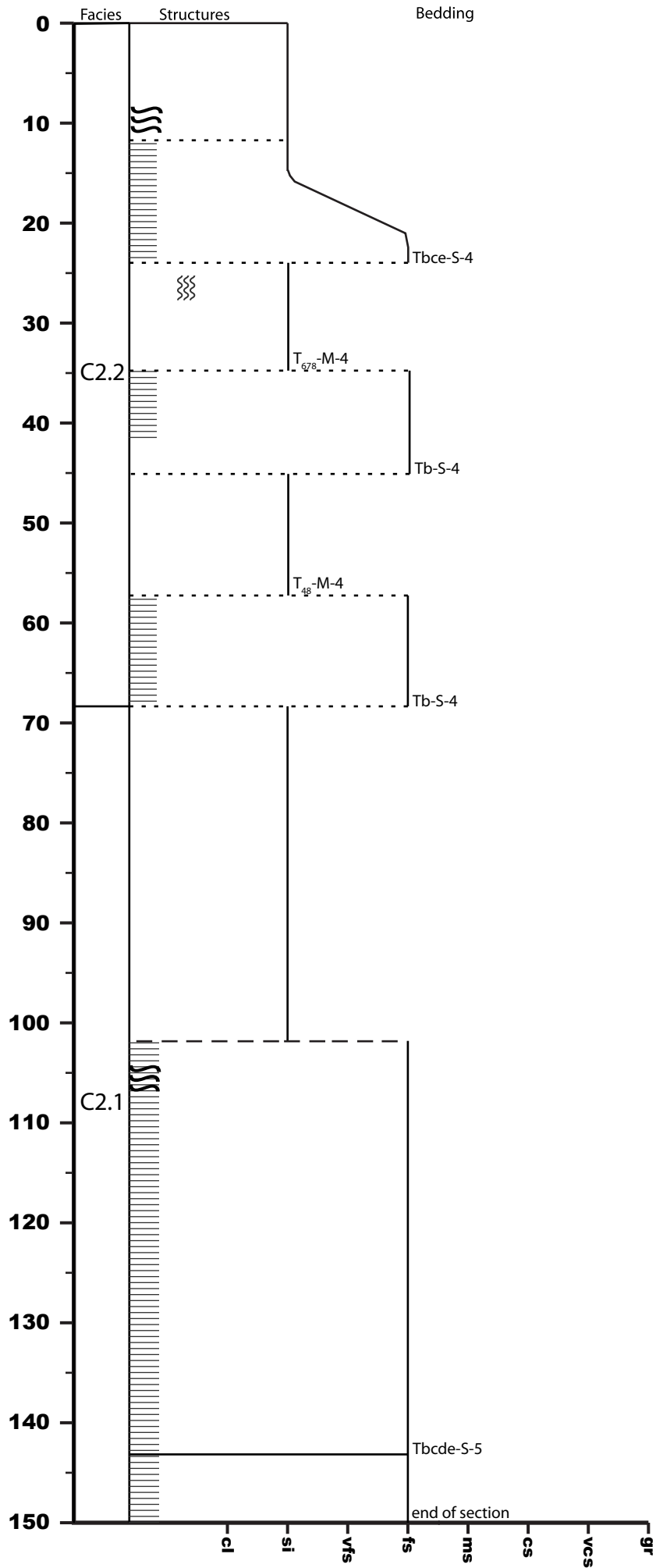

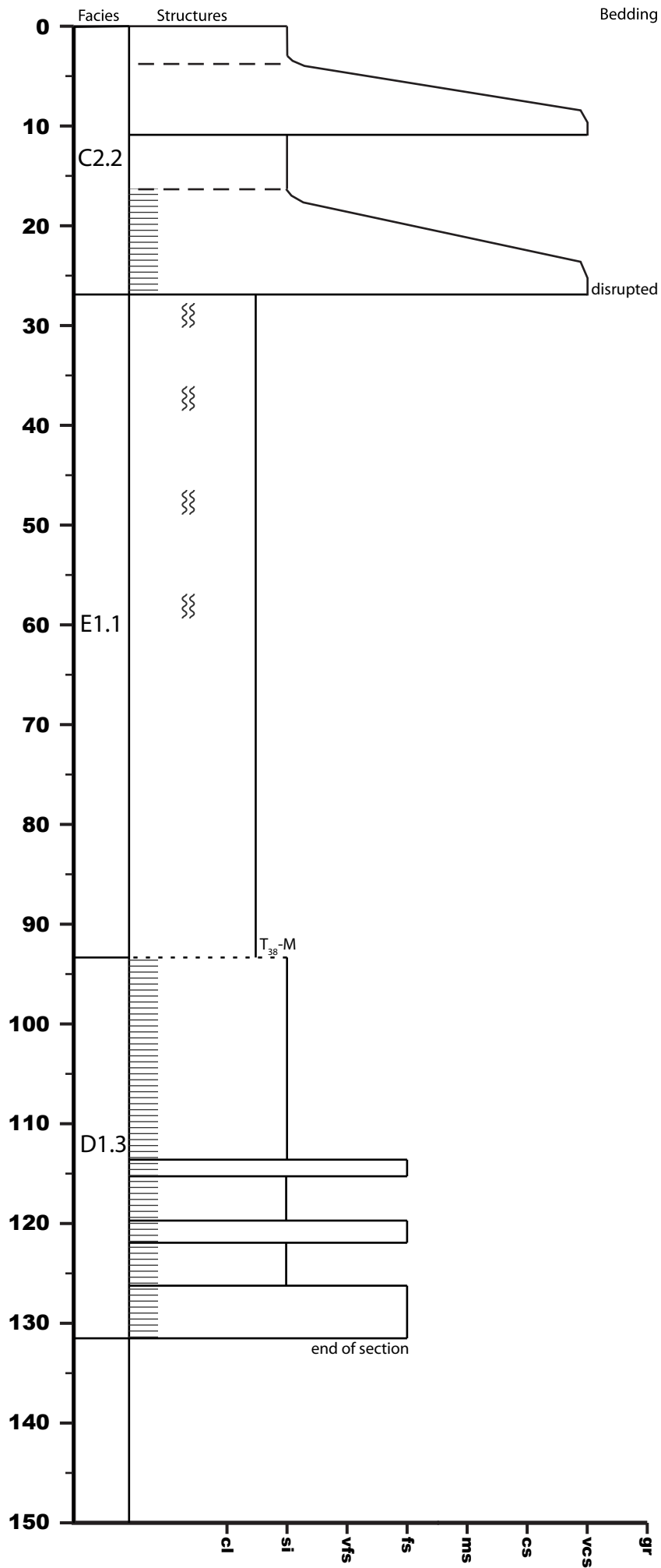

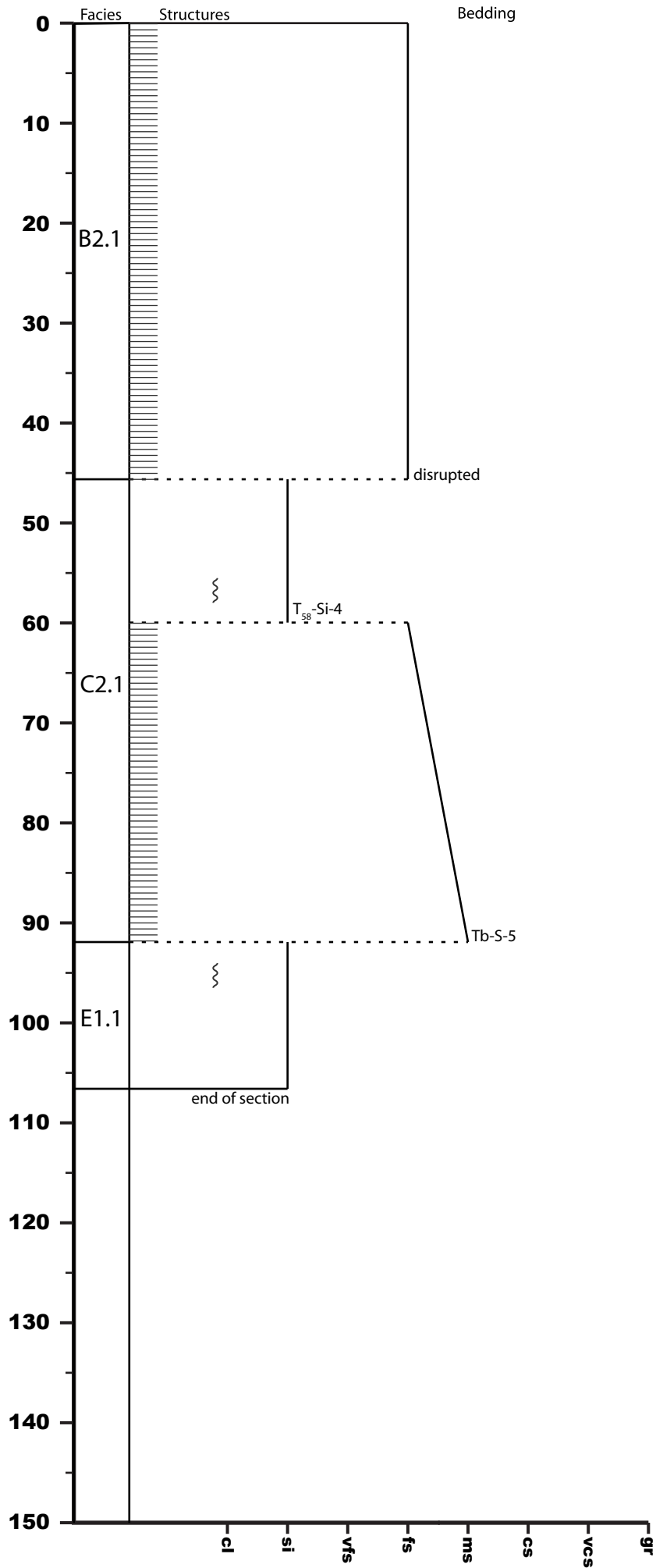



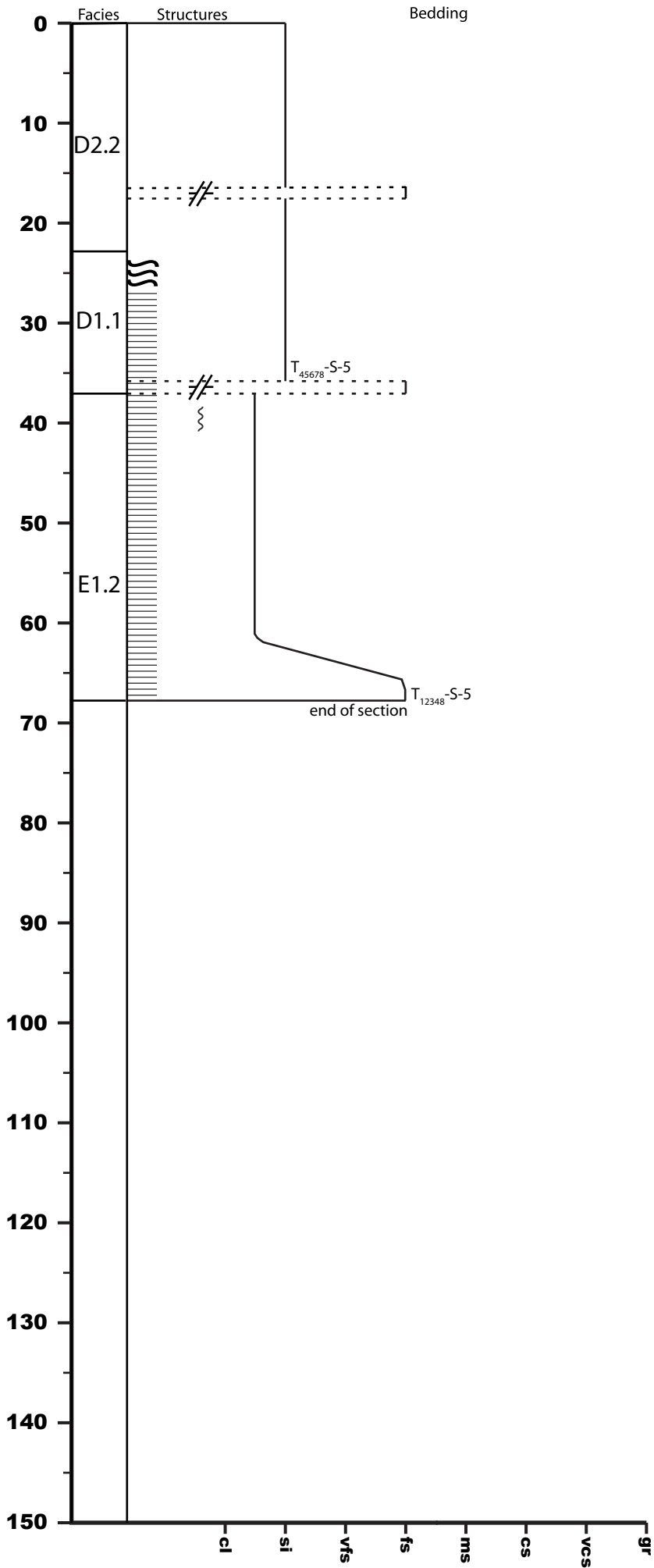

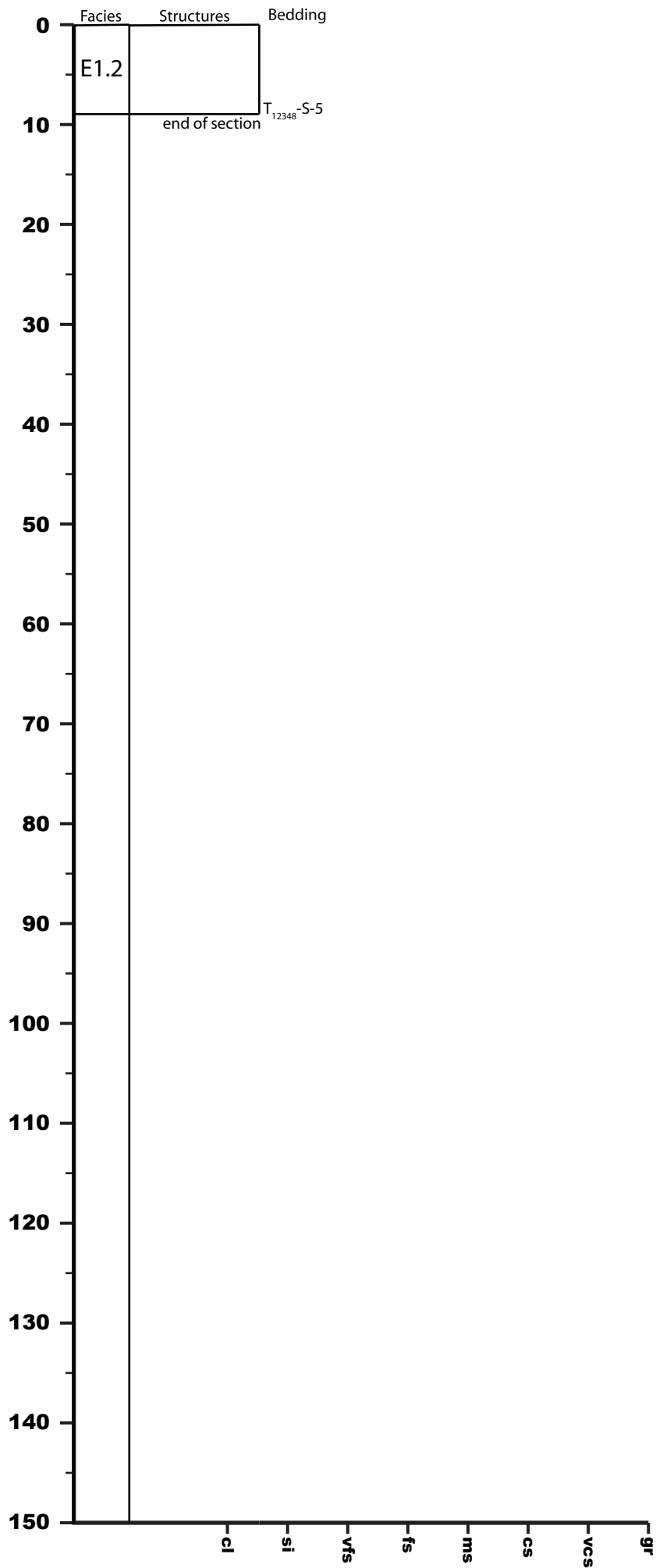

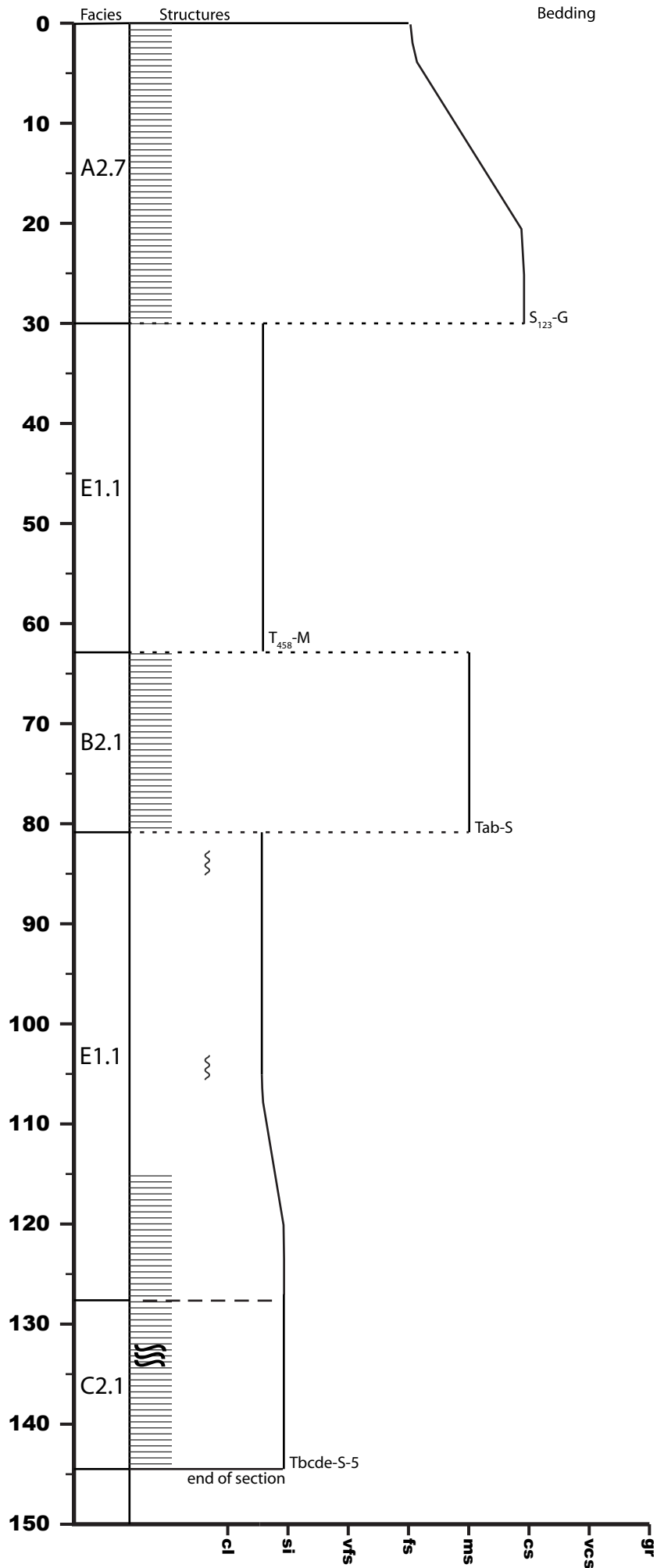

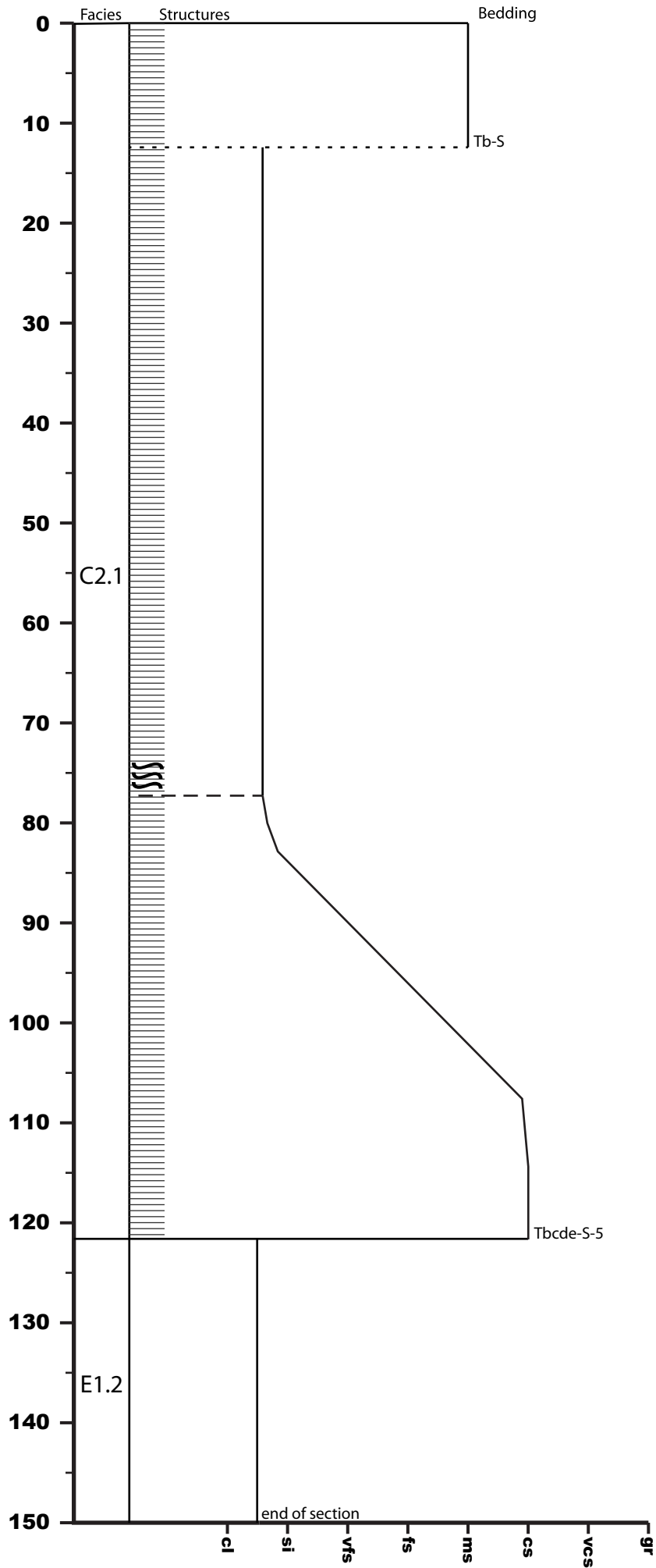

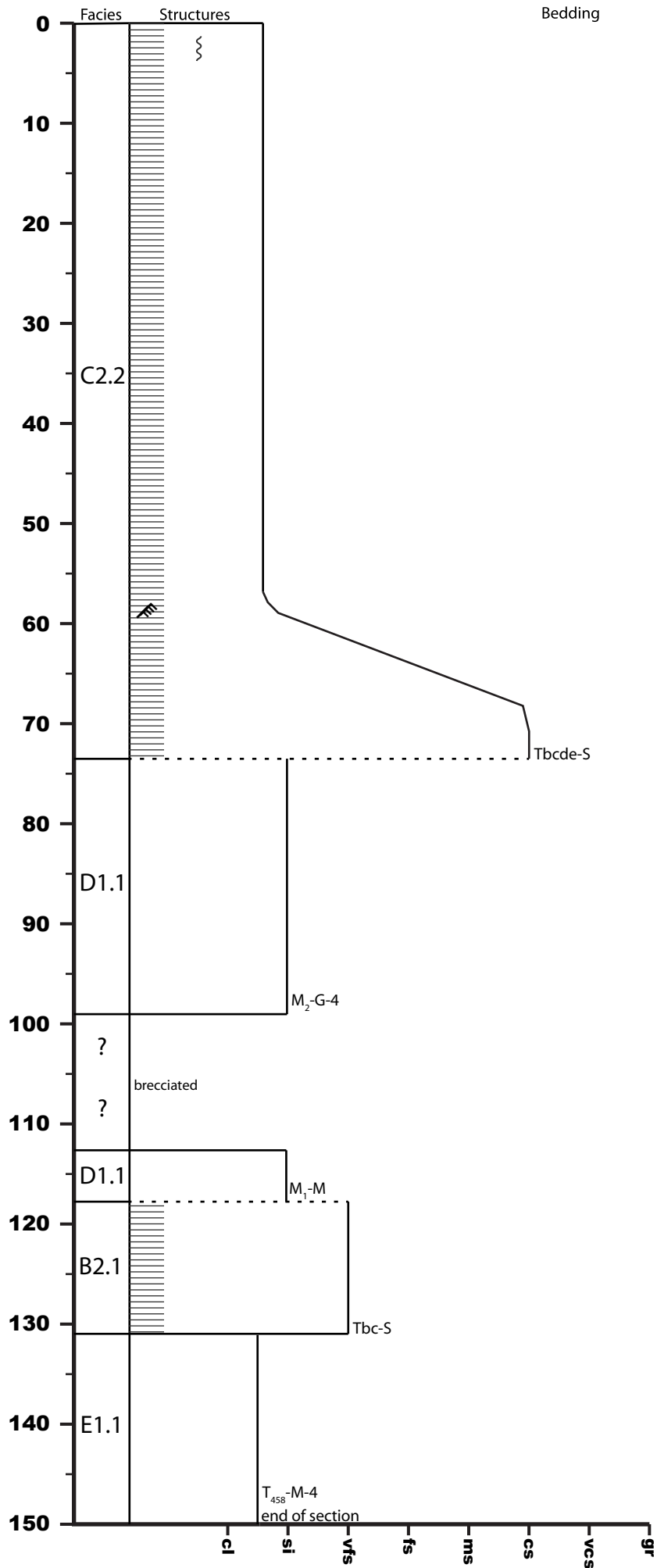

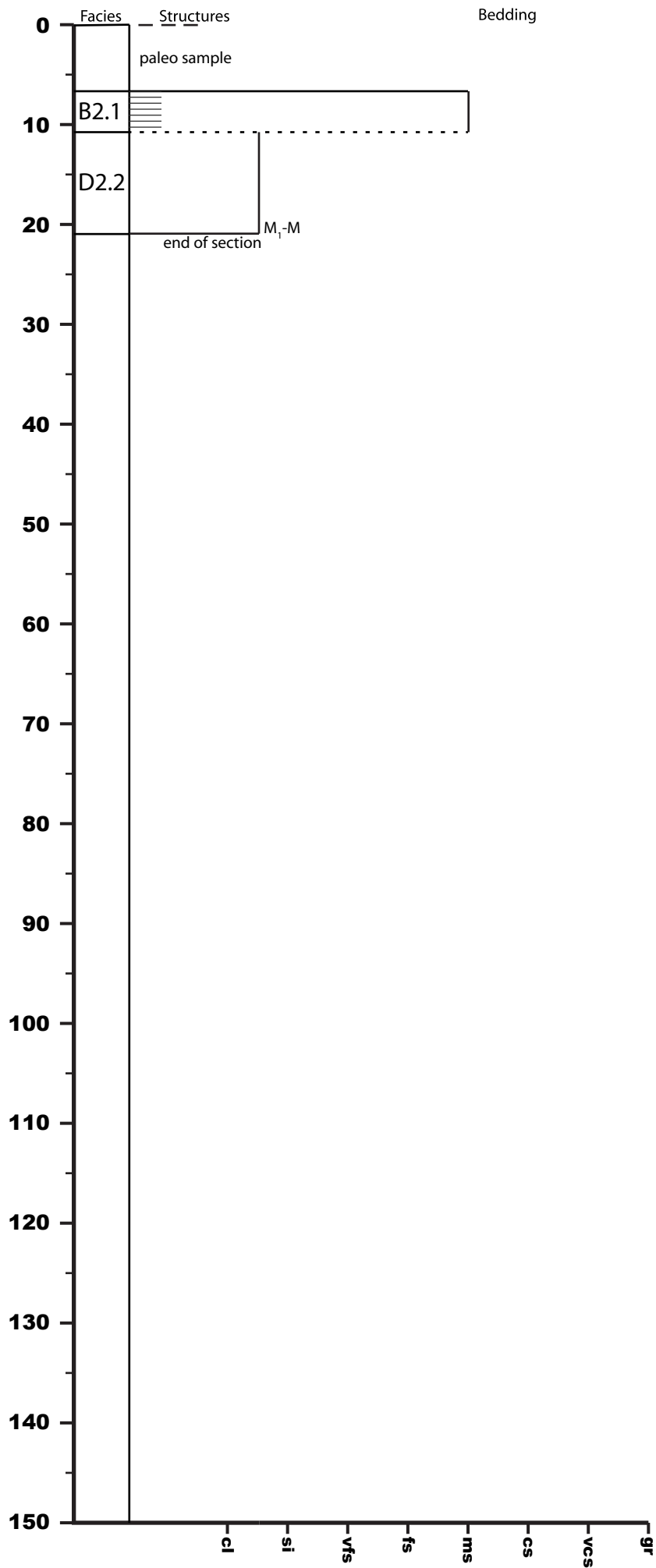

U1438E-42R-1

1235.7 - 1237.16 mbsf

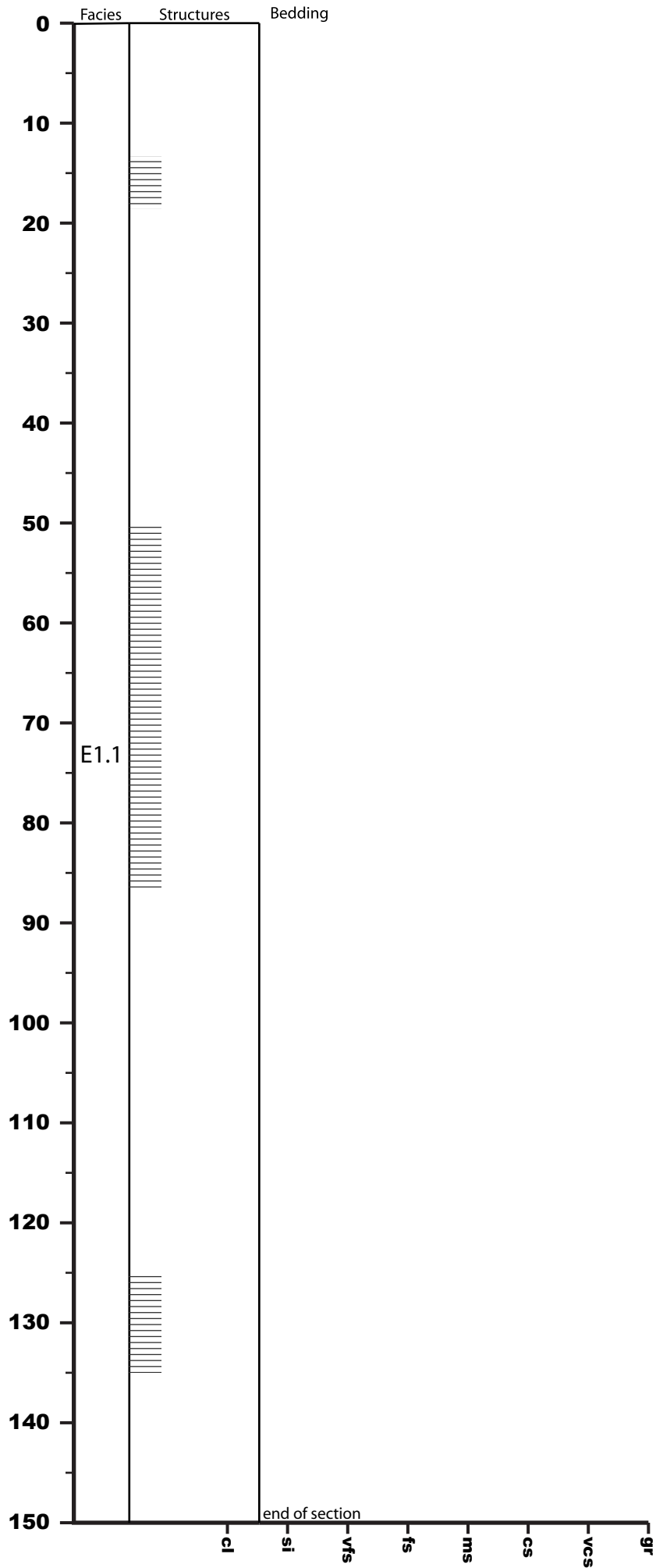

U1438E-42R-2

1237.2 - 1238.21 mbsf

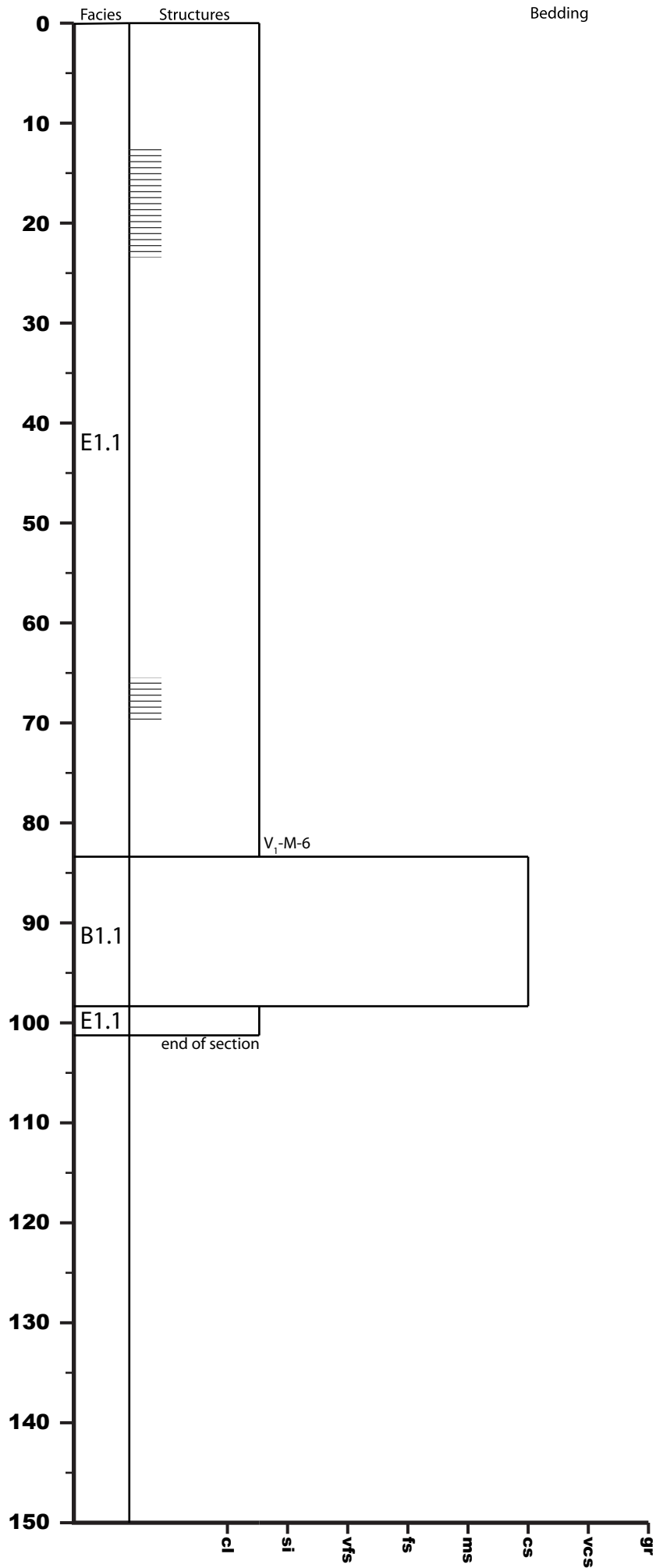



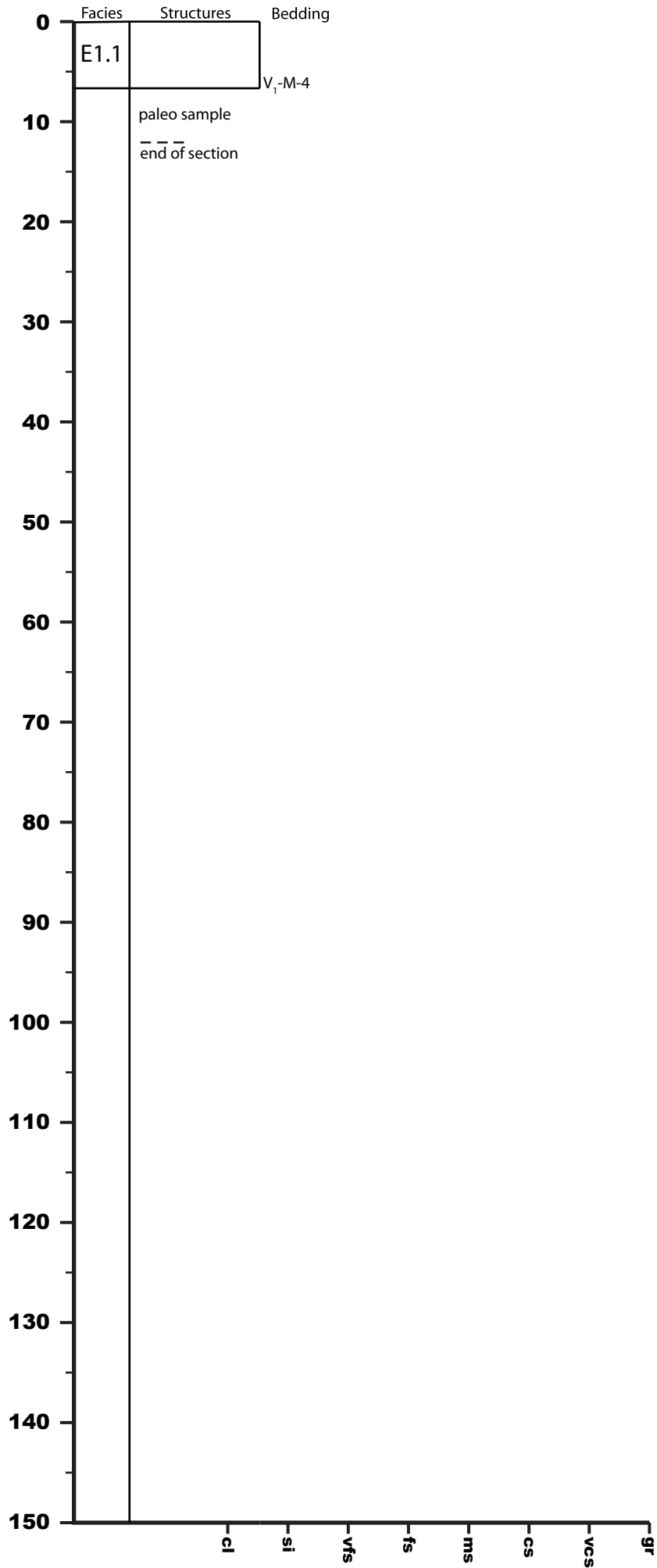

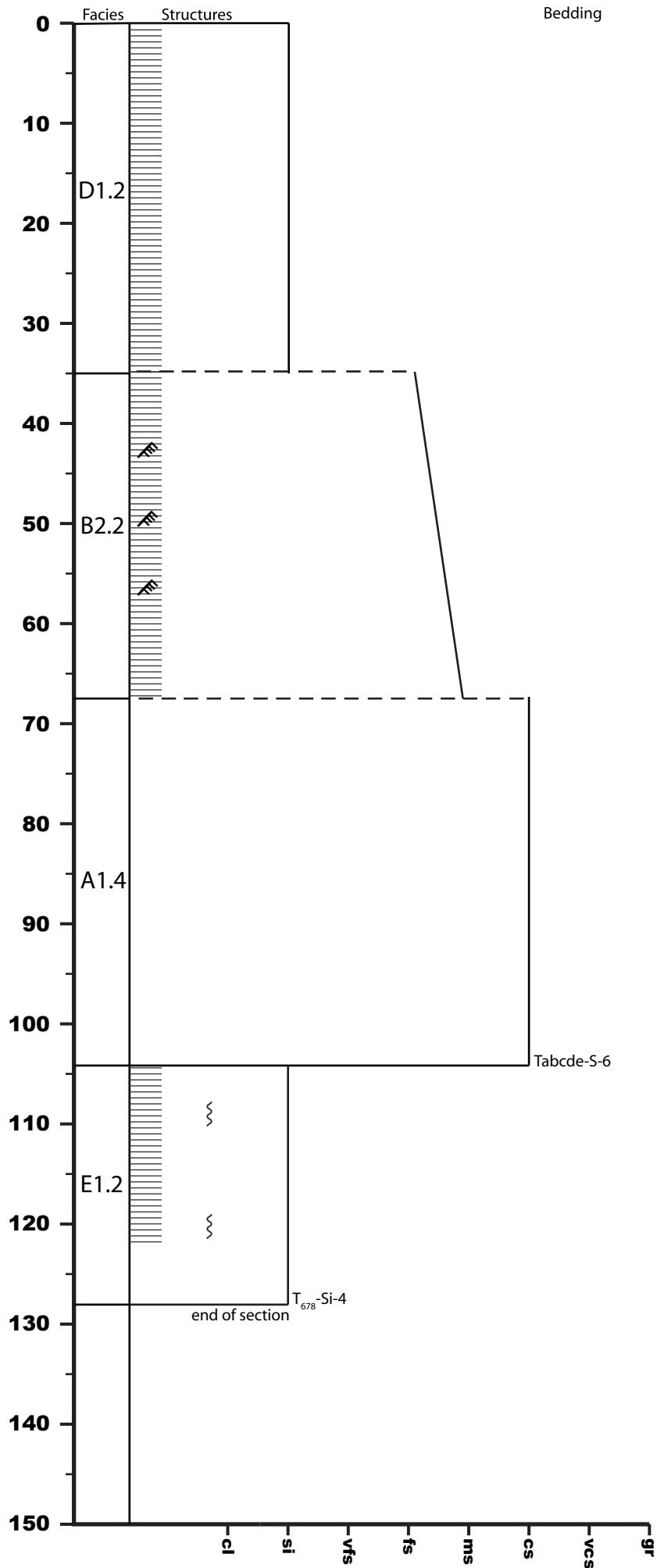

U1438E-43R-2

1246.68 - 1248.19 mbsf

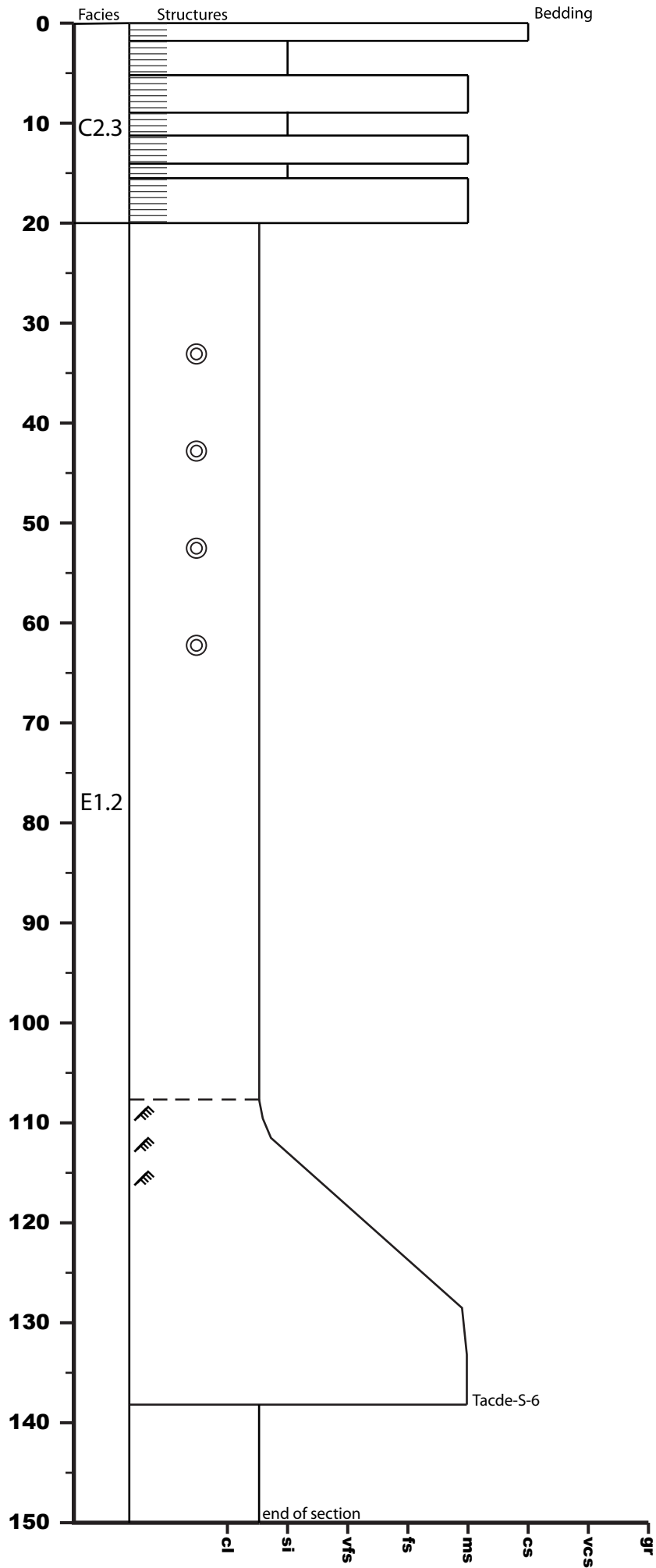

U1438E-43R-3

1248.19 - 1249.67 mbsf

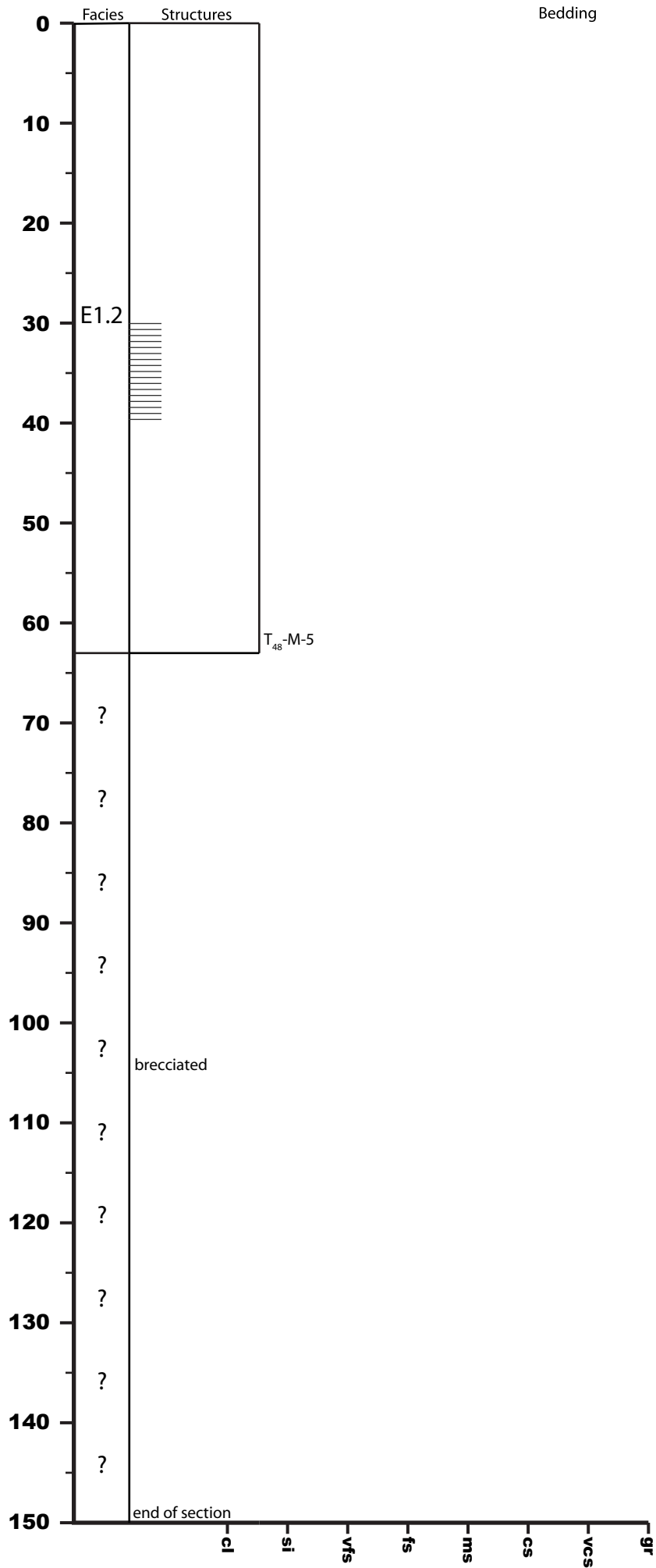

U1438E-43R-4

1249.67 - 1250.28 mbsf

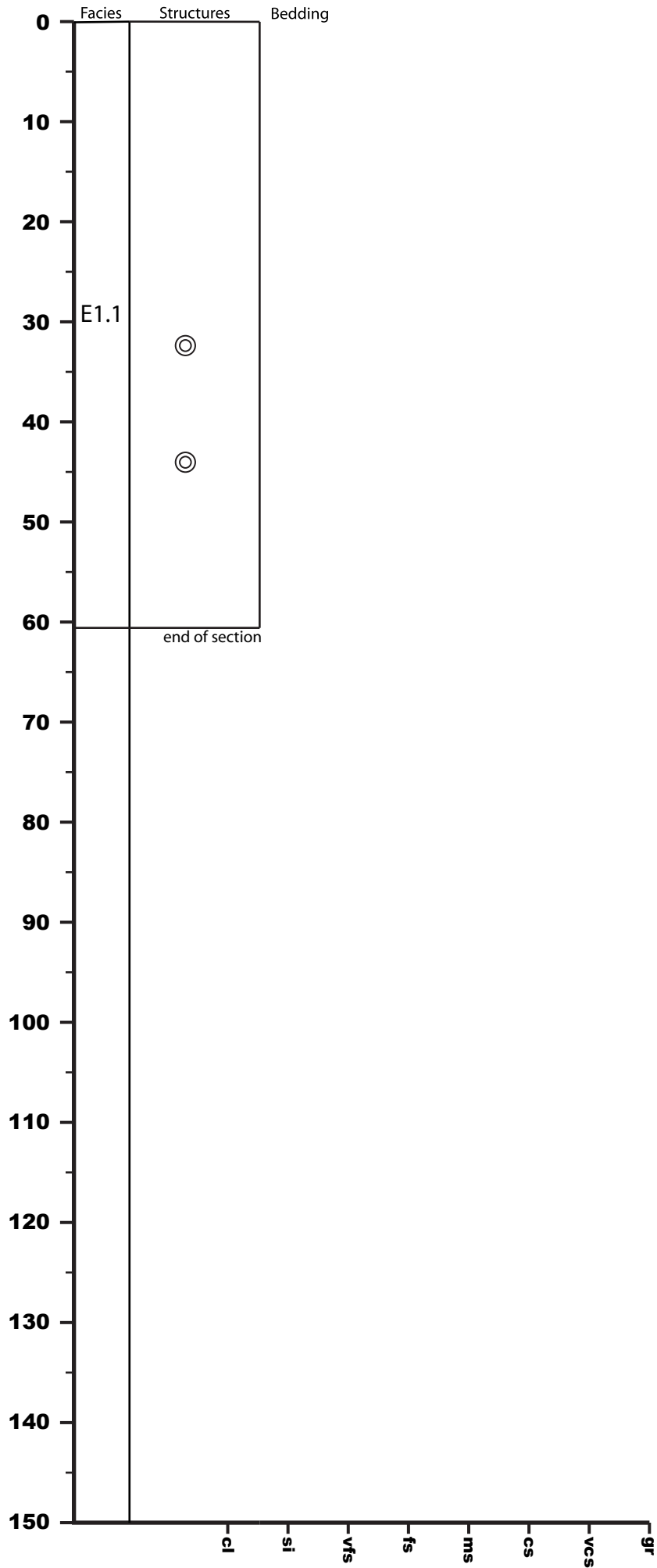

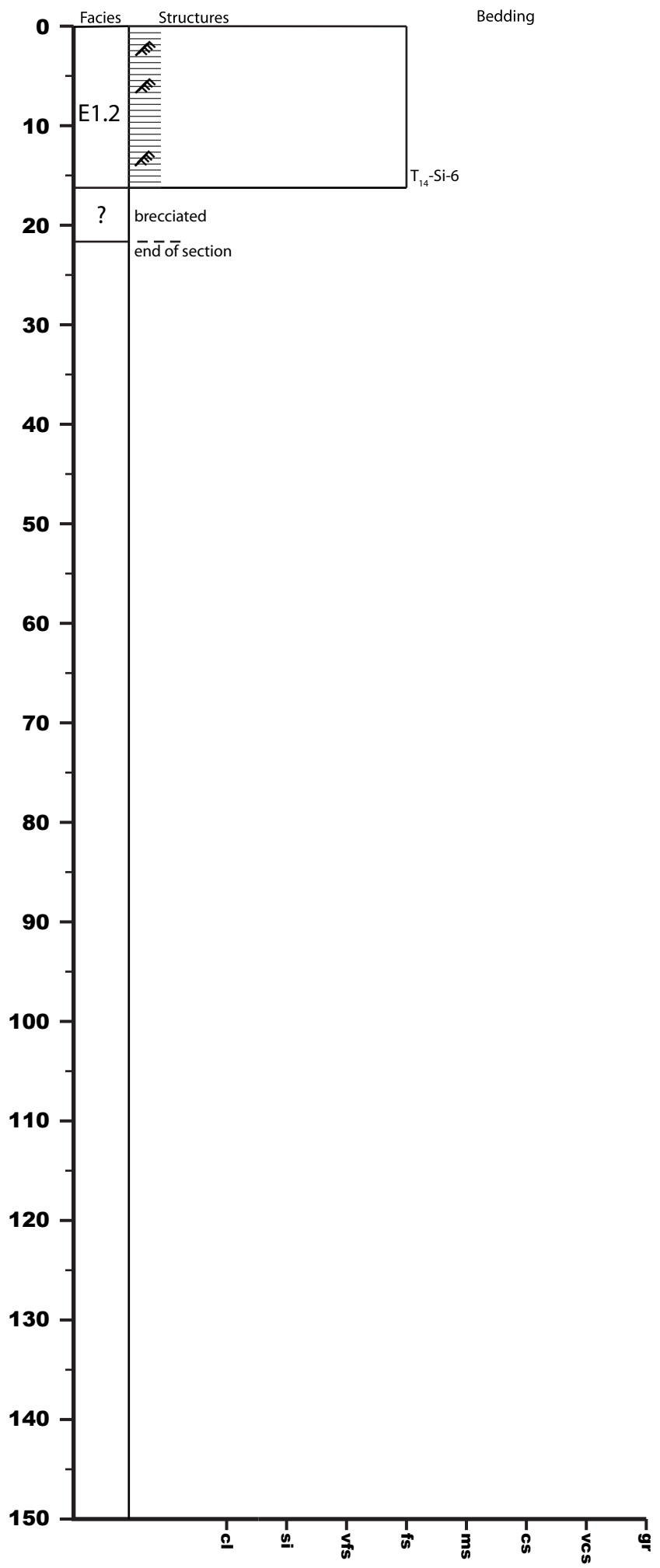

U1438E-44R-1

1255.1 - 1256.28 mbsf

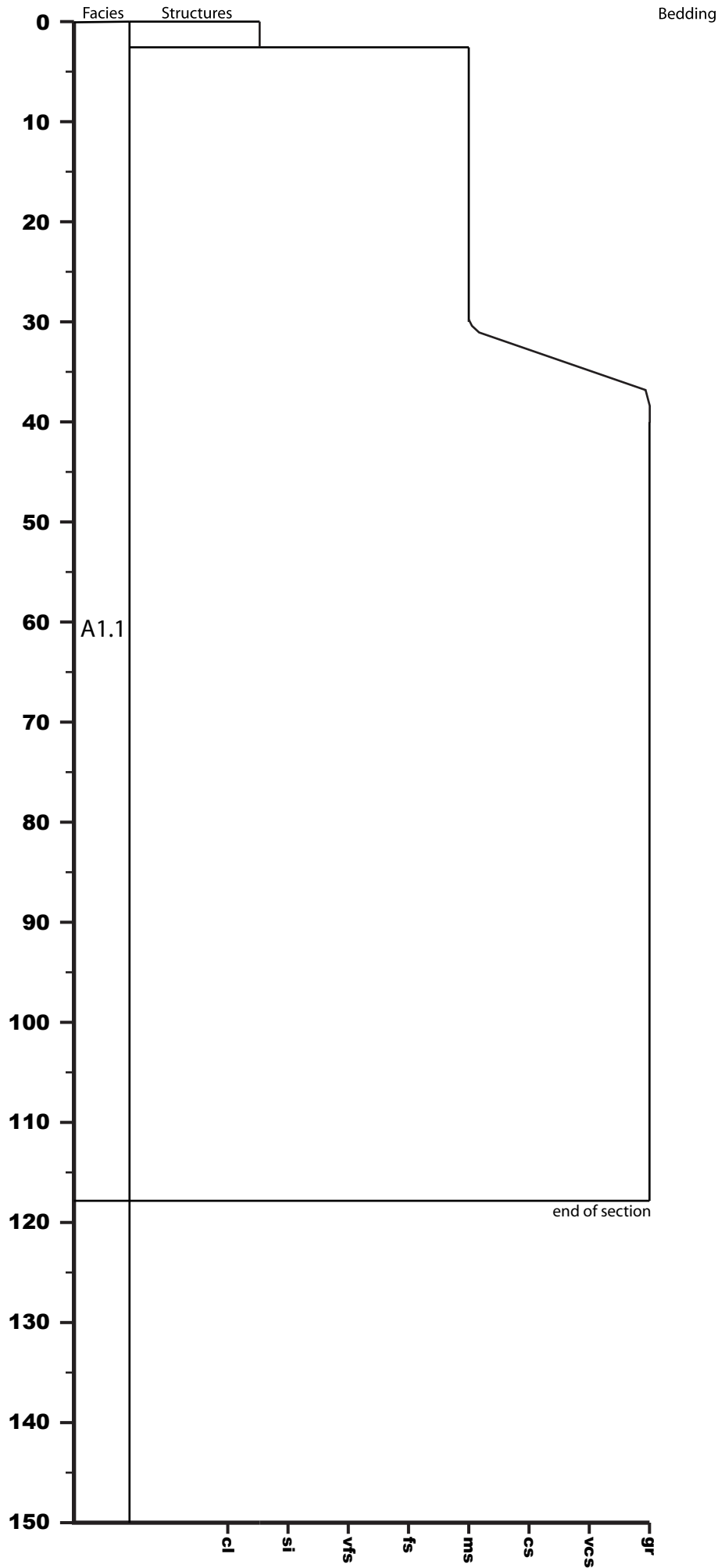

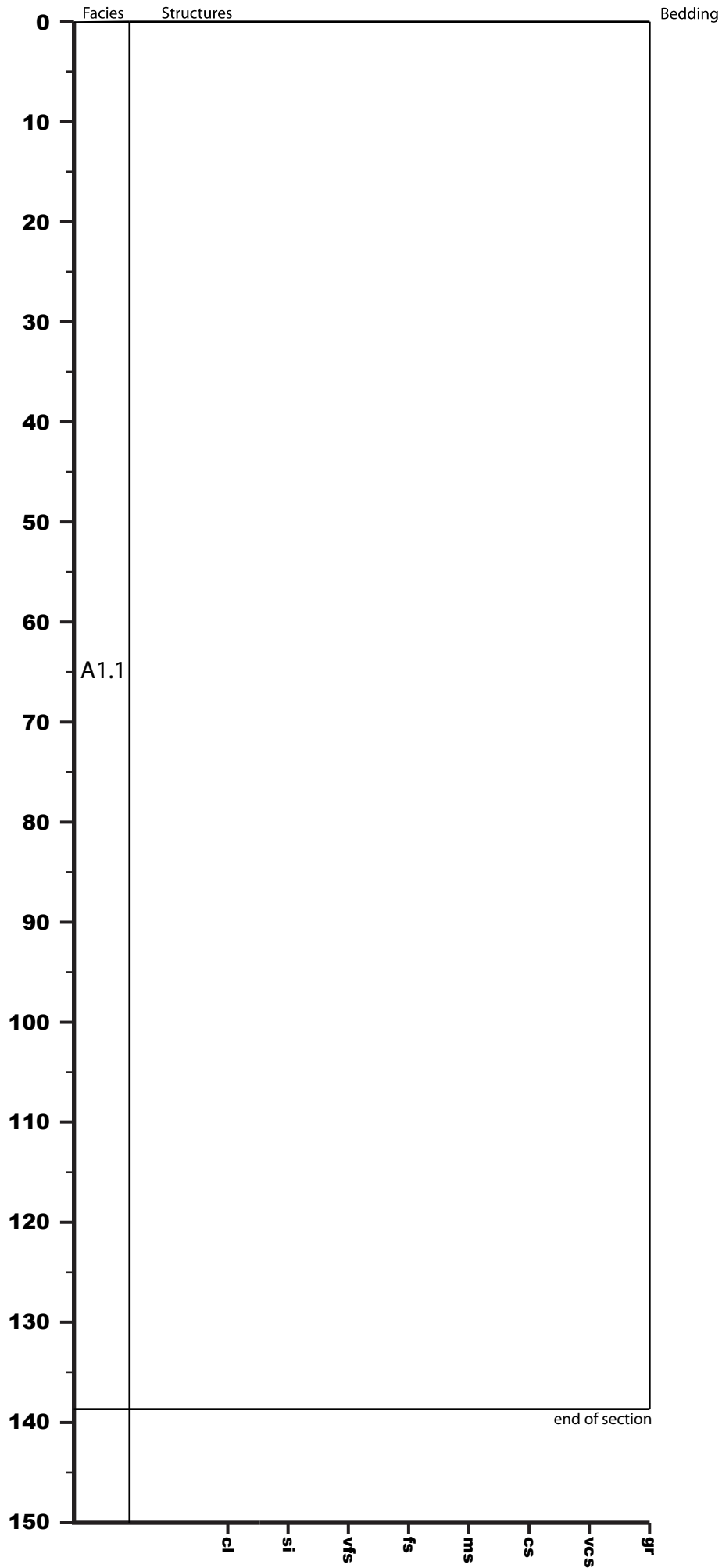



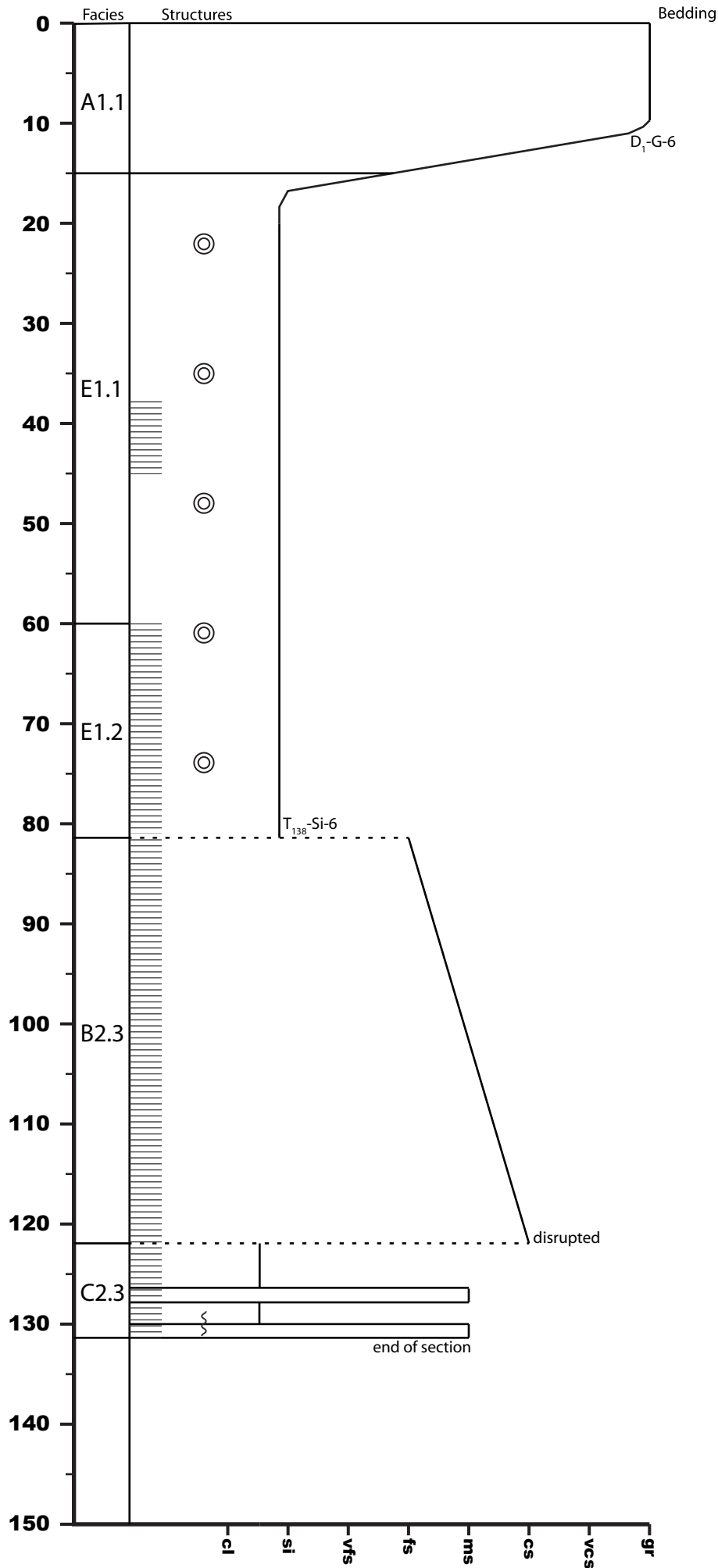

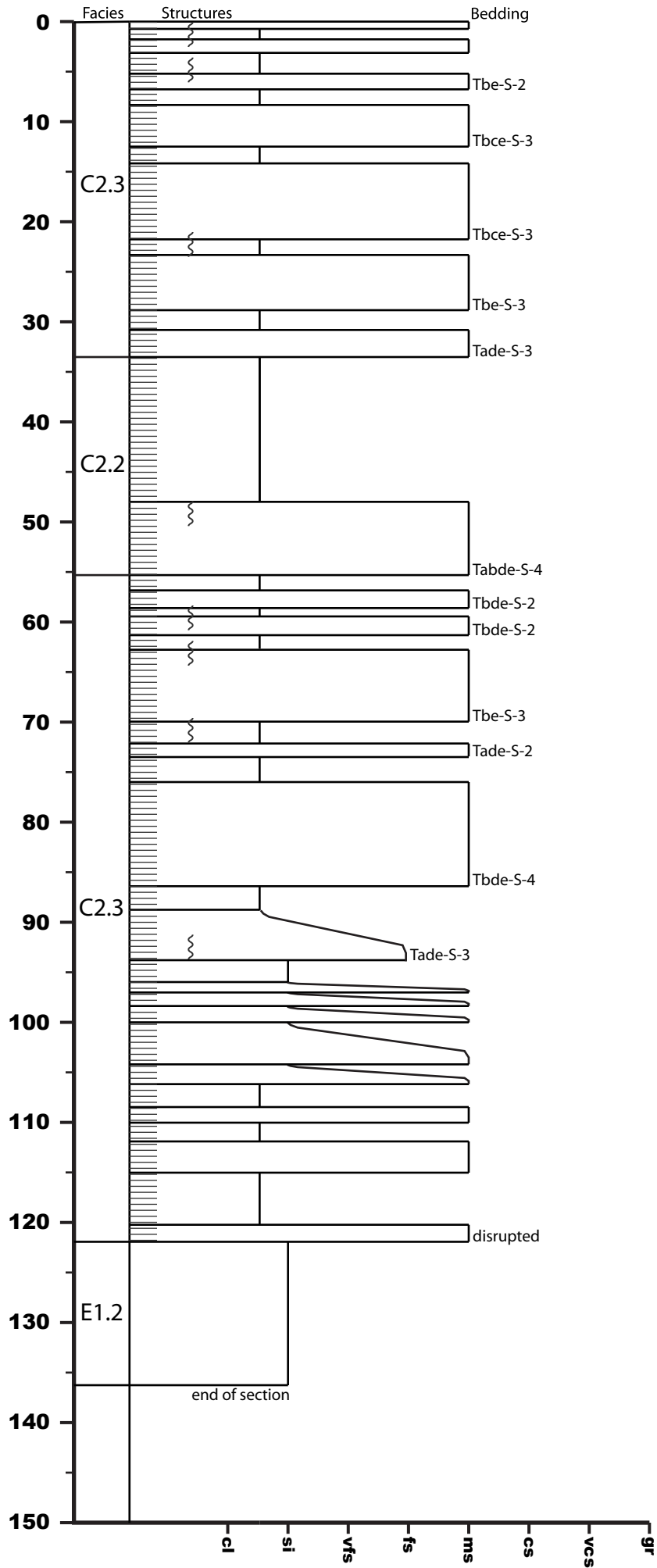

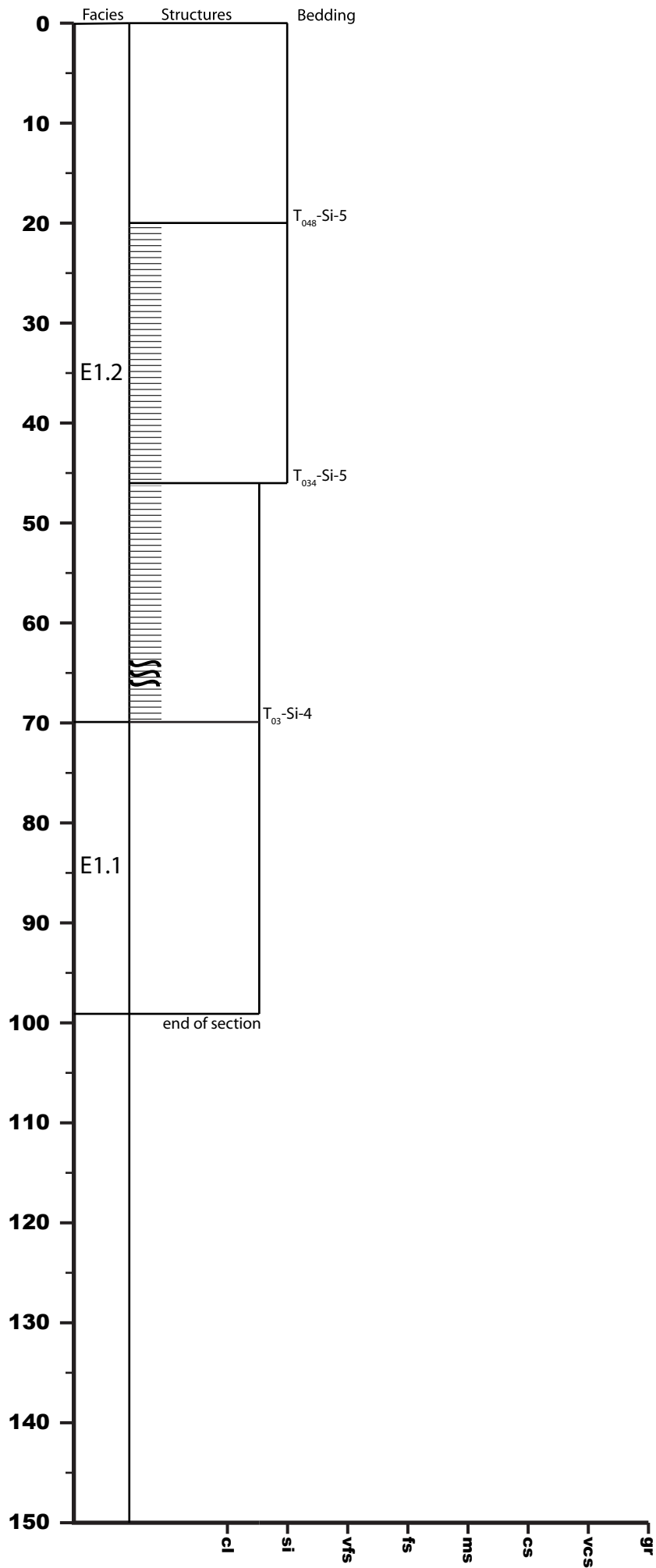

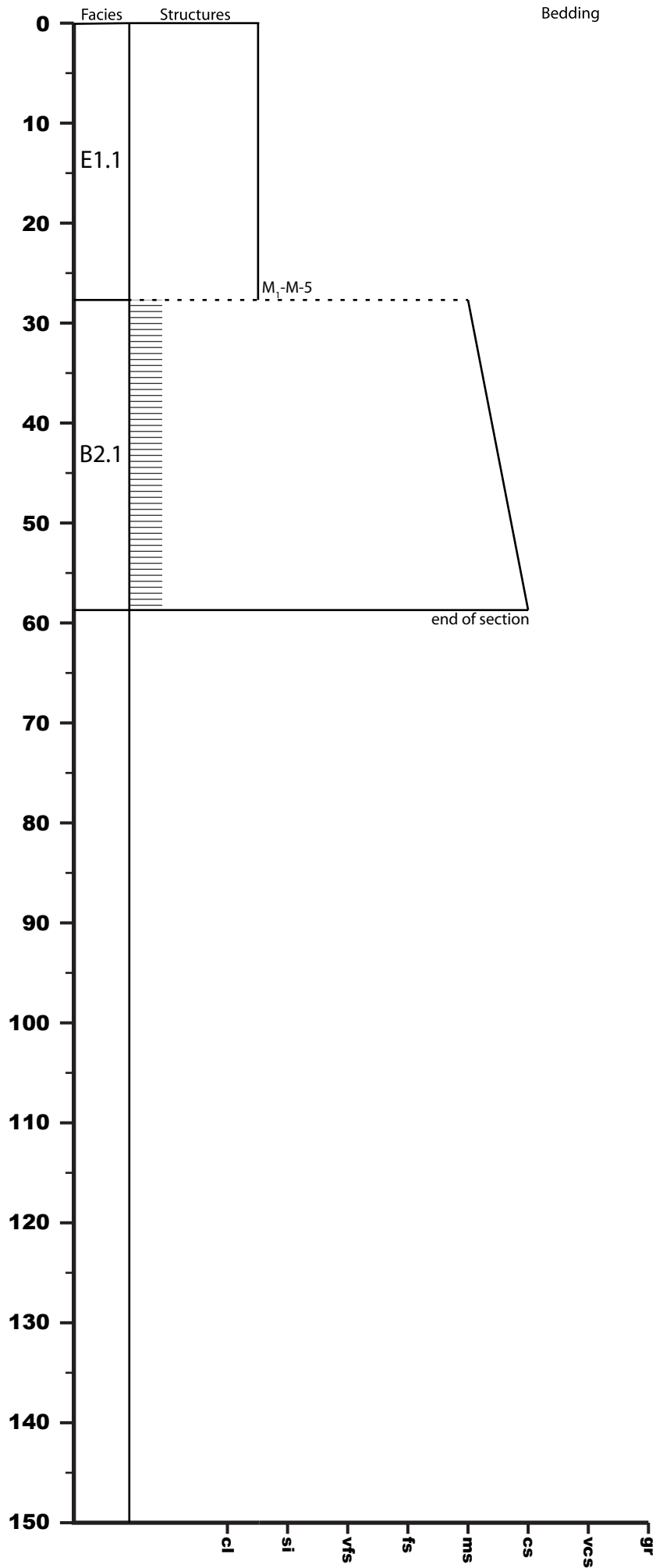

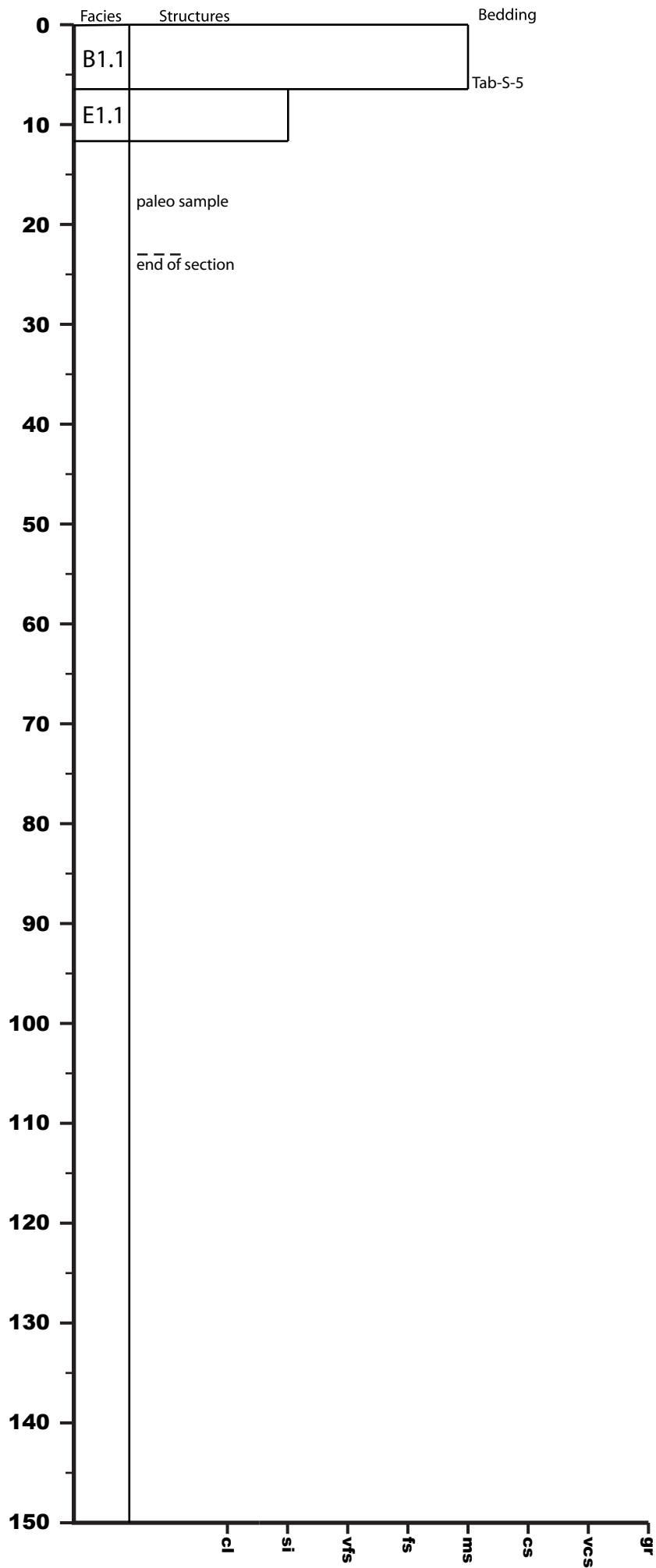

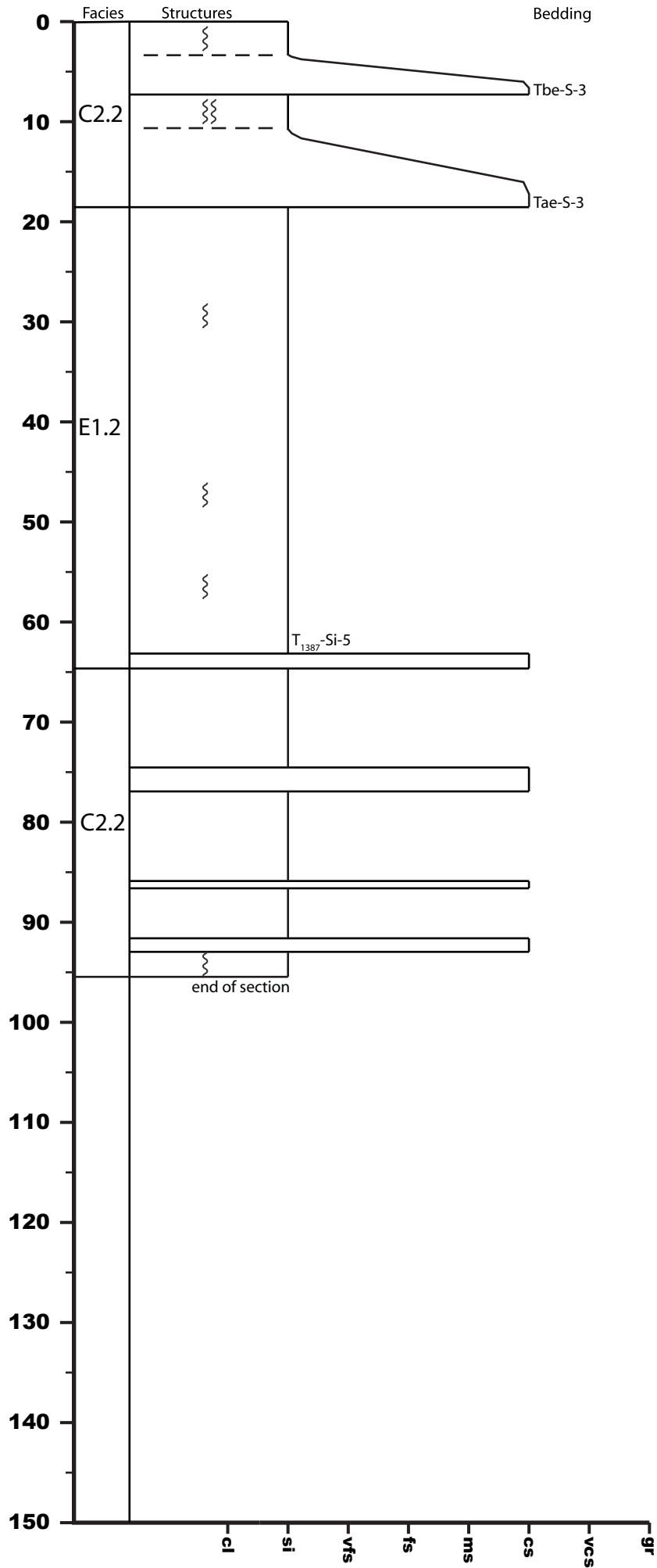

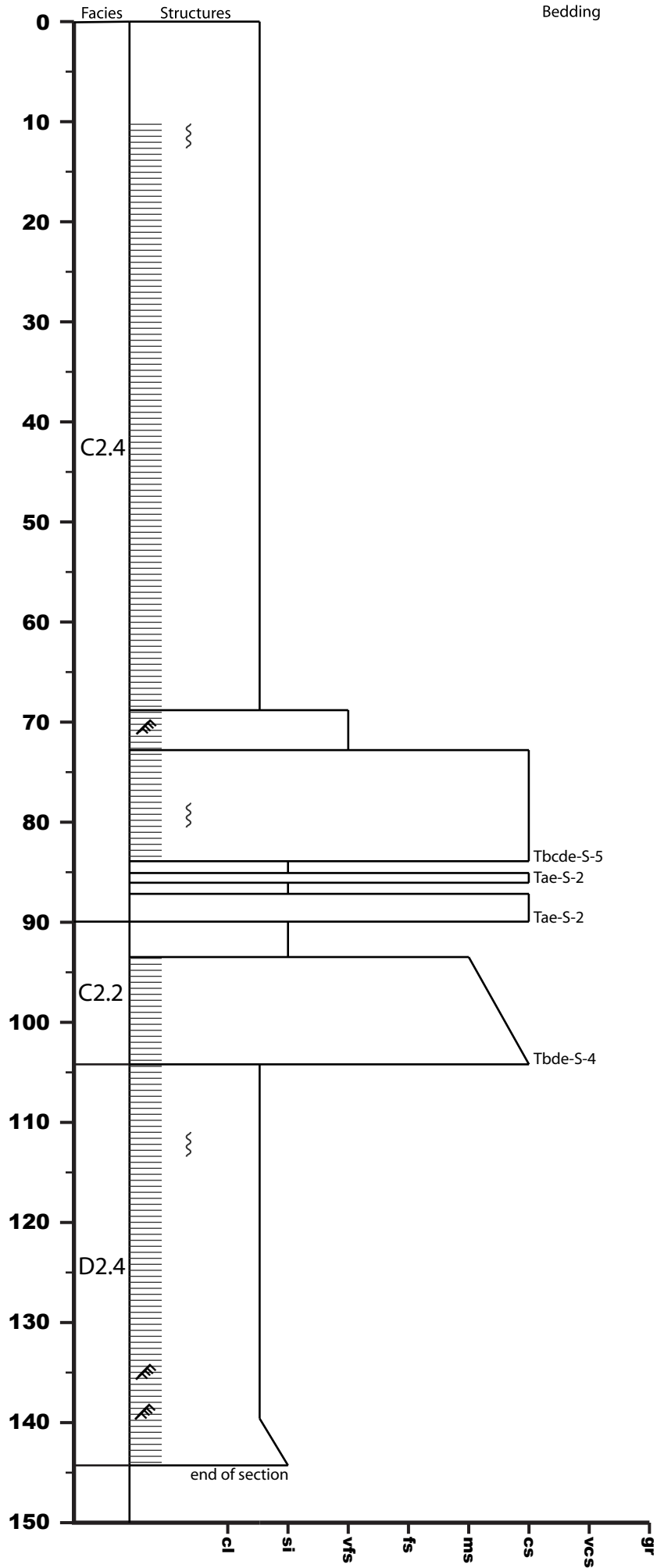

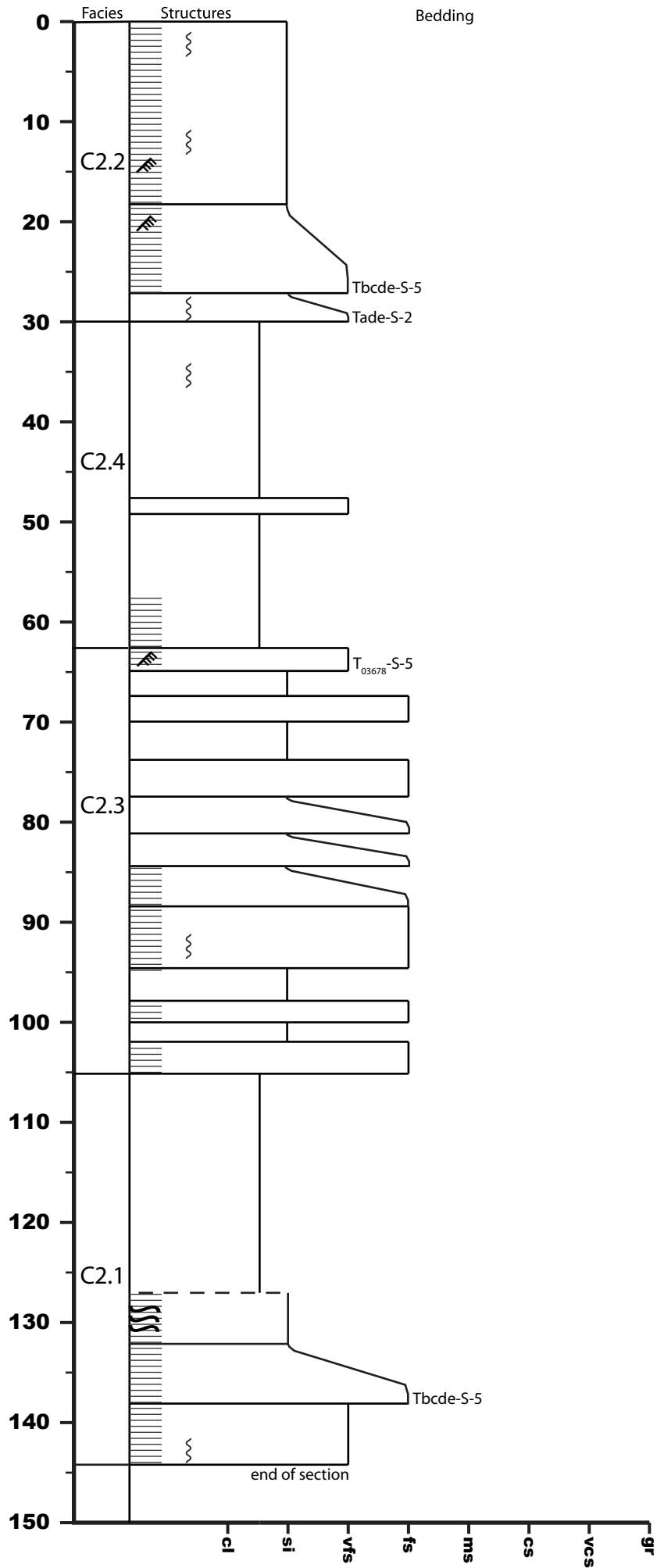



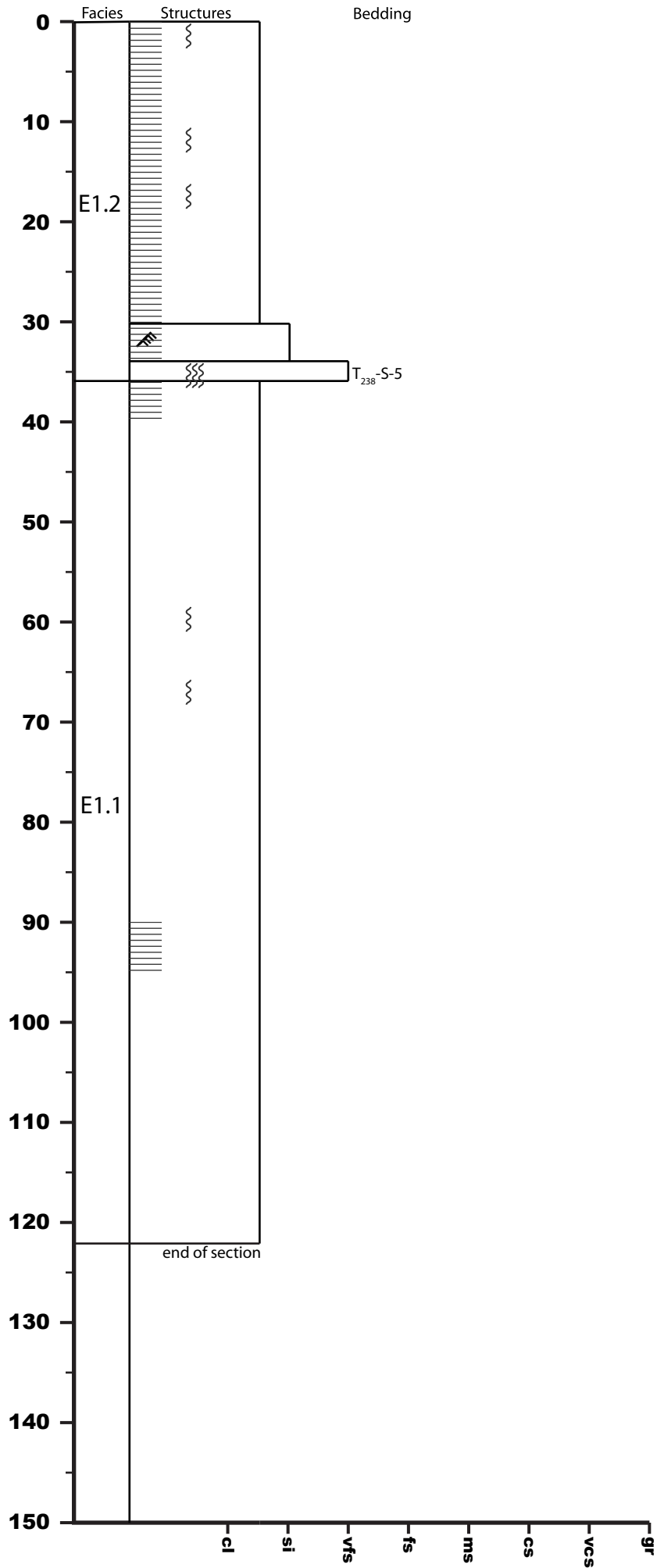

U1438E-45R-5

1267 - 1268.44 mbsf

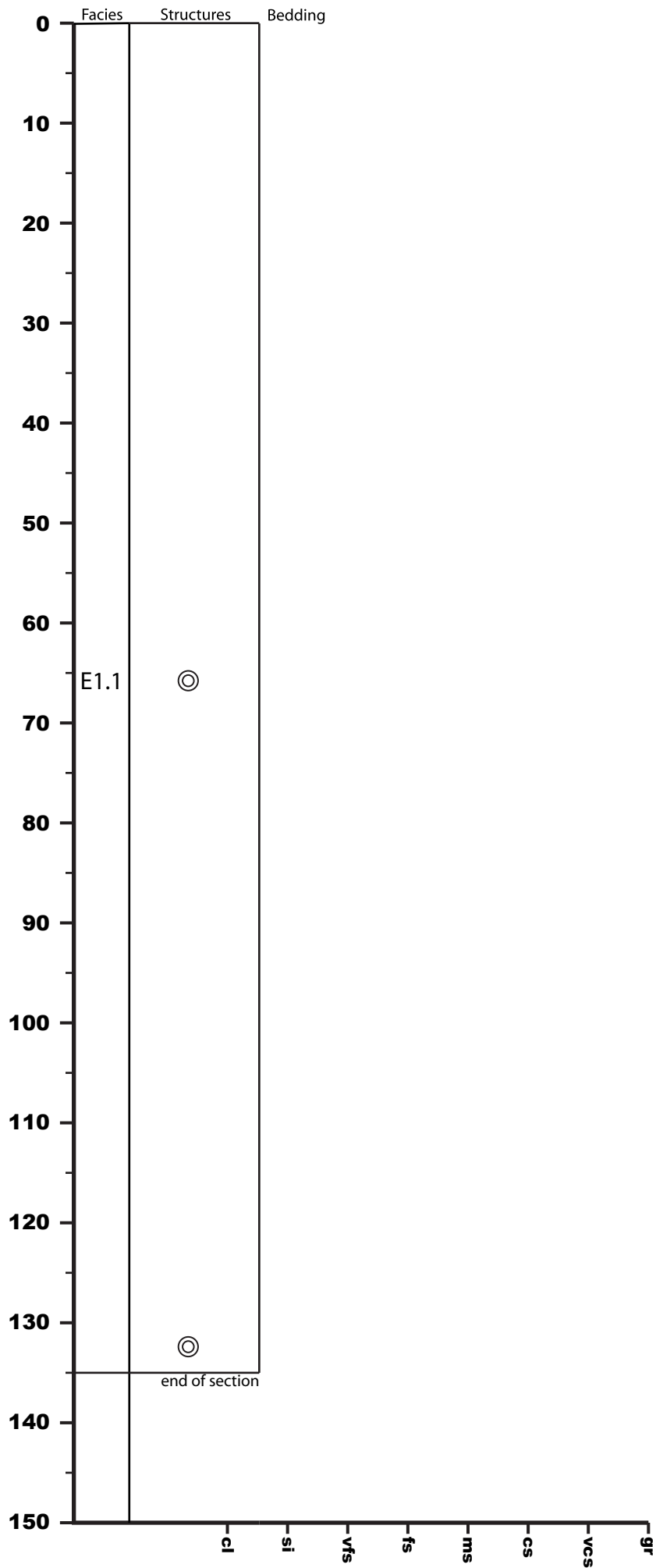

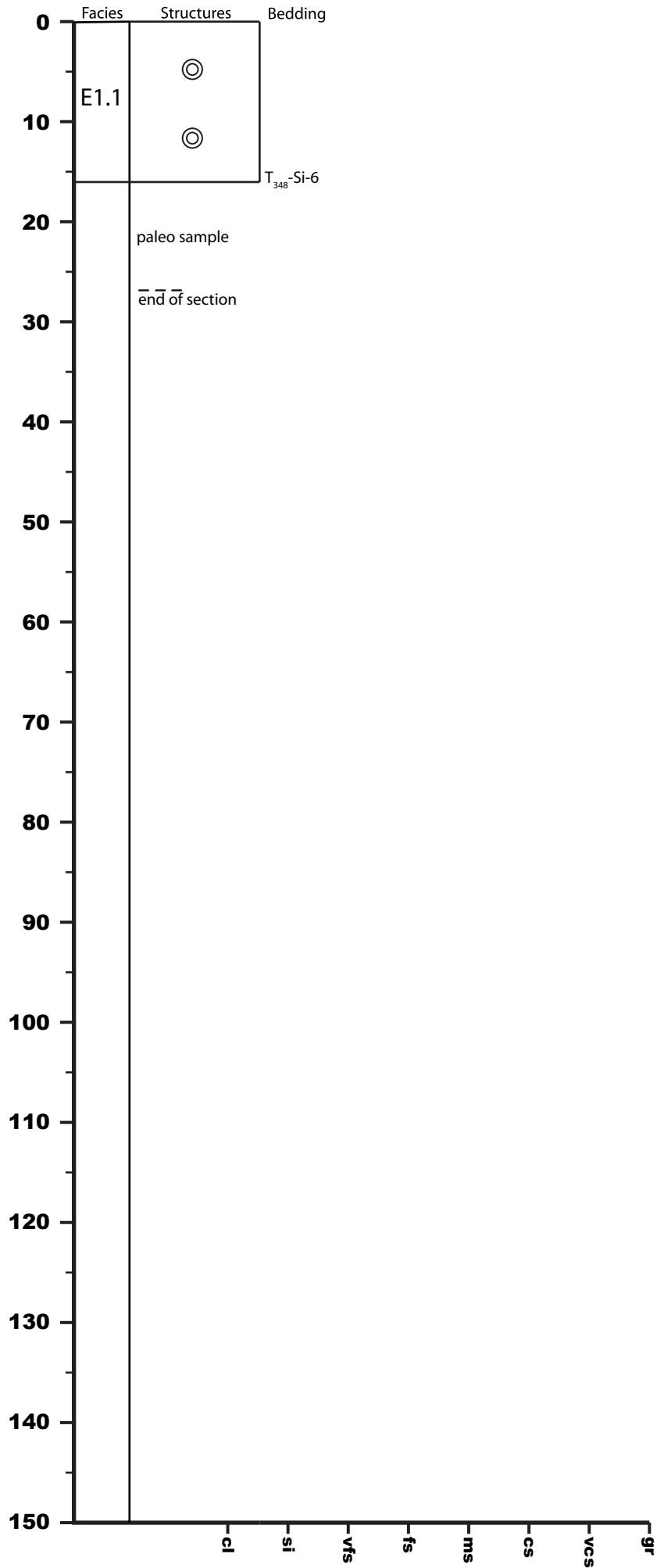

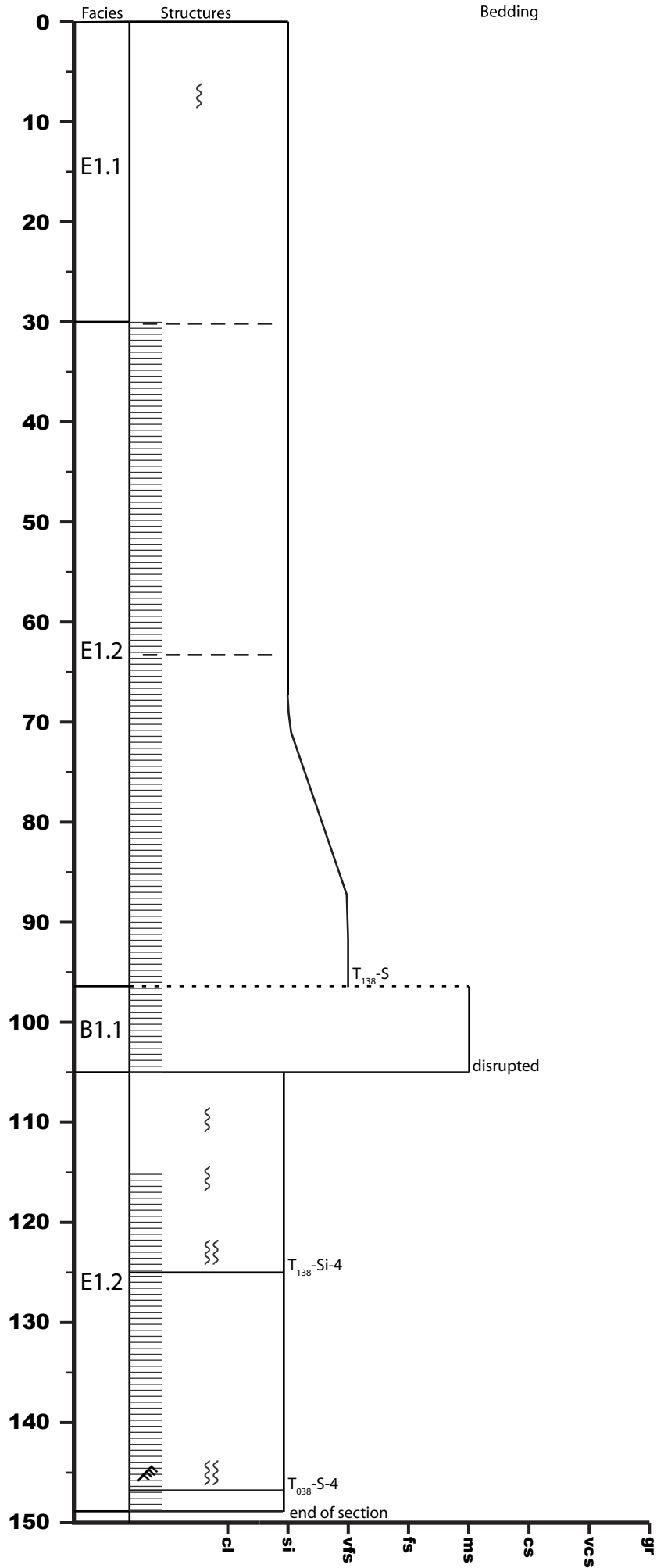

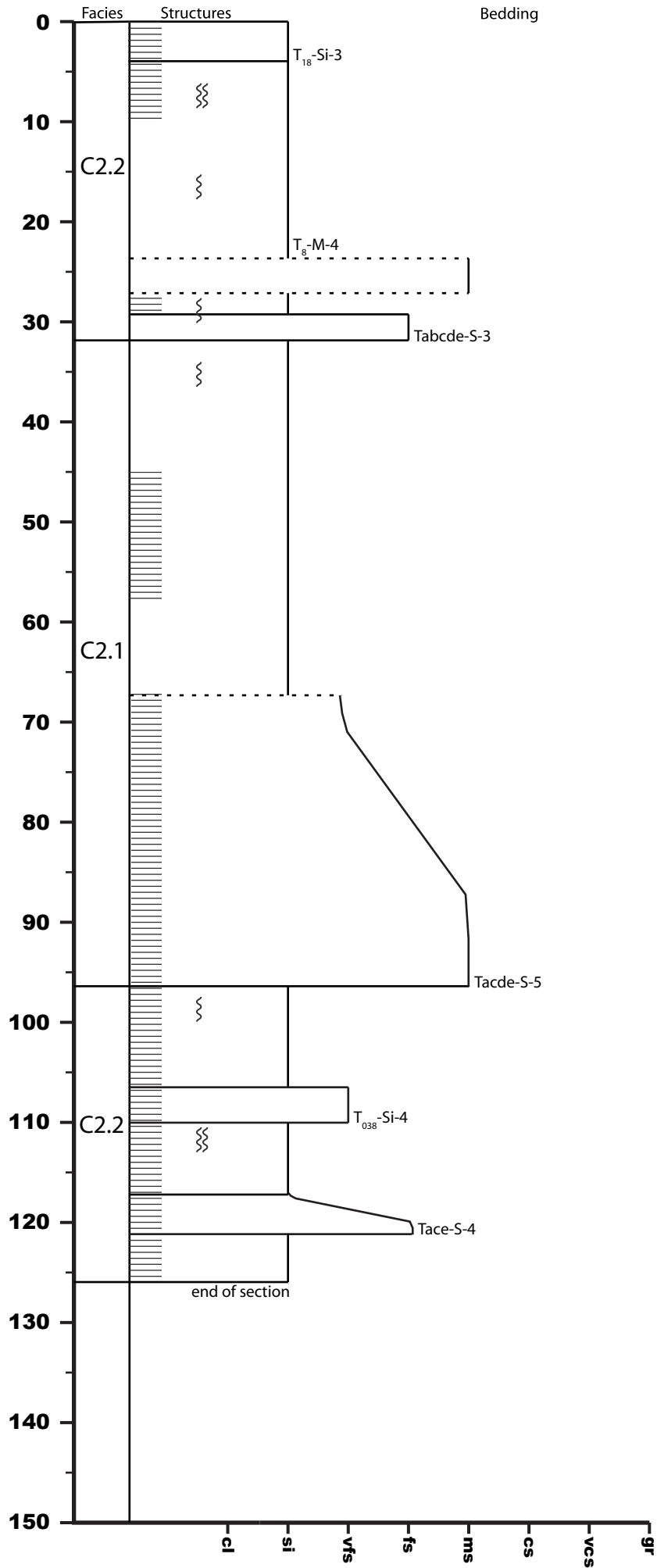

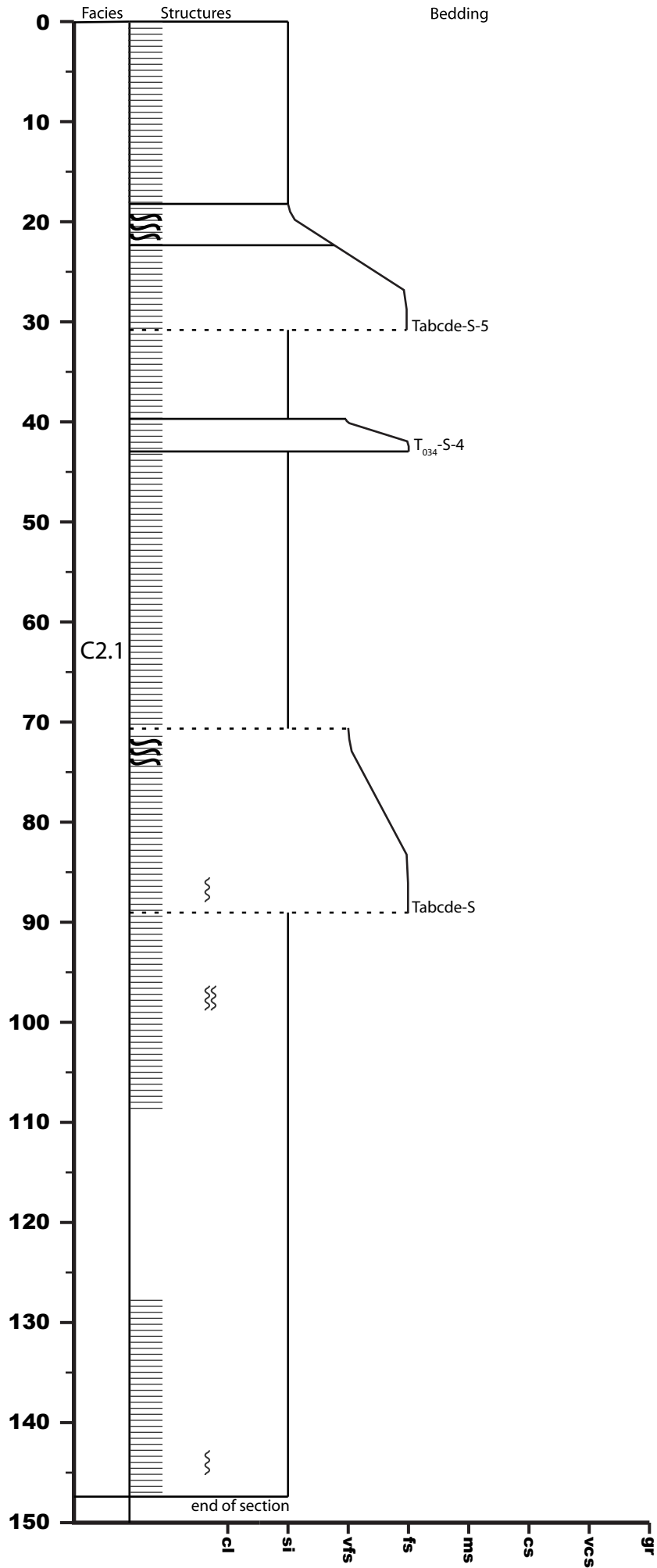

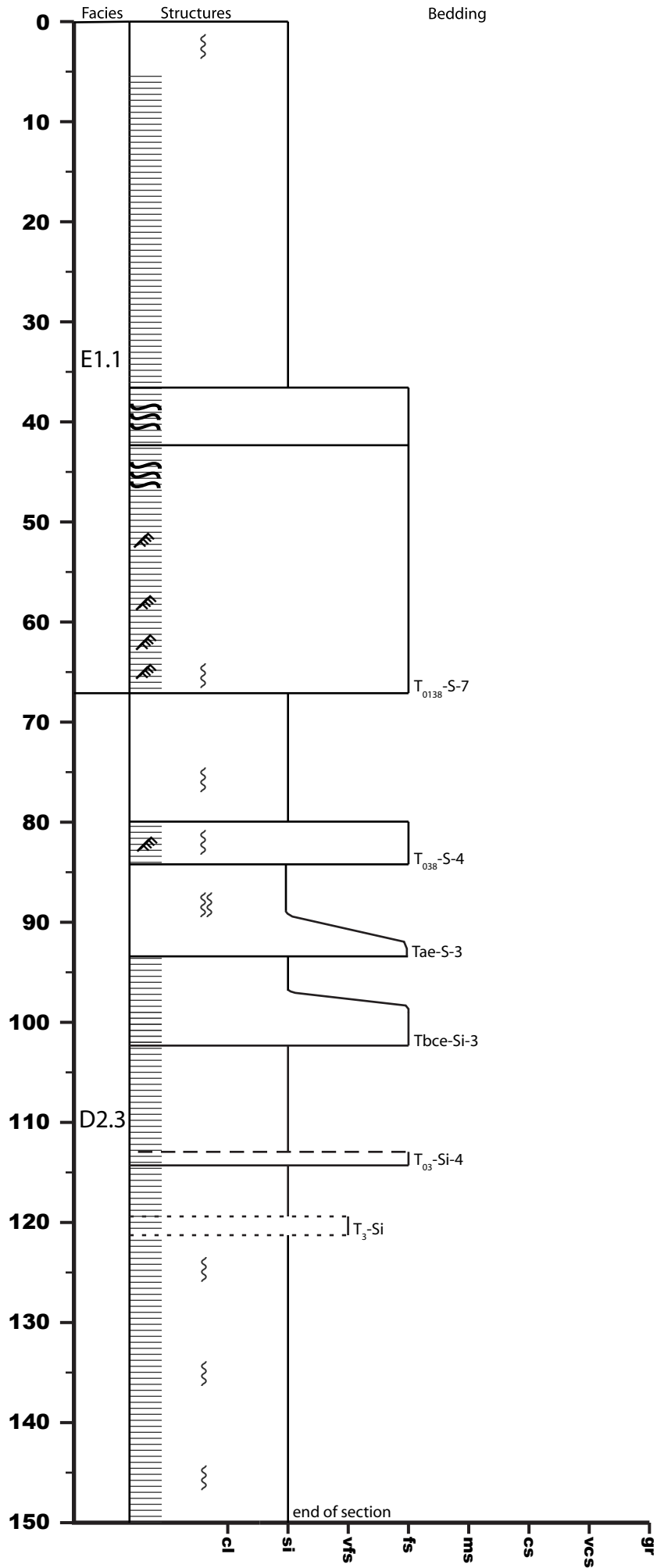

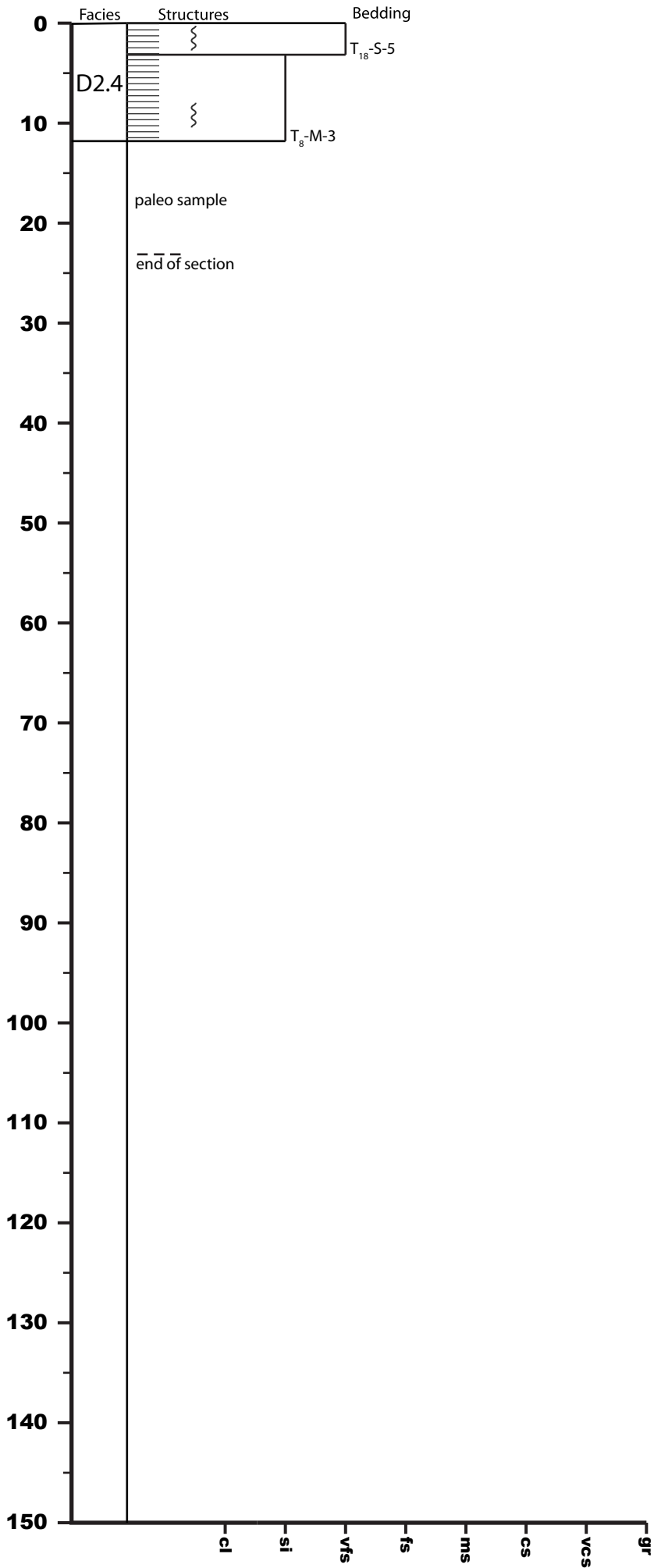



U1438E-47R-1

1283 - 1284.5 mbsf

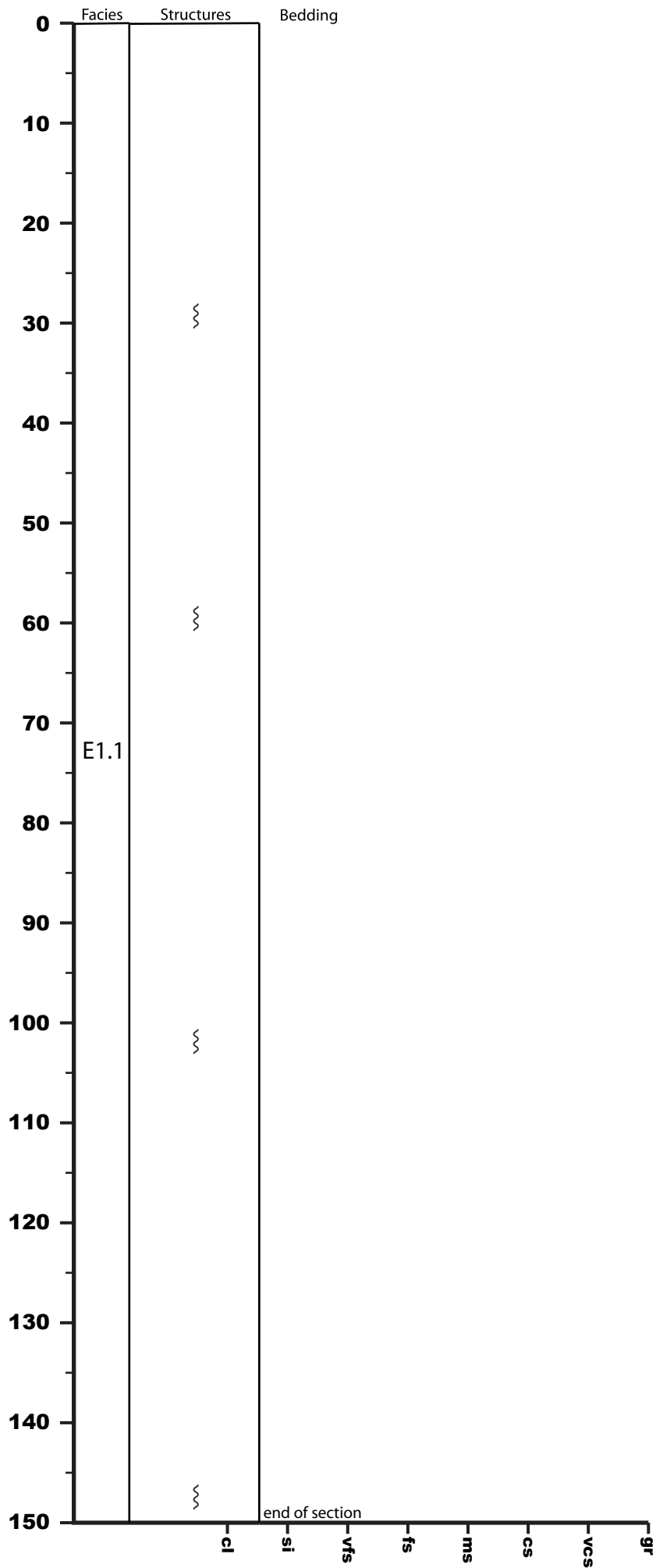

U1438E-47R-2

1284.5 - 1285.84 mbsf

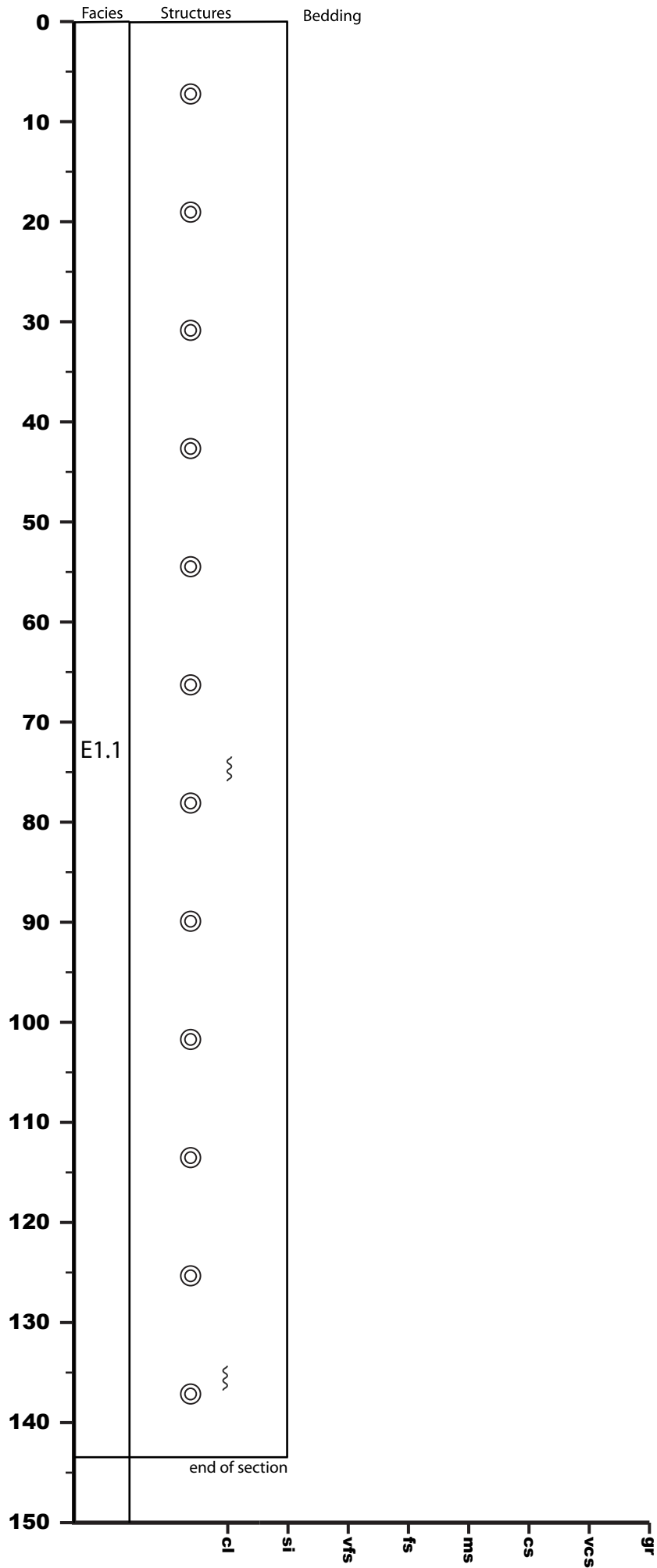

U1438E-47R-3

1285.94 - 1286.97 mbsf

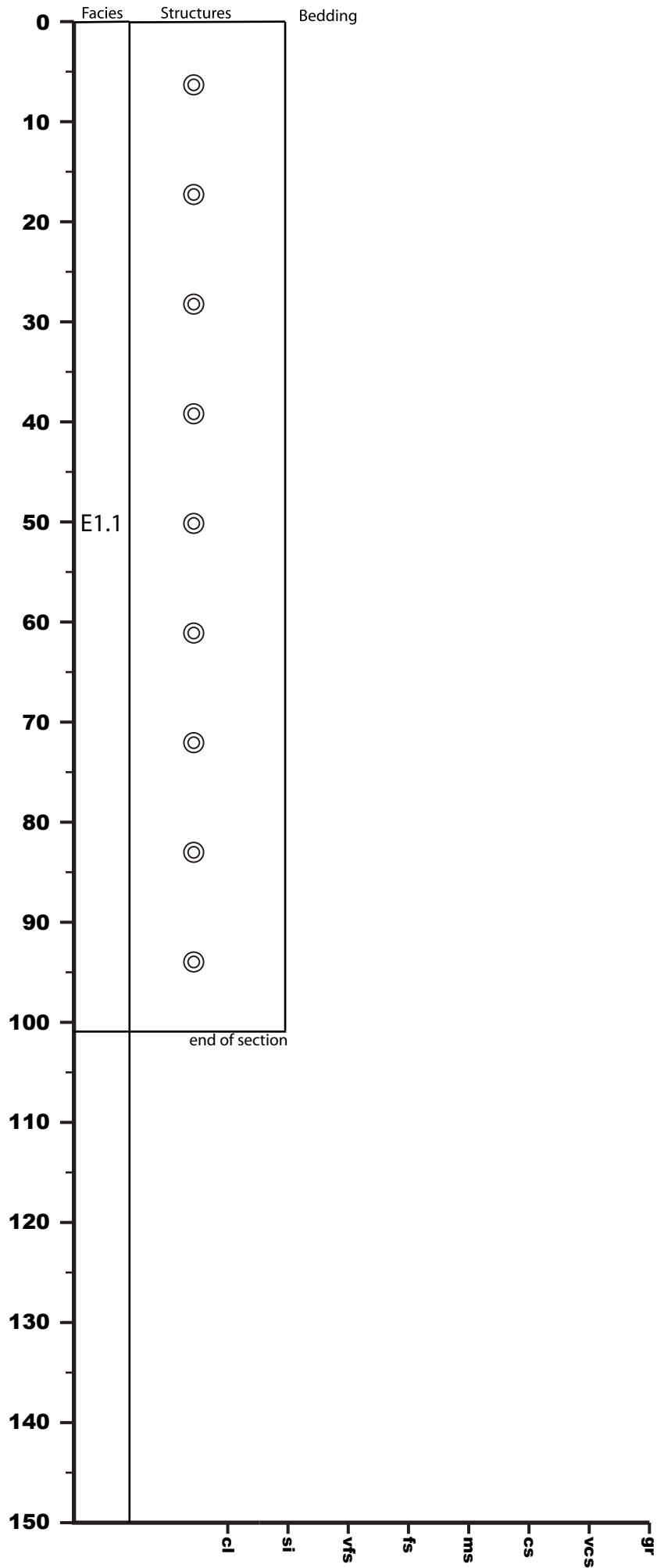

U1438E-47R-4

1286.97 - 1288.48 mbsf

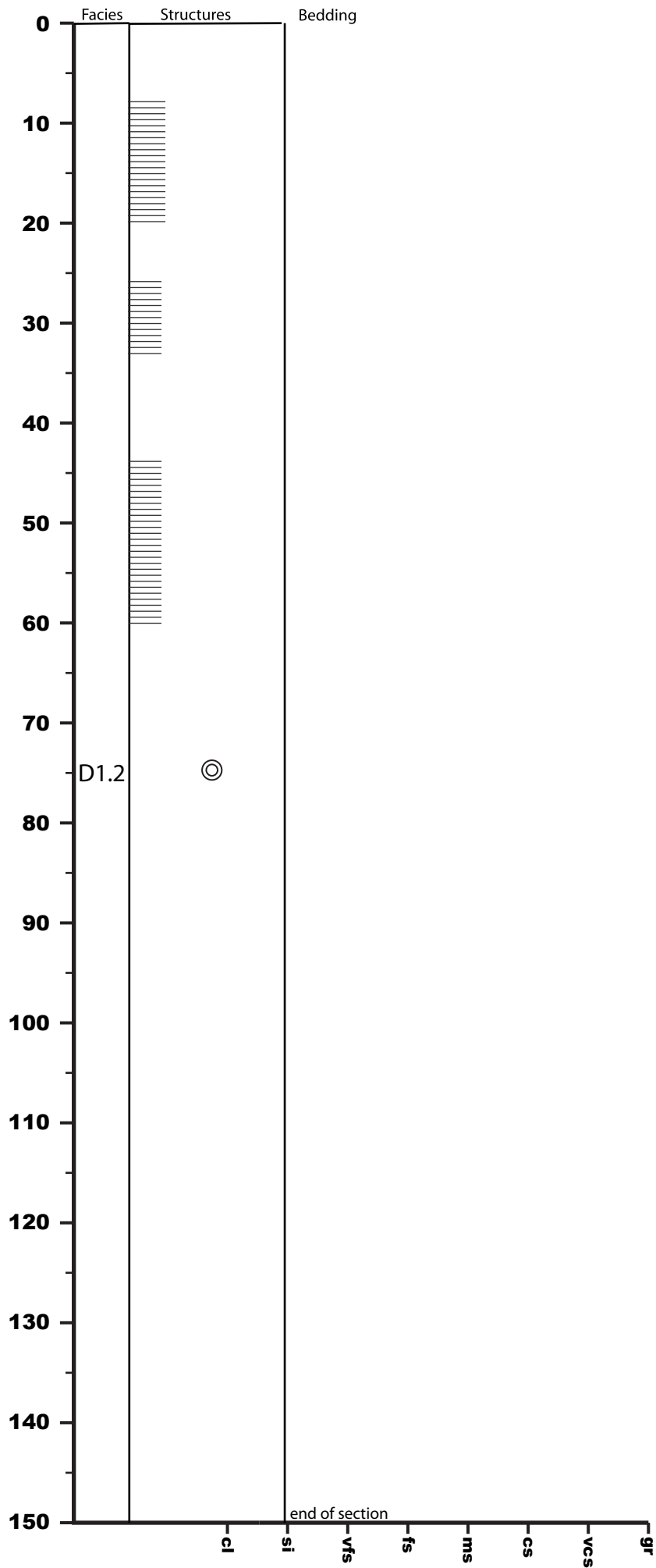

U1438E-47R-5

1288.48 - 1289.69 mbsf

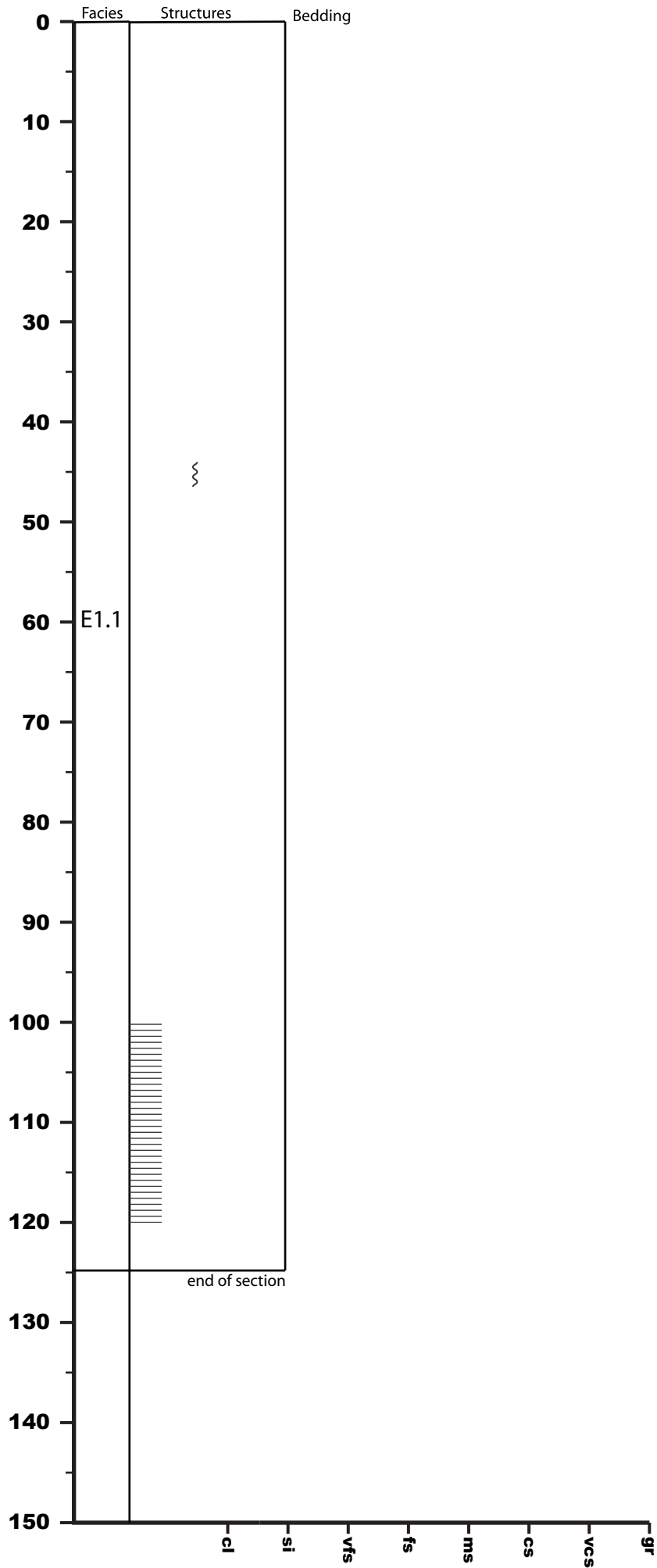

U1438E-47R-6

1289.69 - 1290.4 mbsf

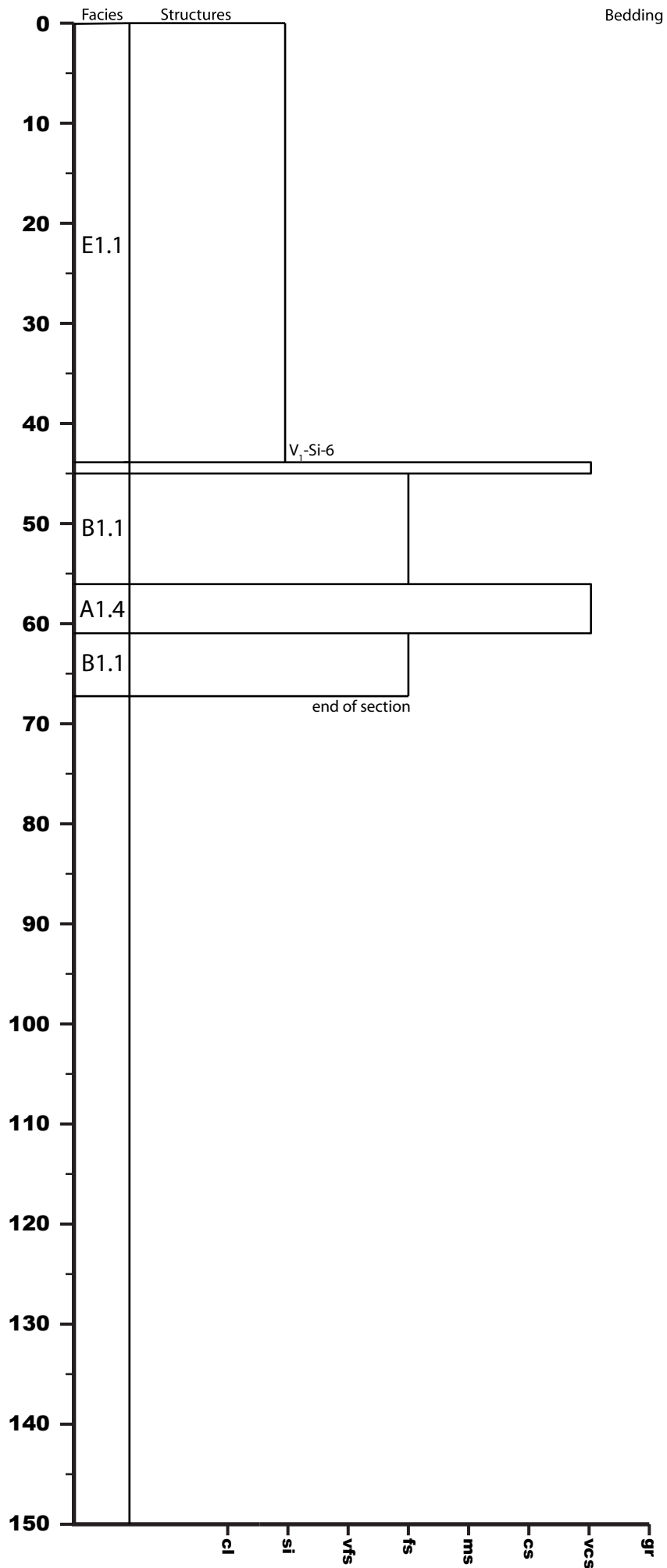

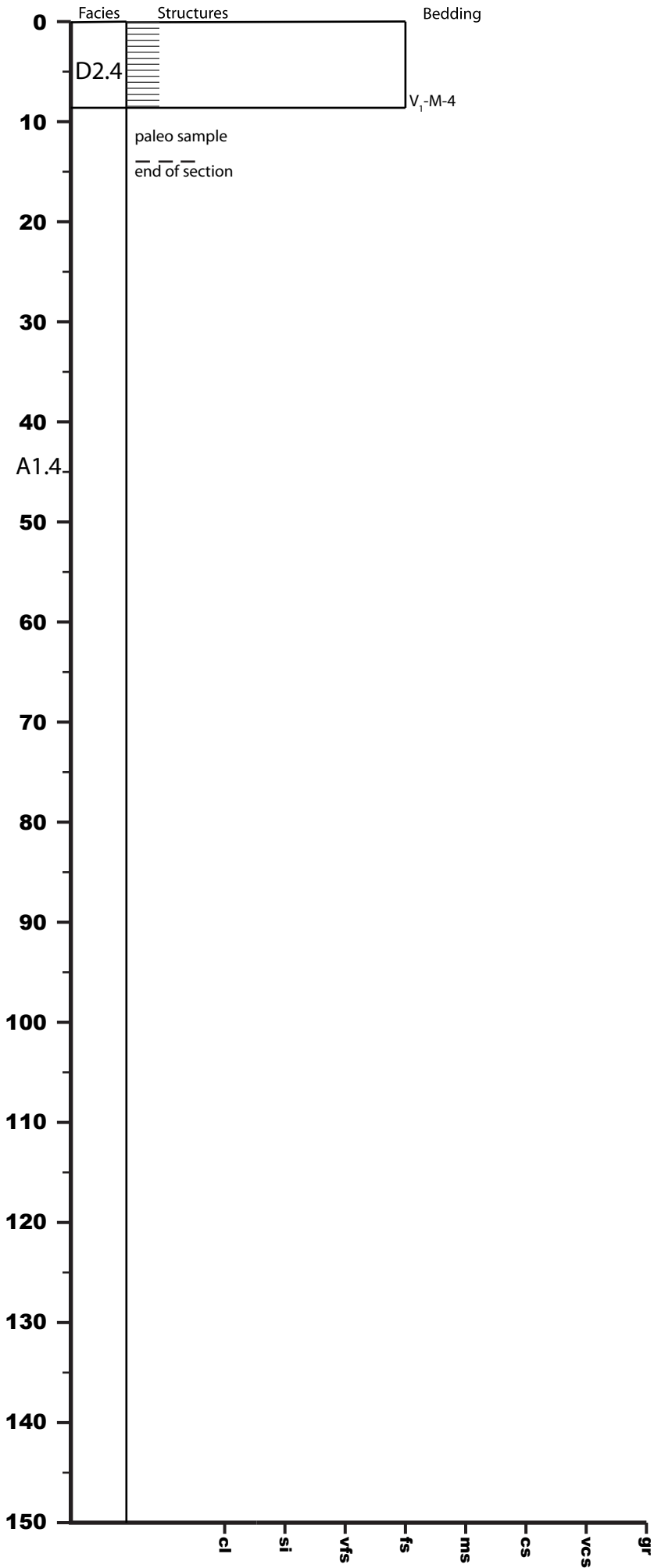

U1438E-48R-1

1292.2 - 1293.23 mbsf

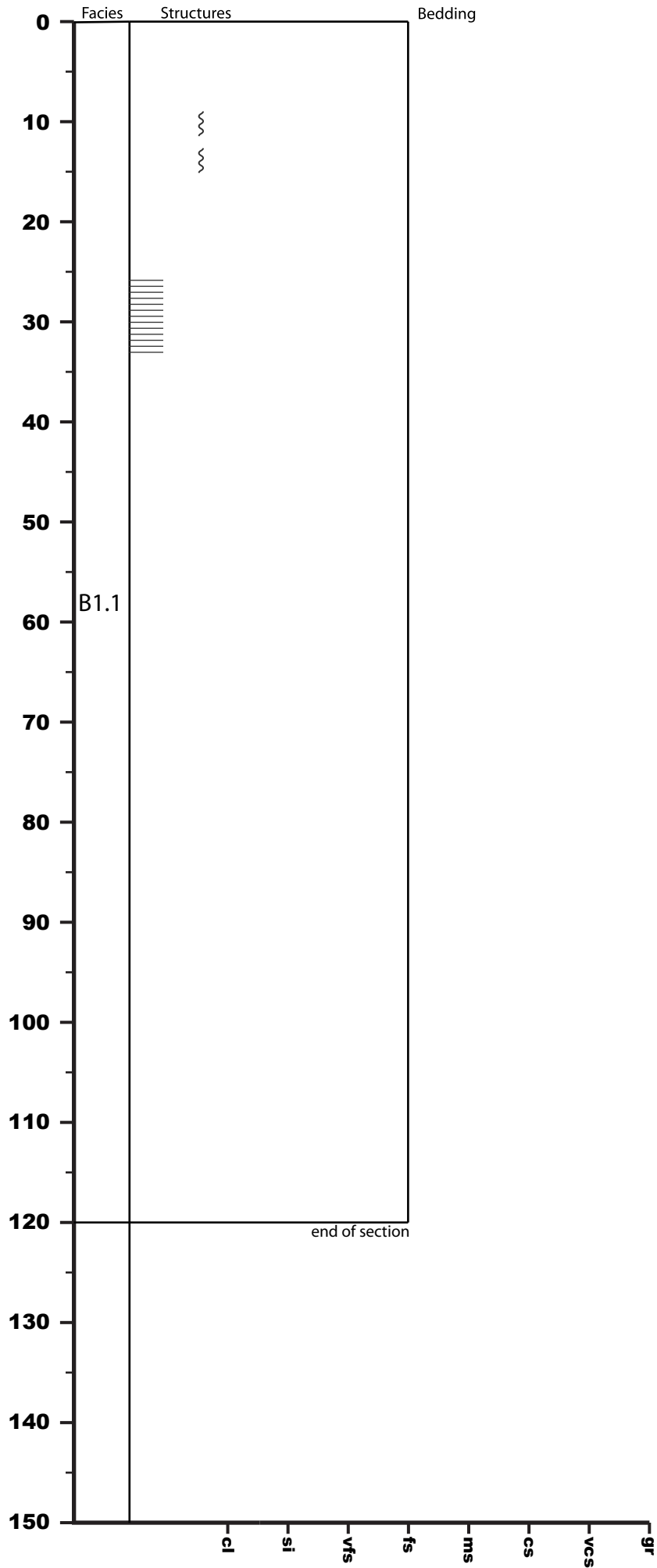



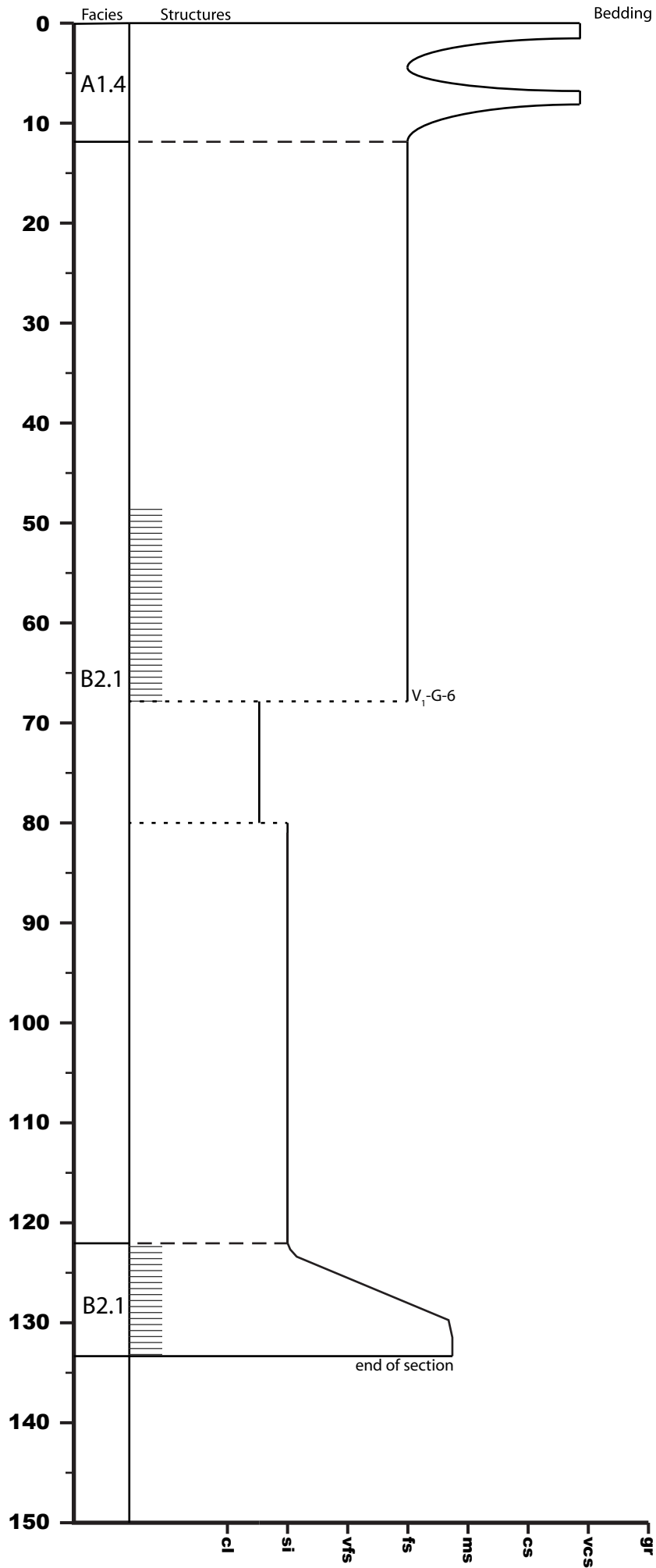

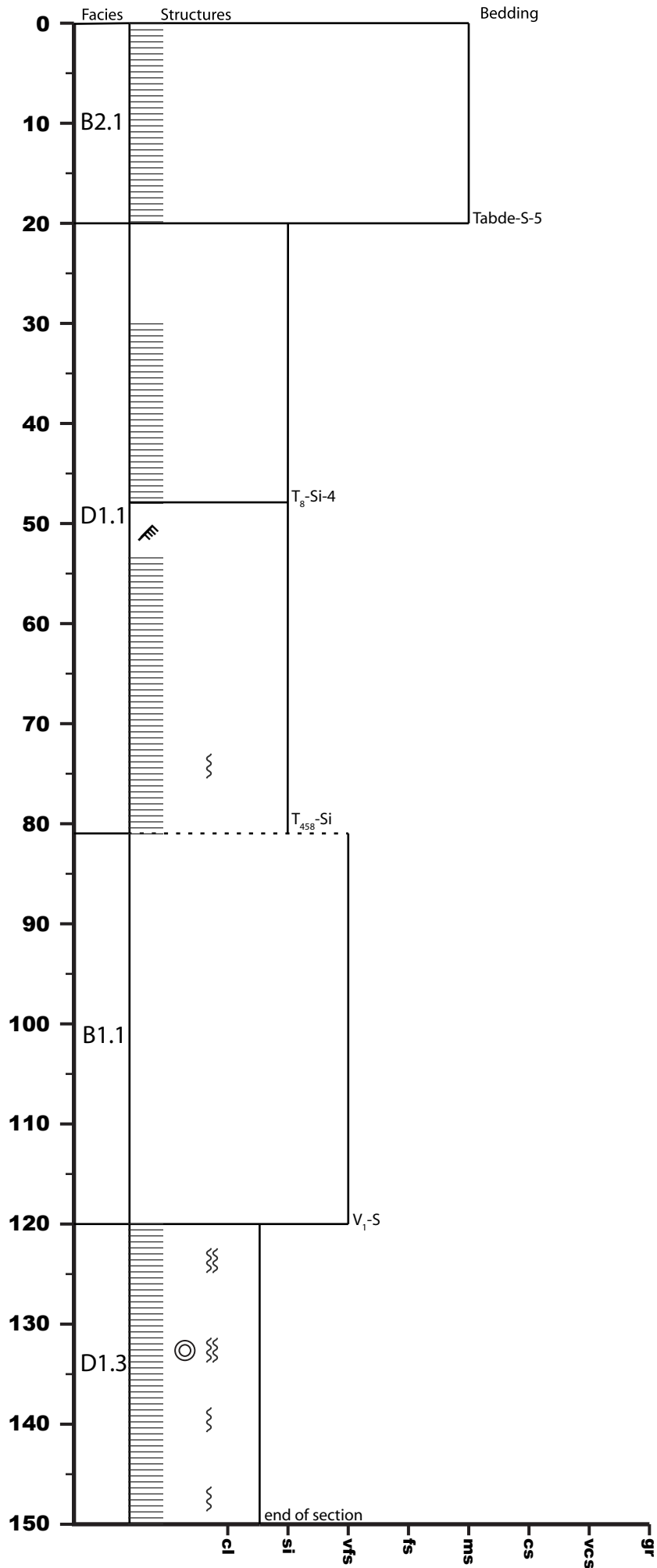

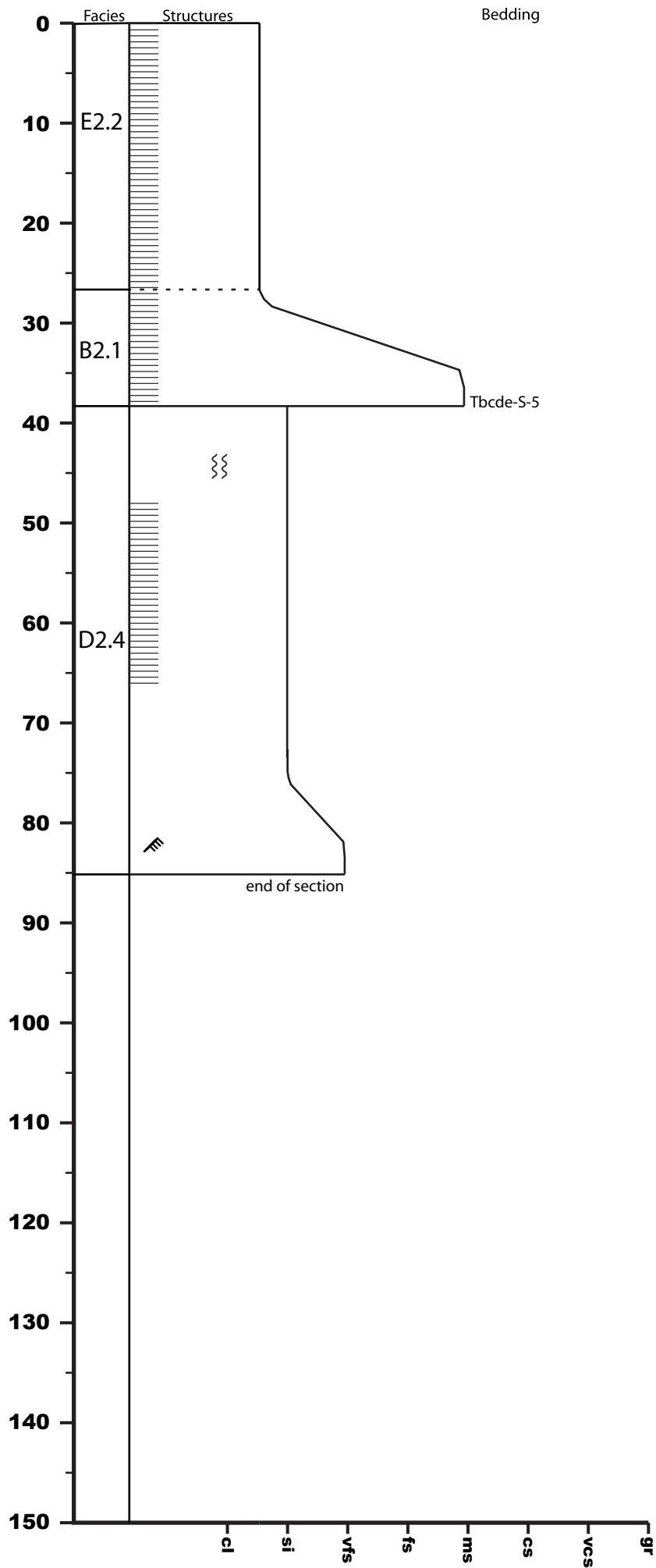

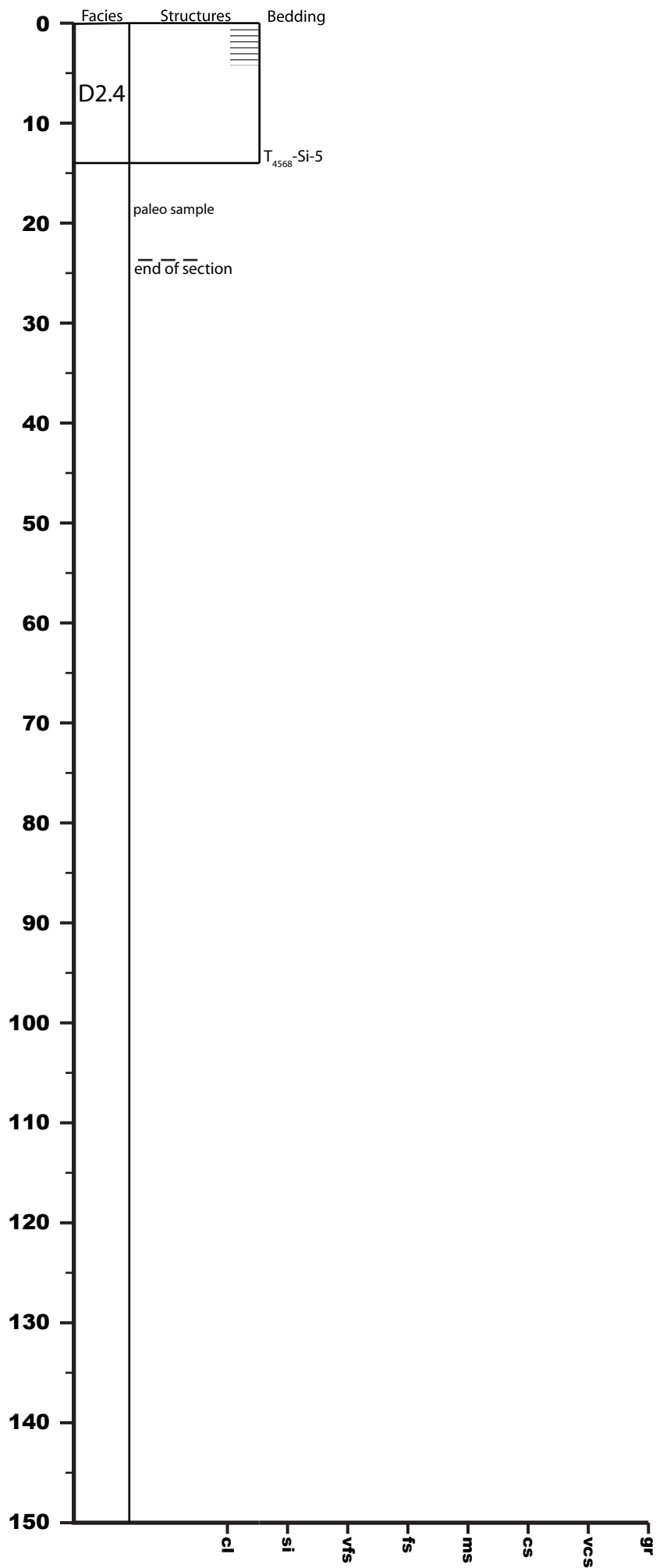

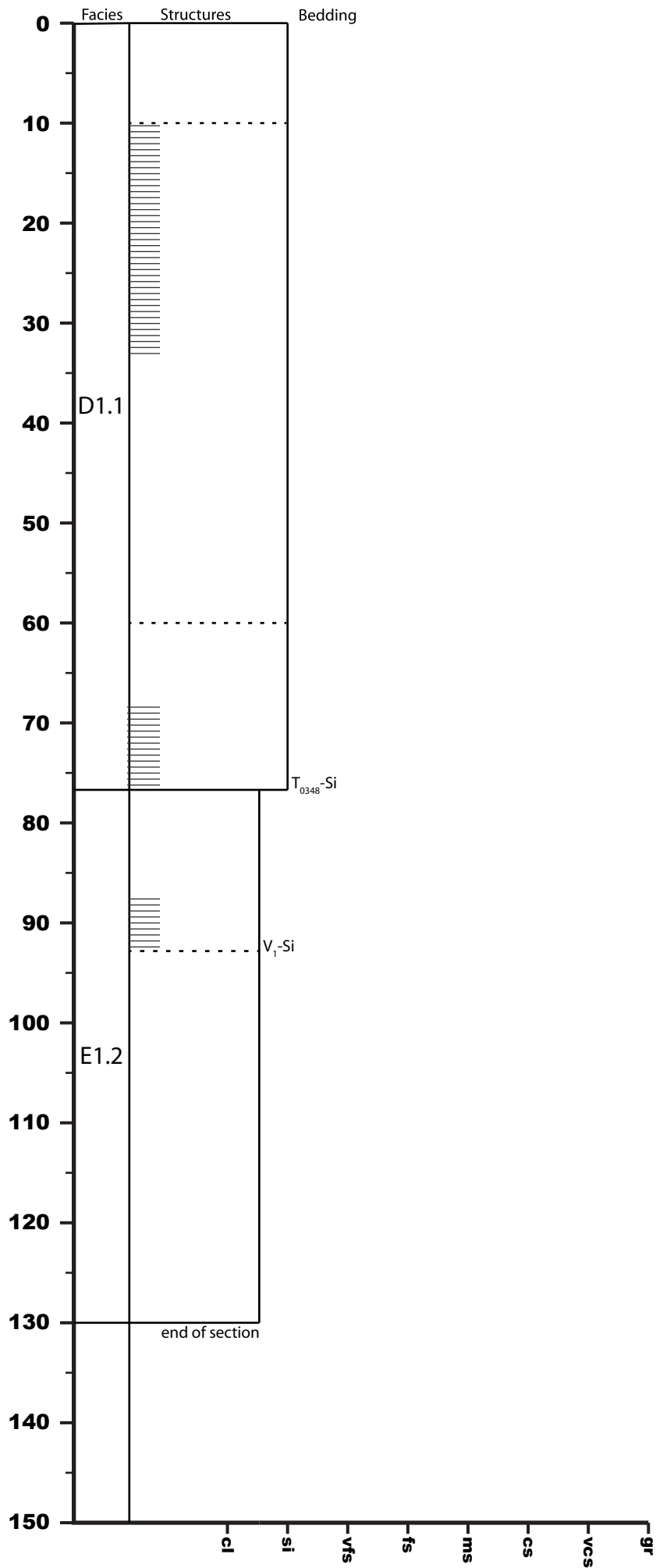

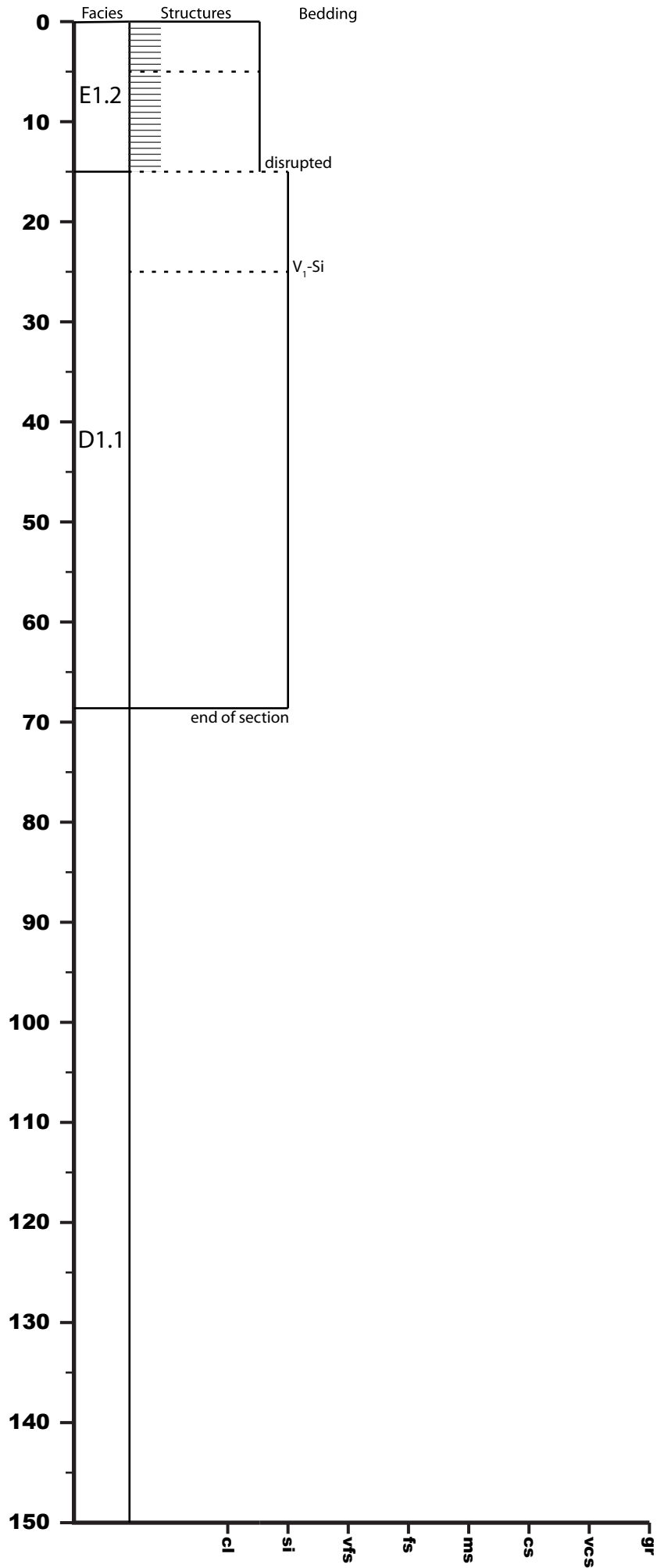

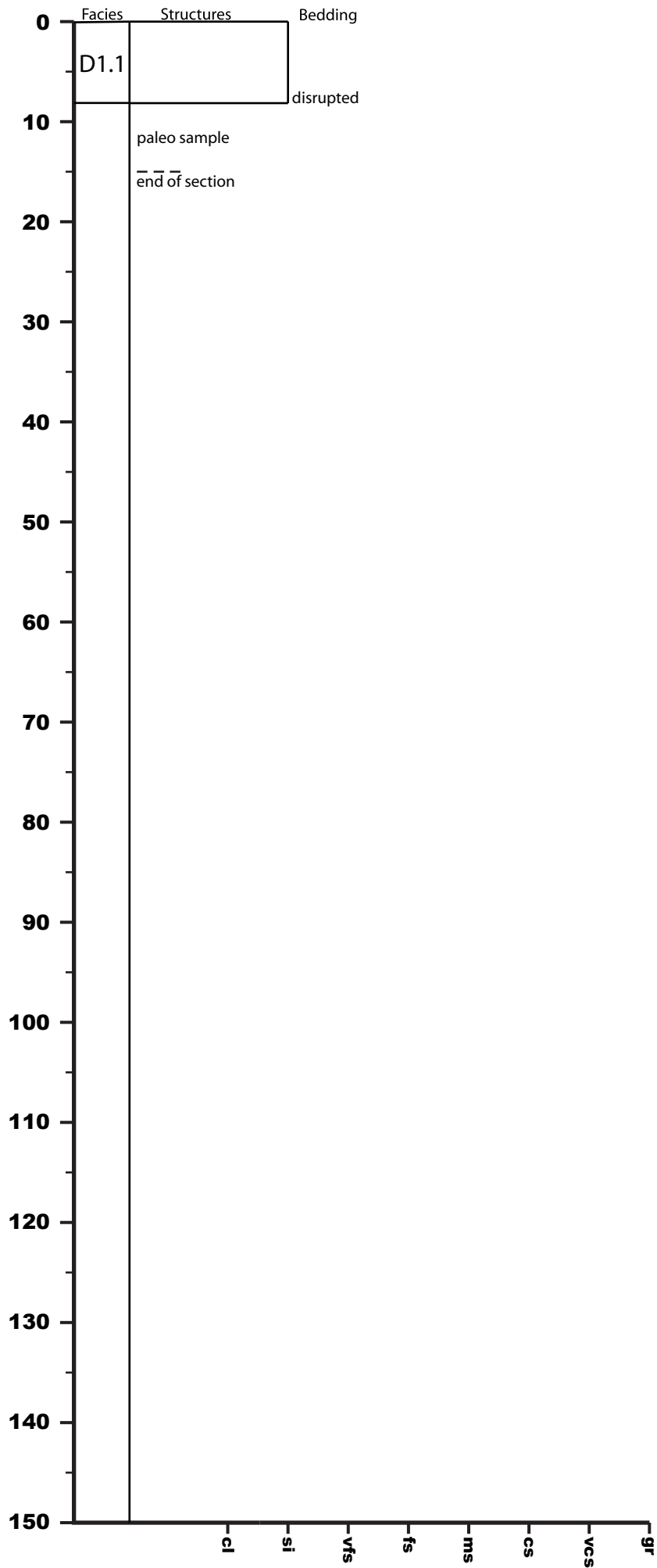

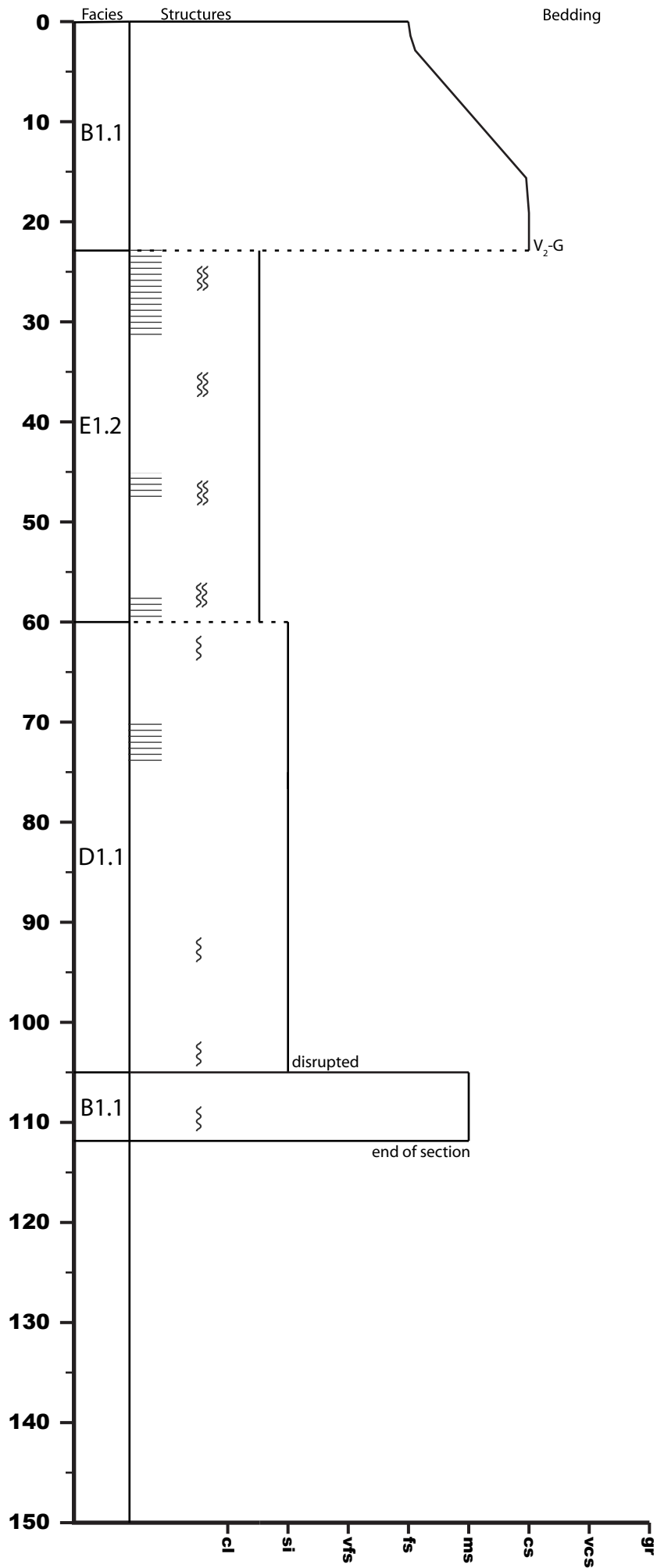



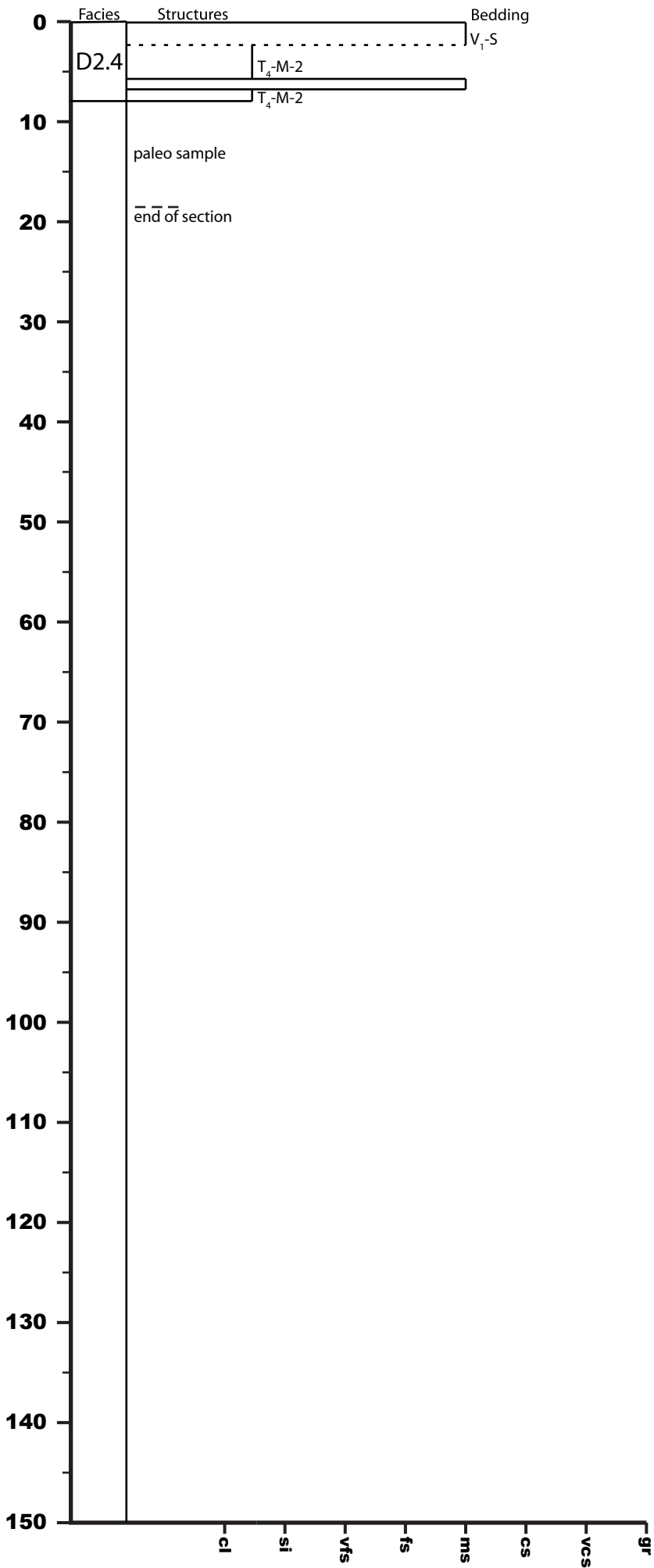

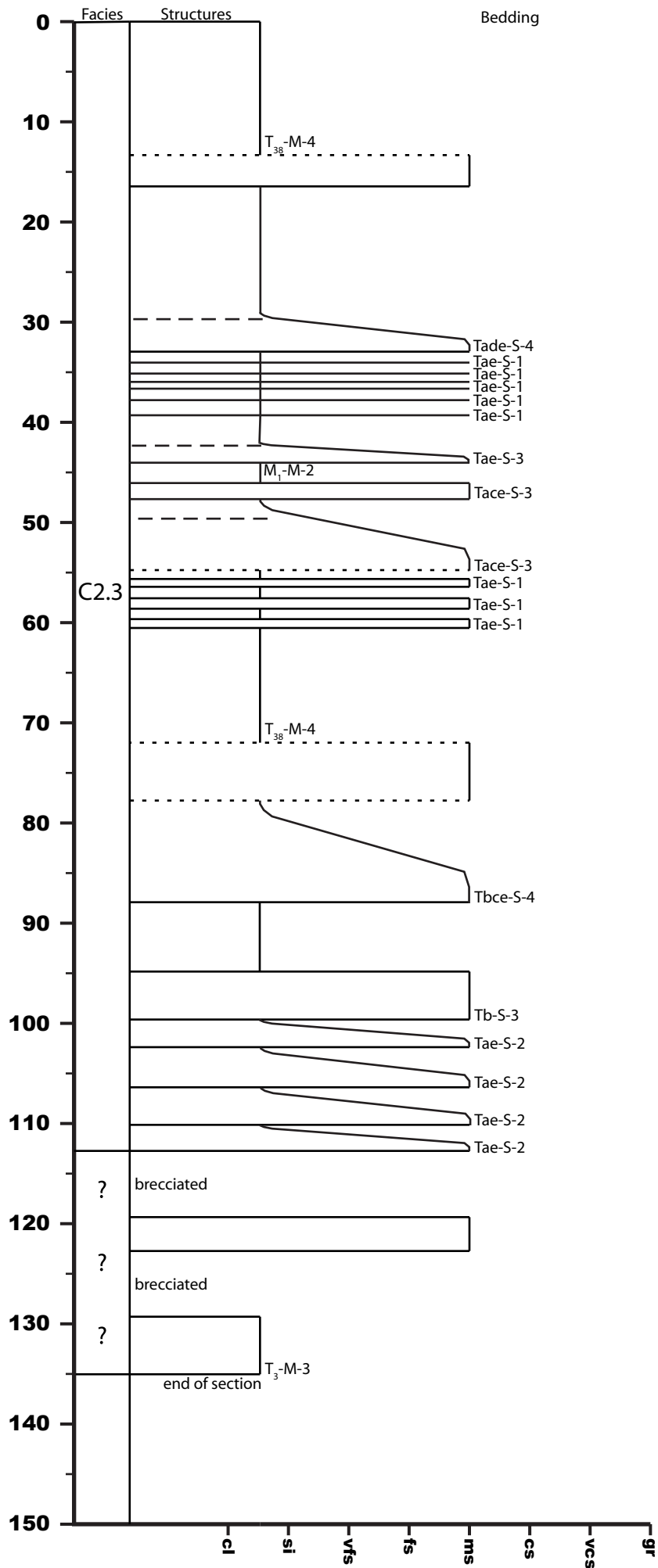

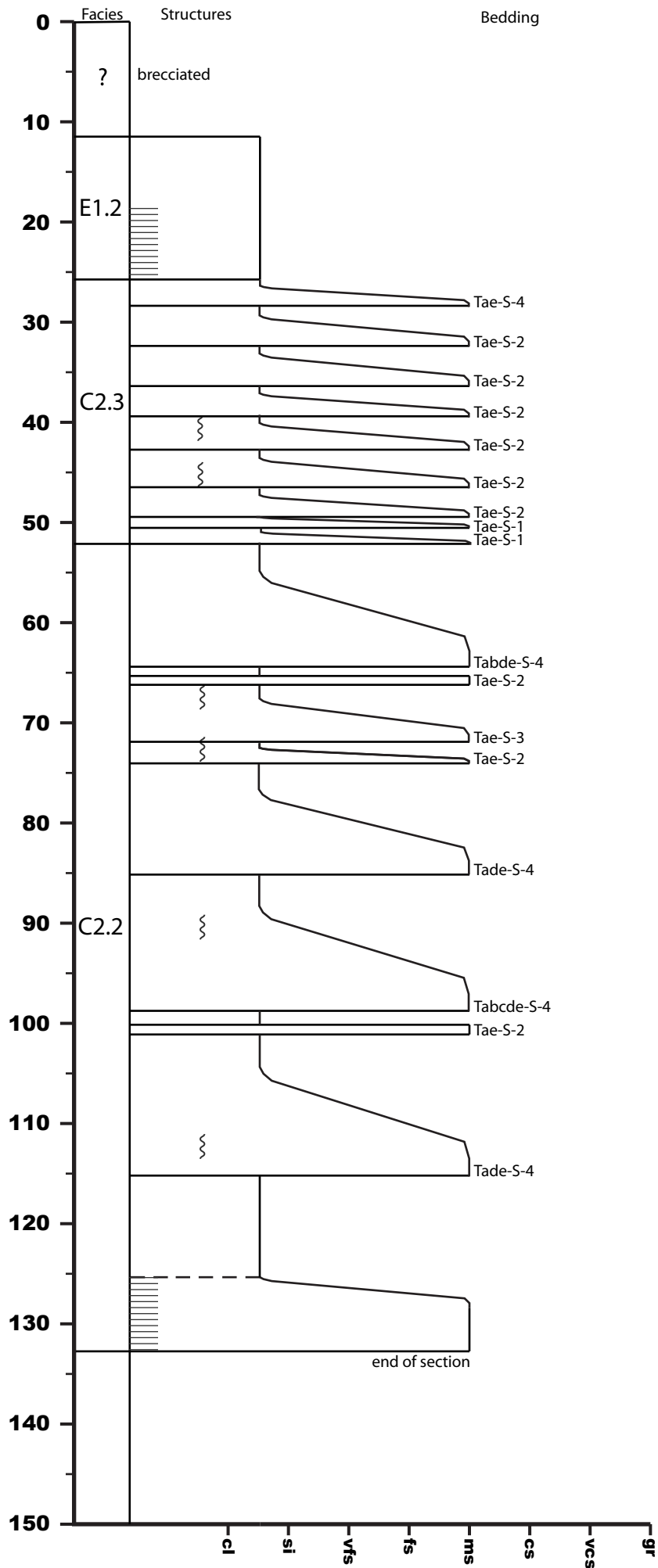

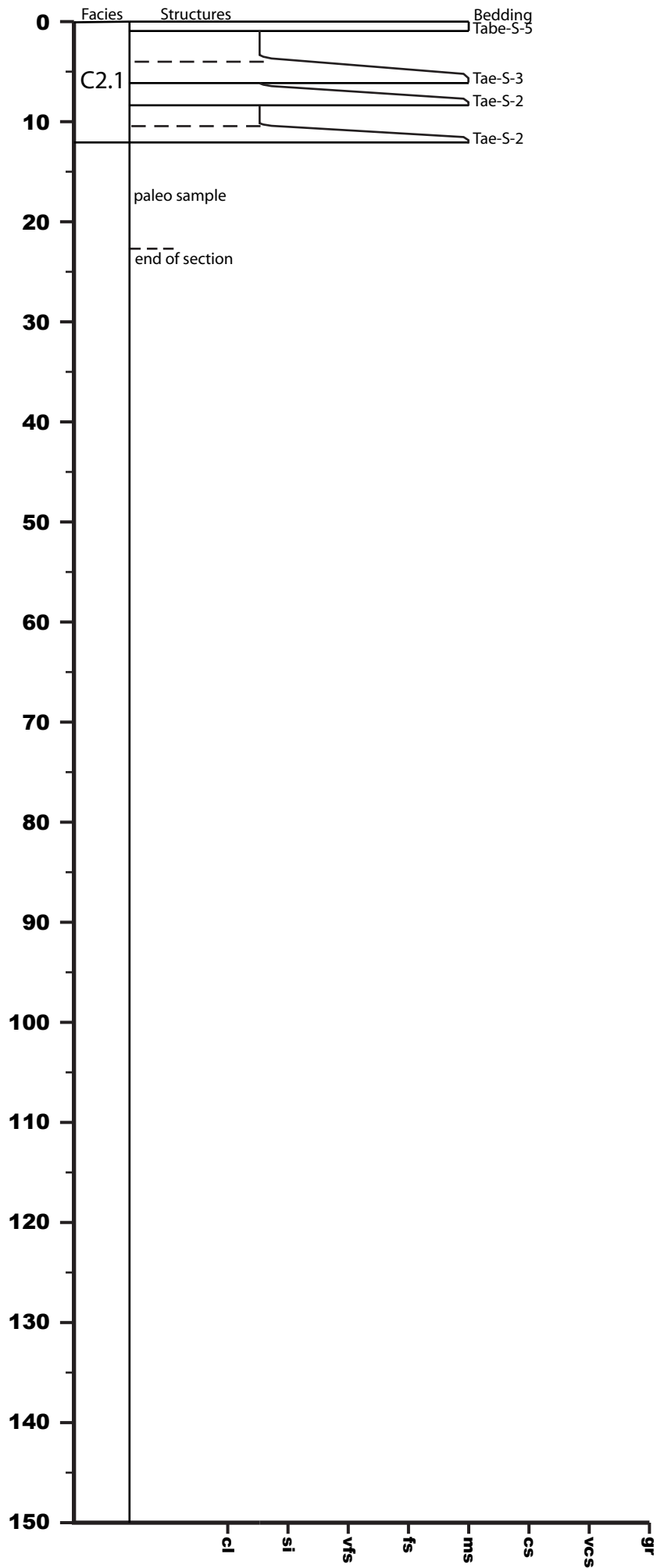

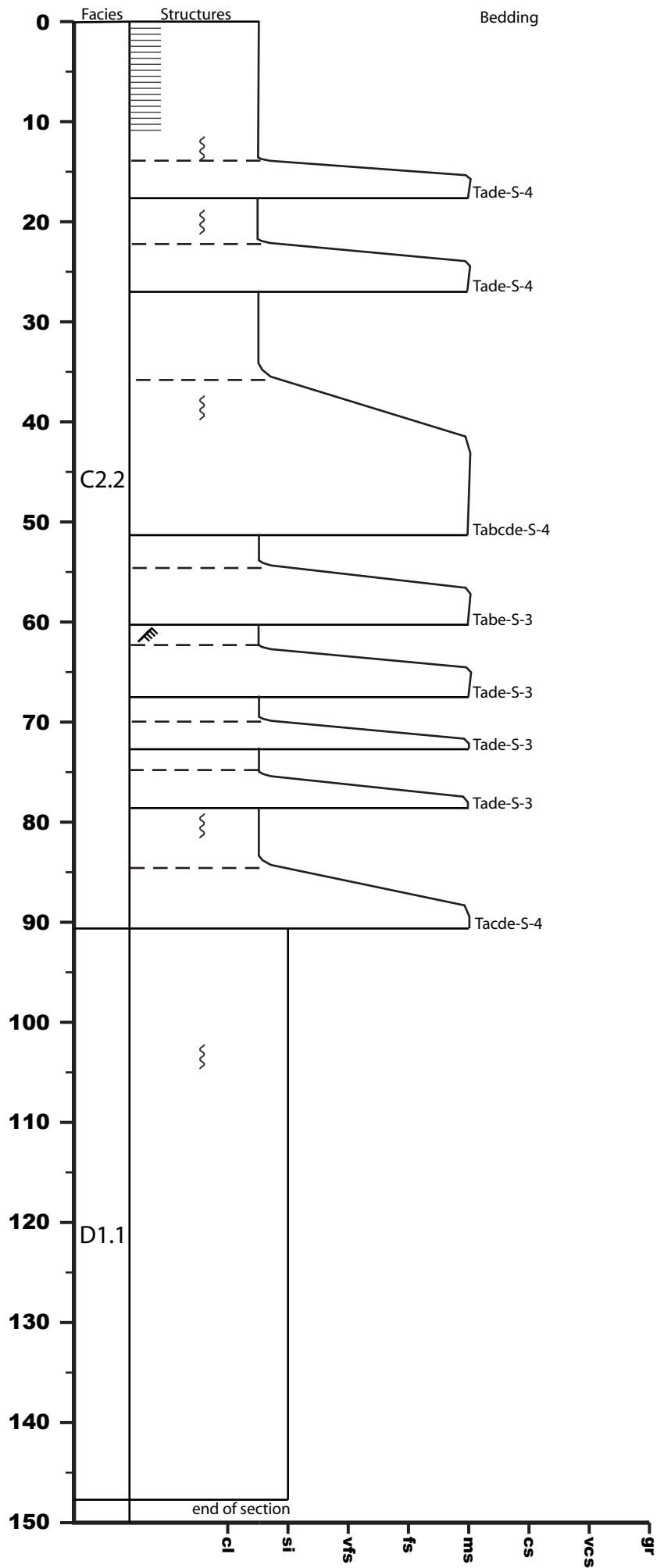

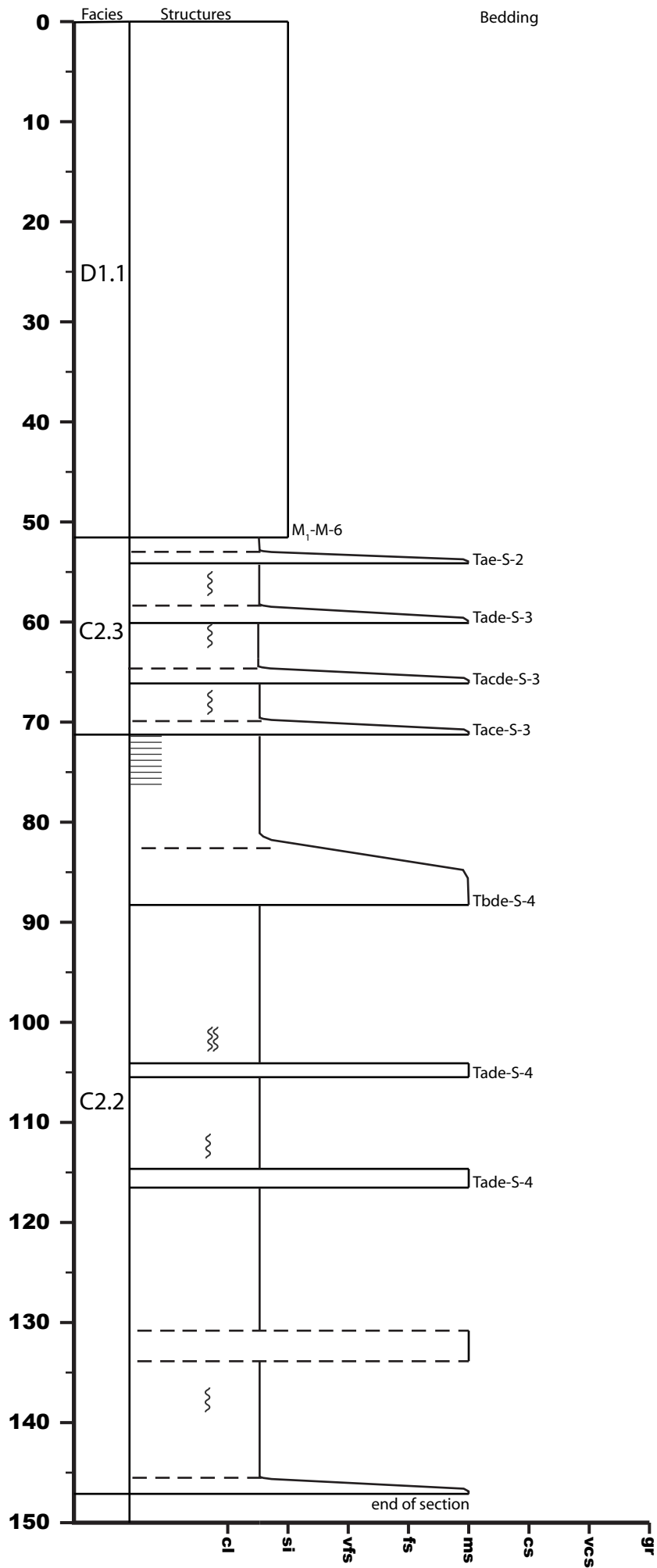

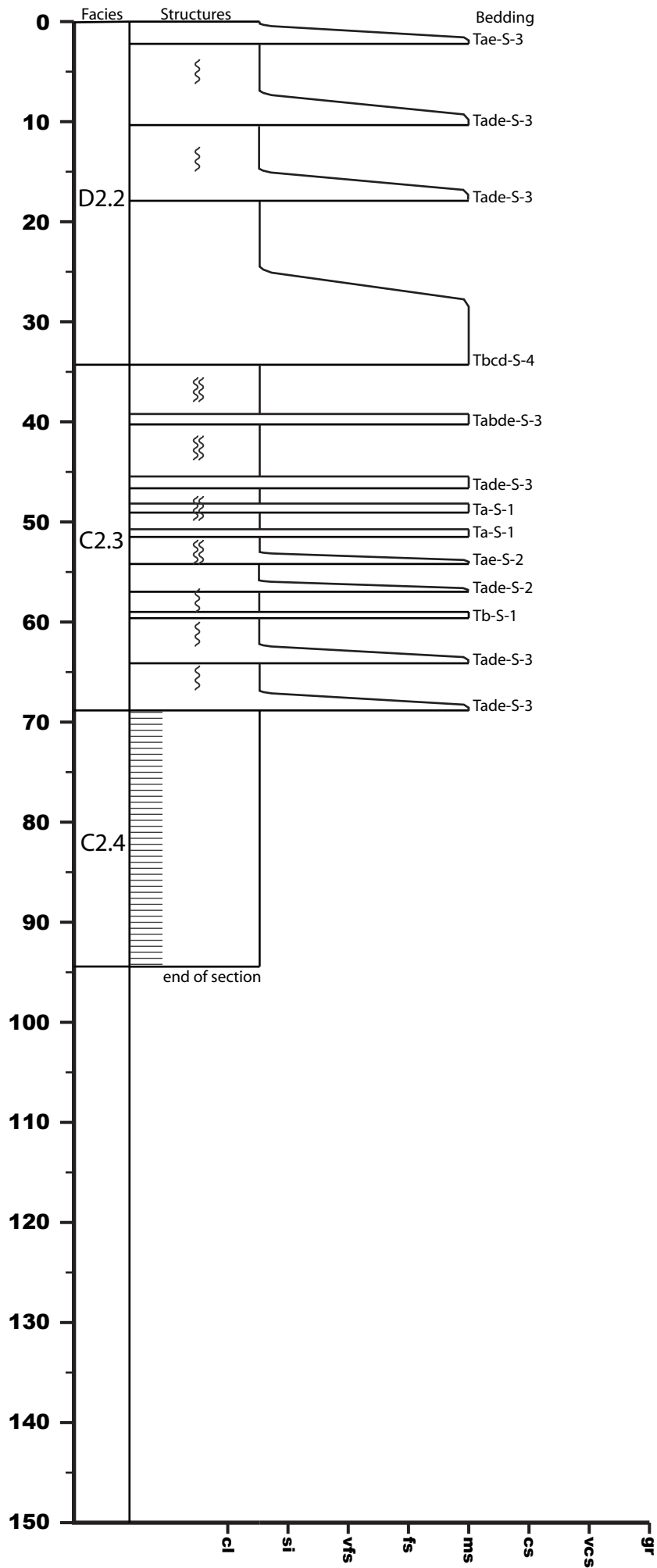

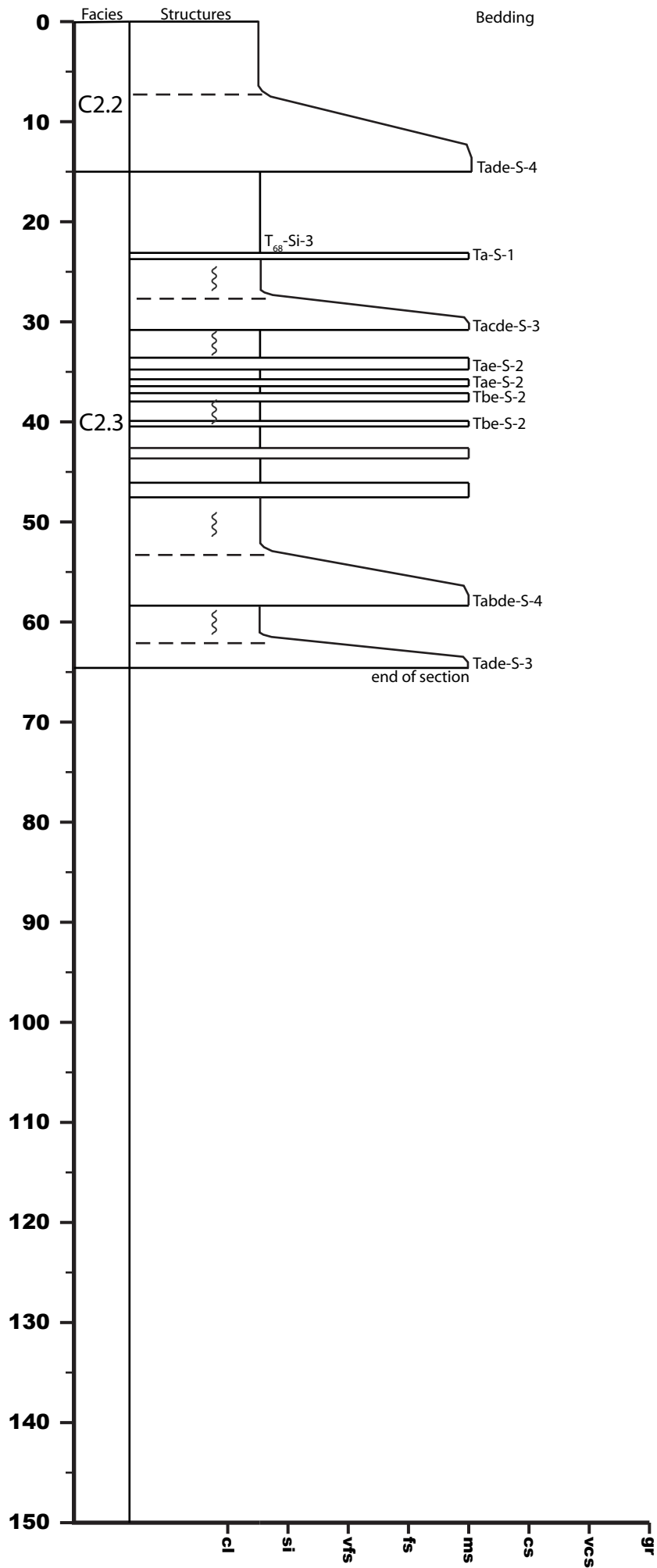



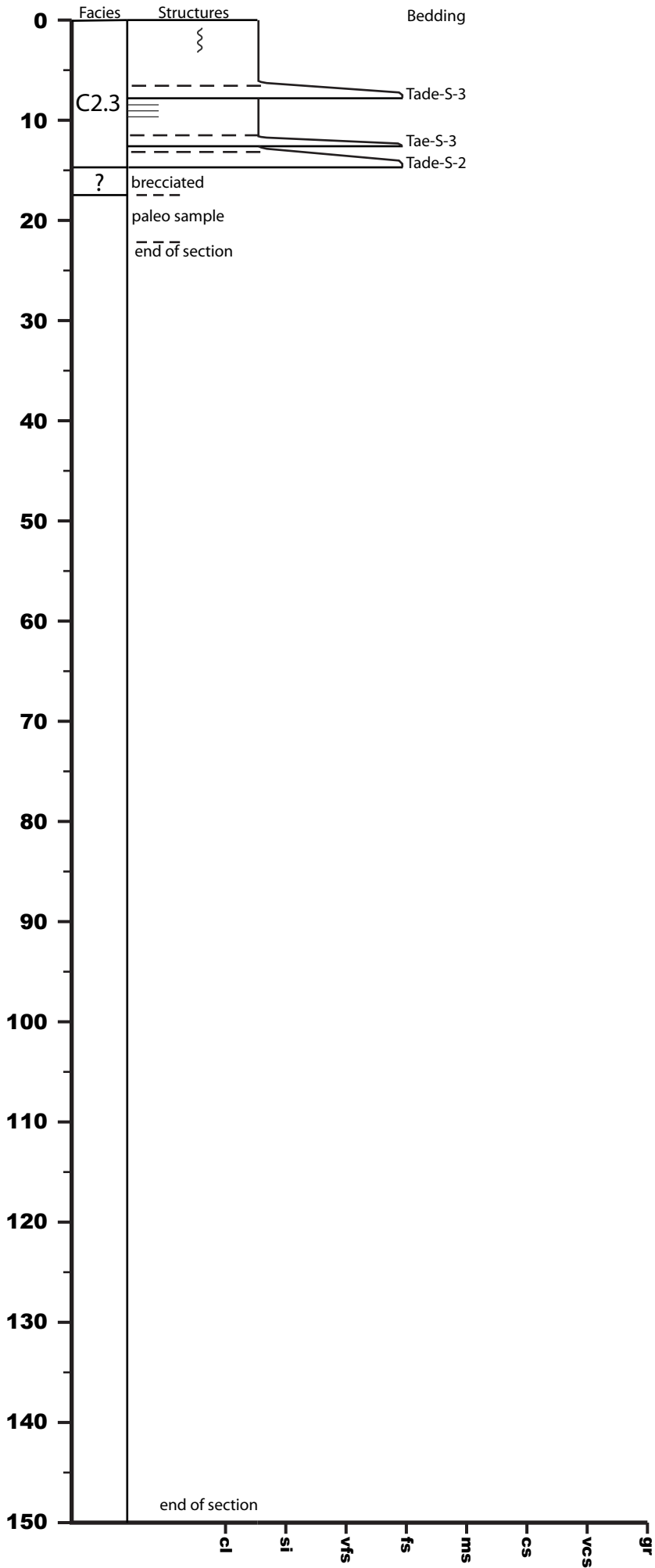

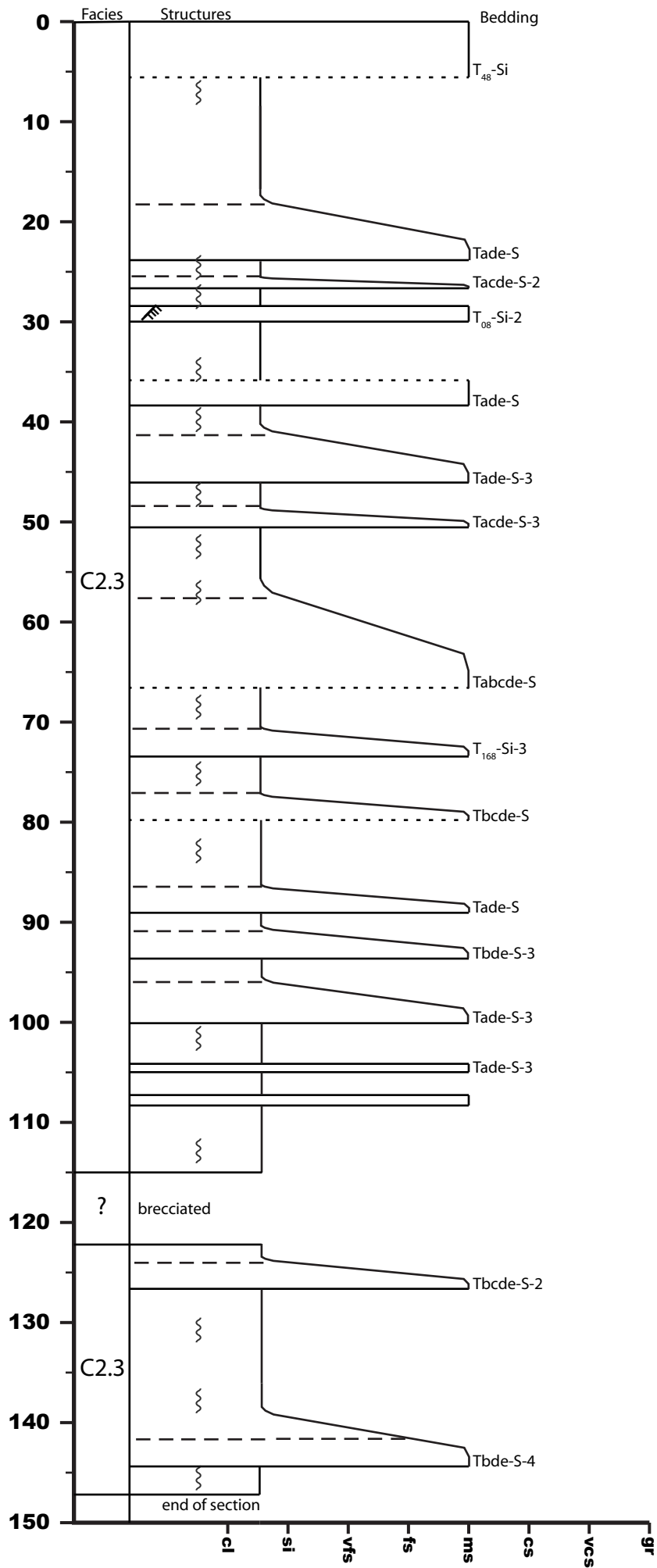

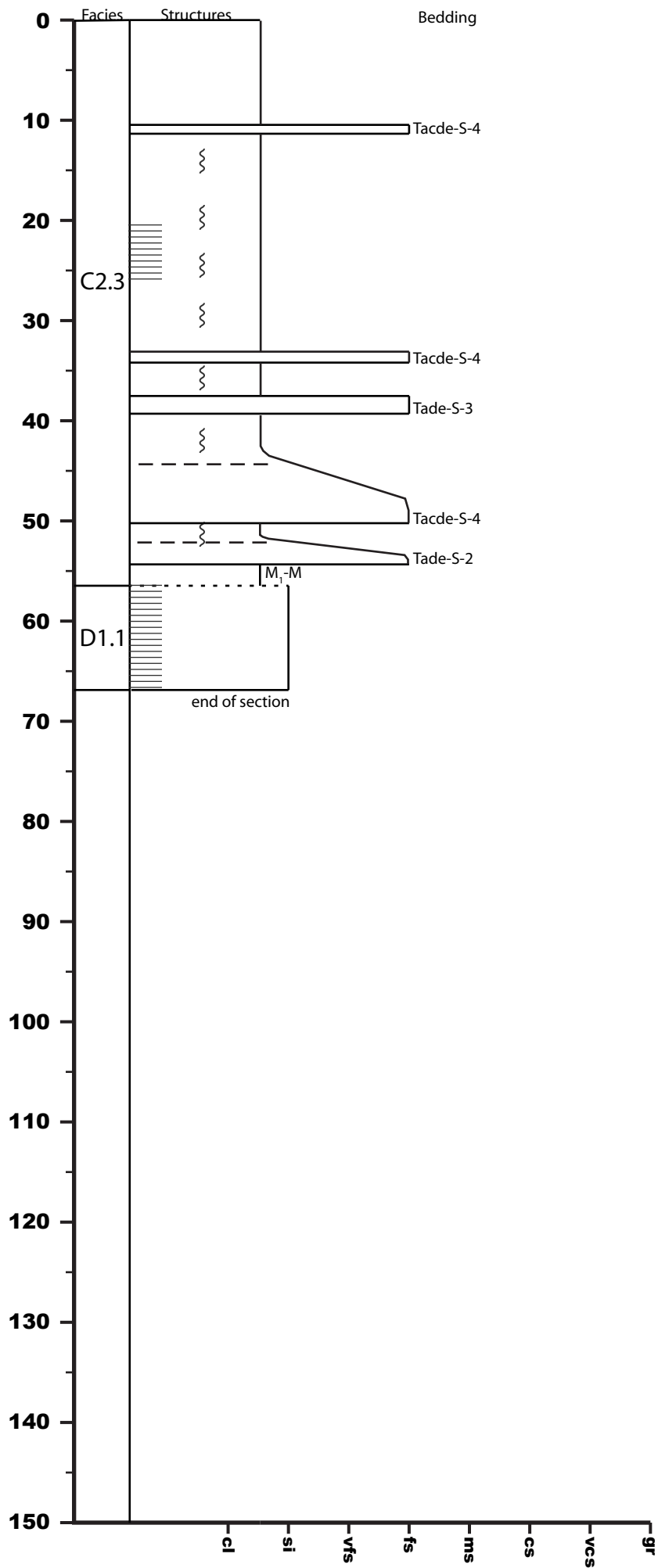

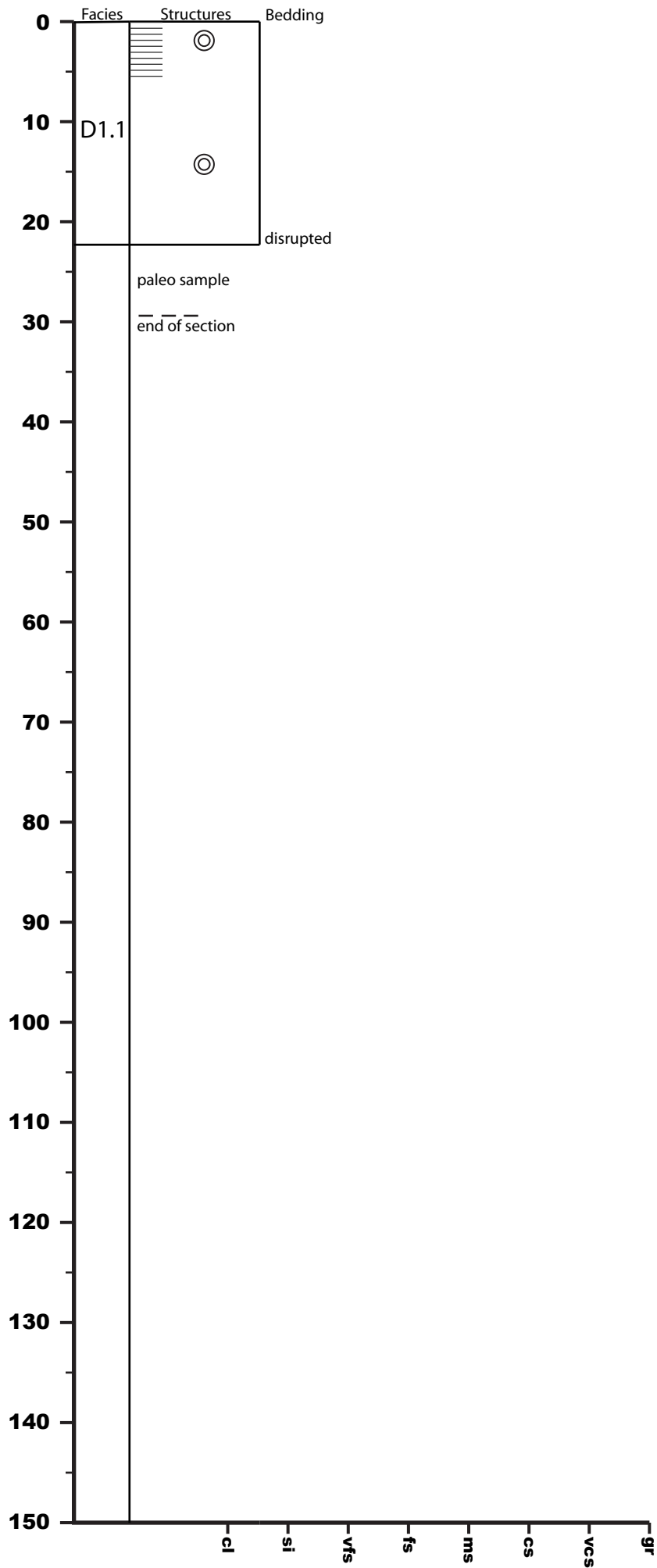

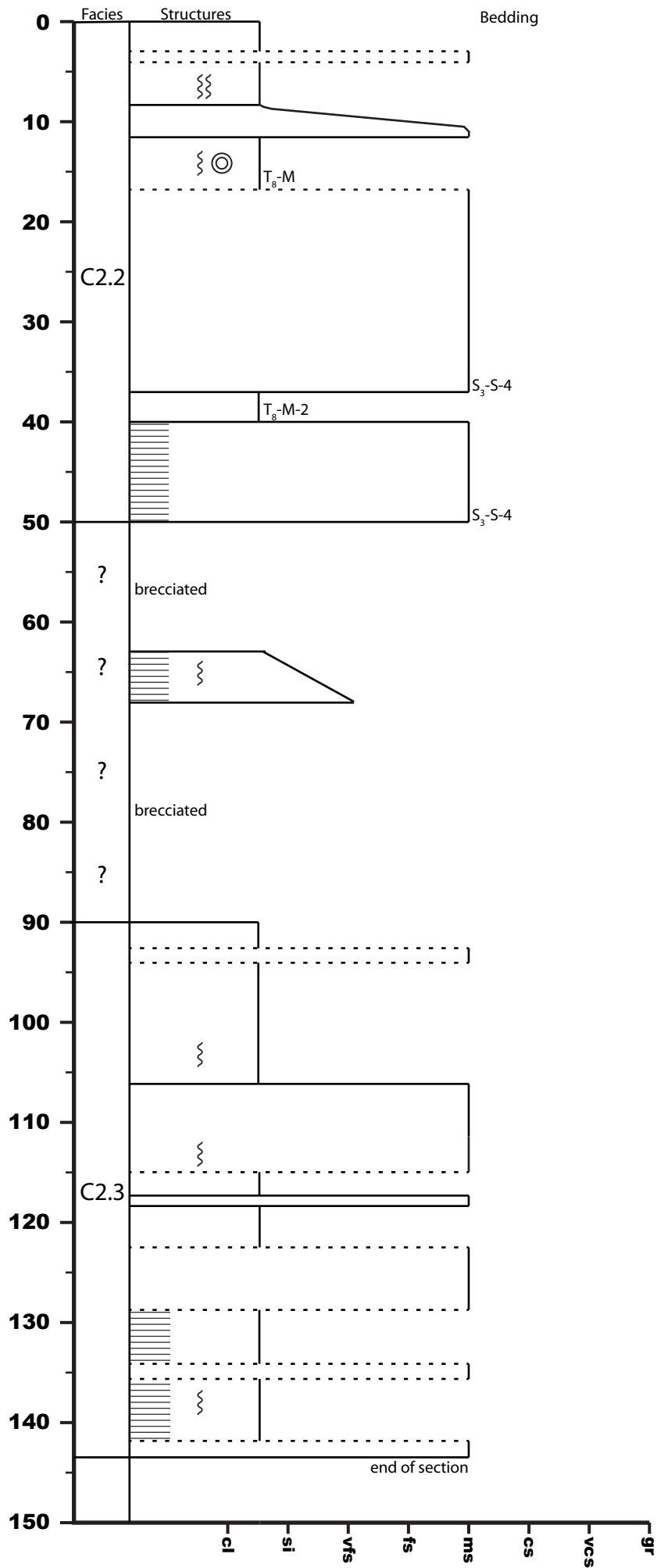

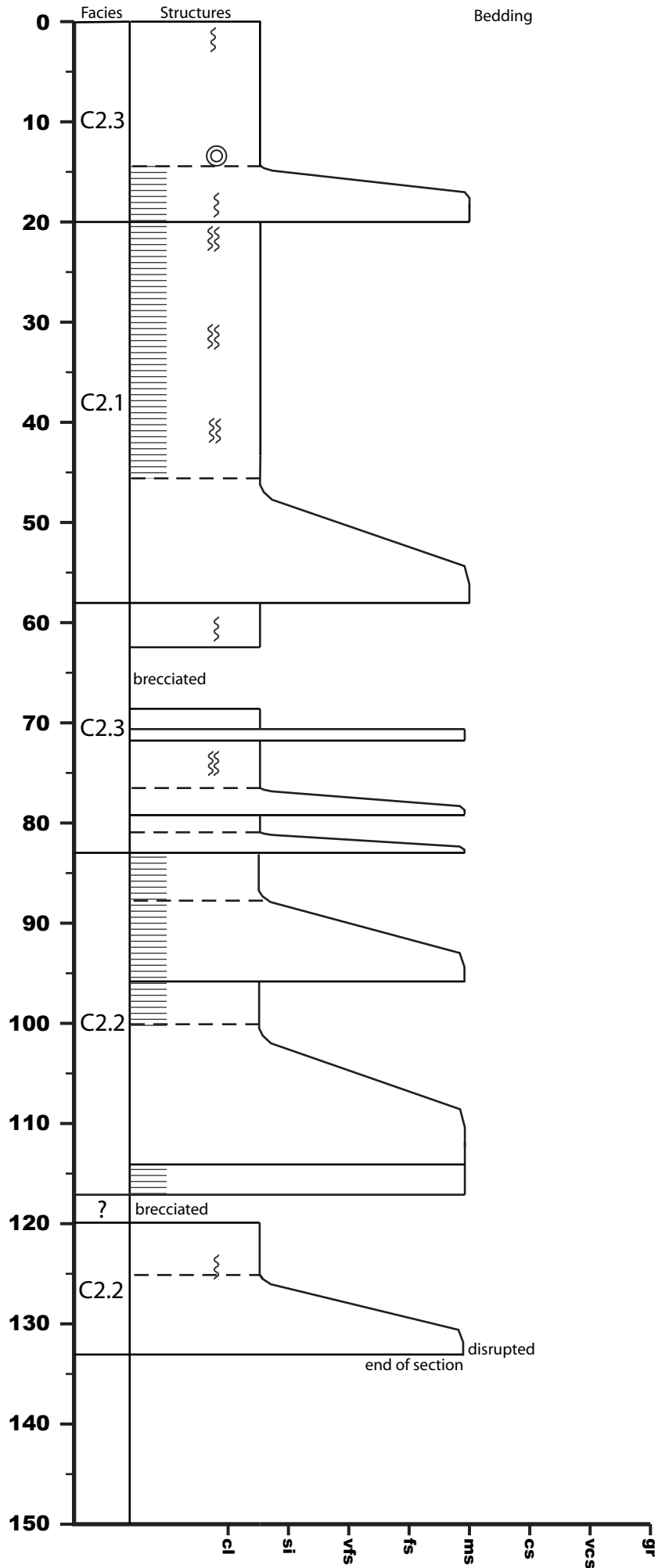

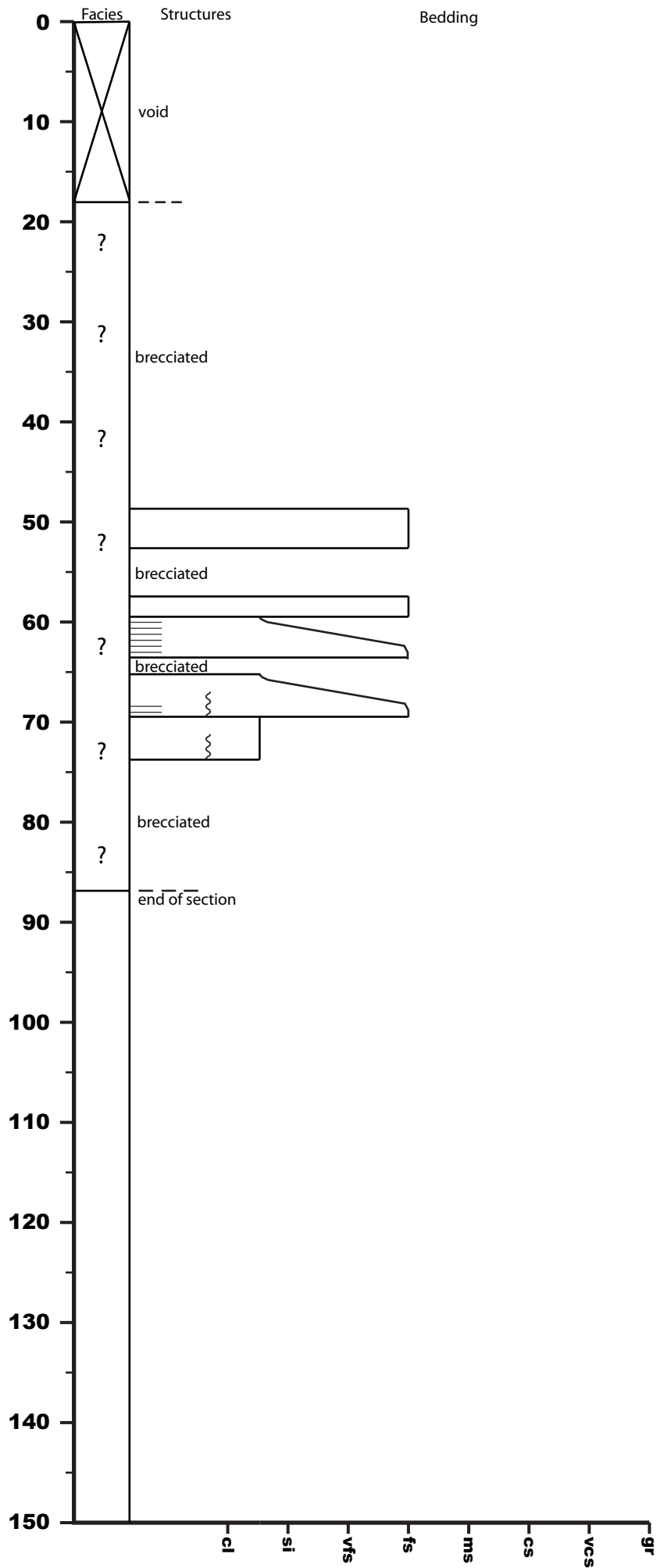

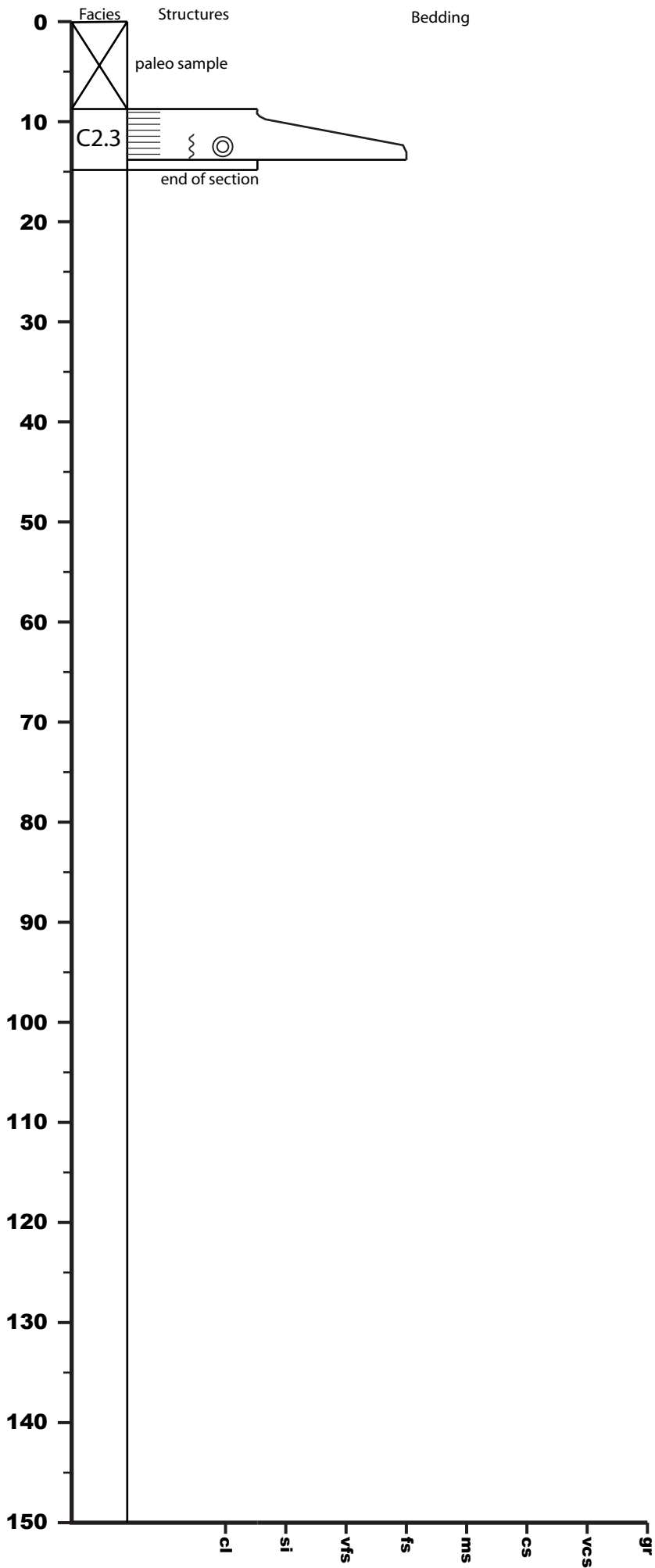



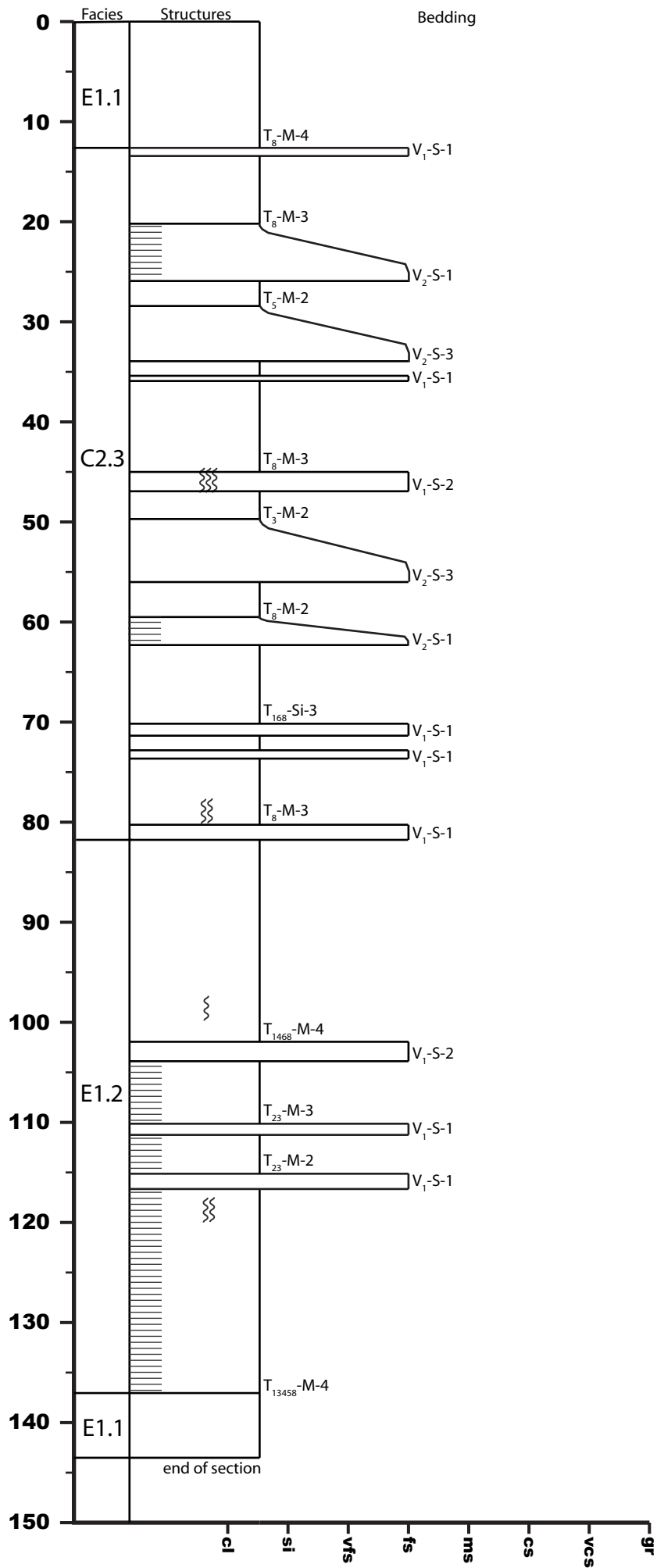

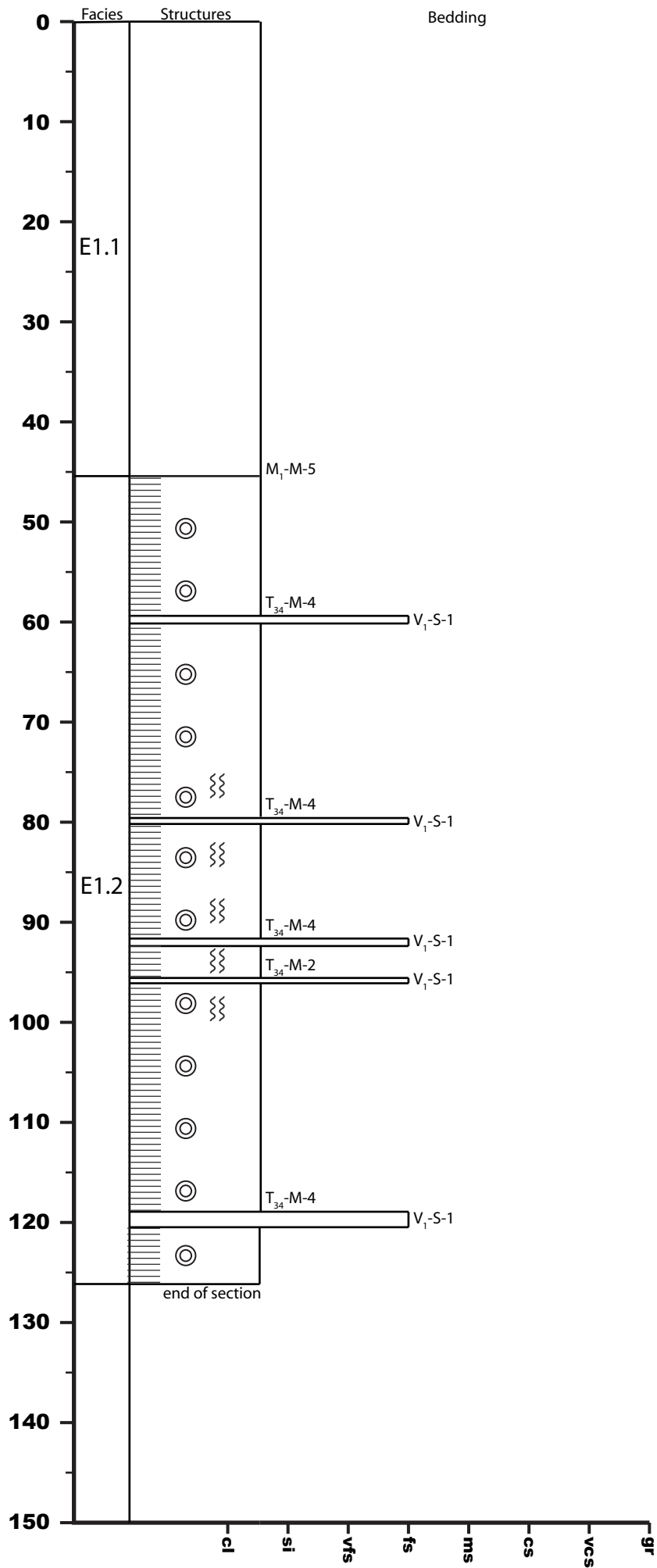

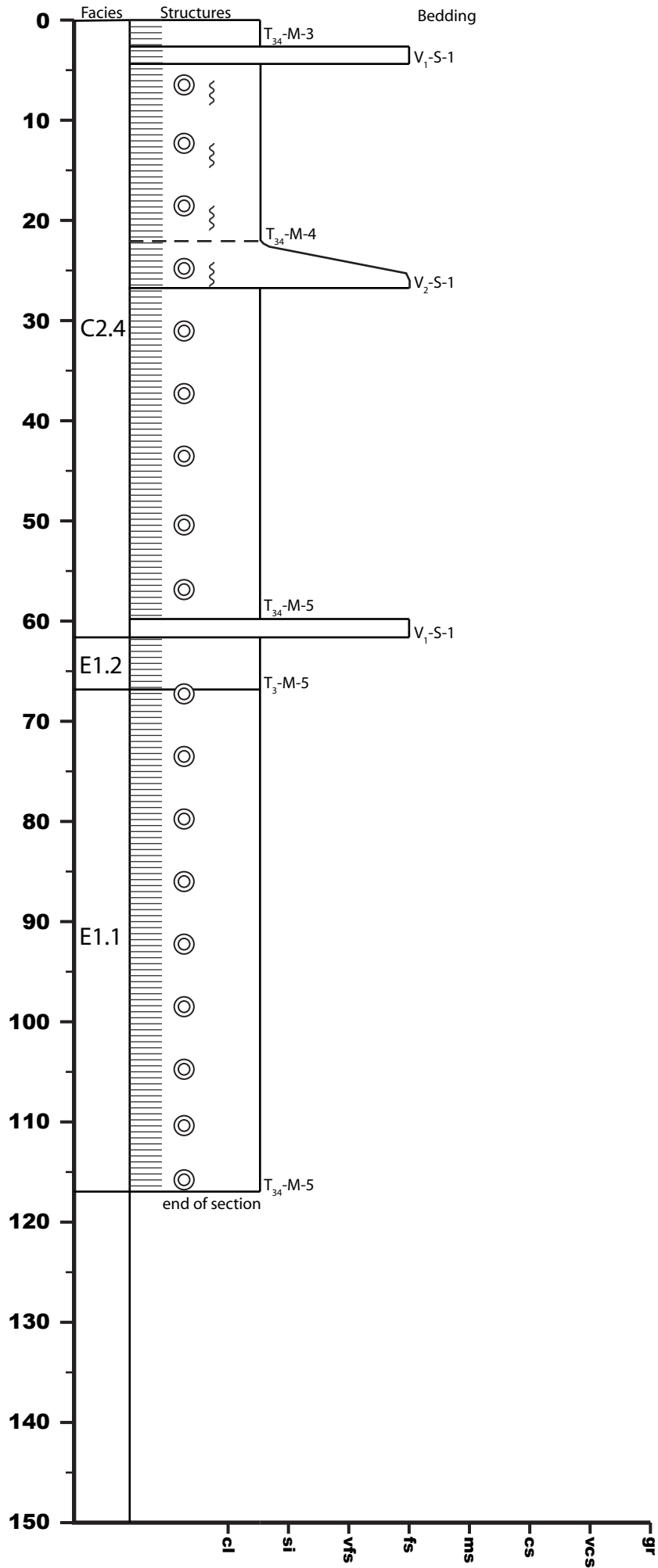

U1438E-55R-CC

1362.47 - 1362.6 mbsf

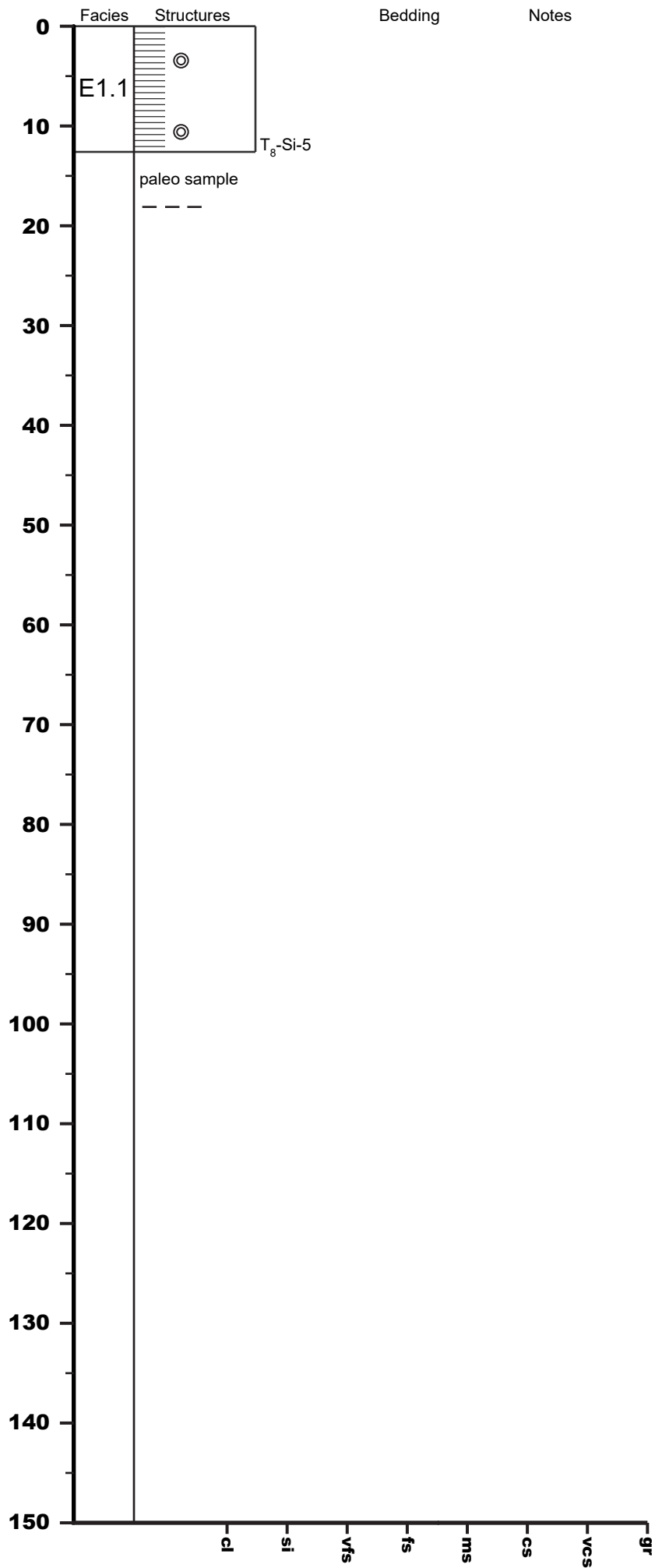

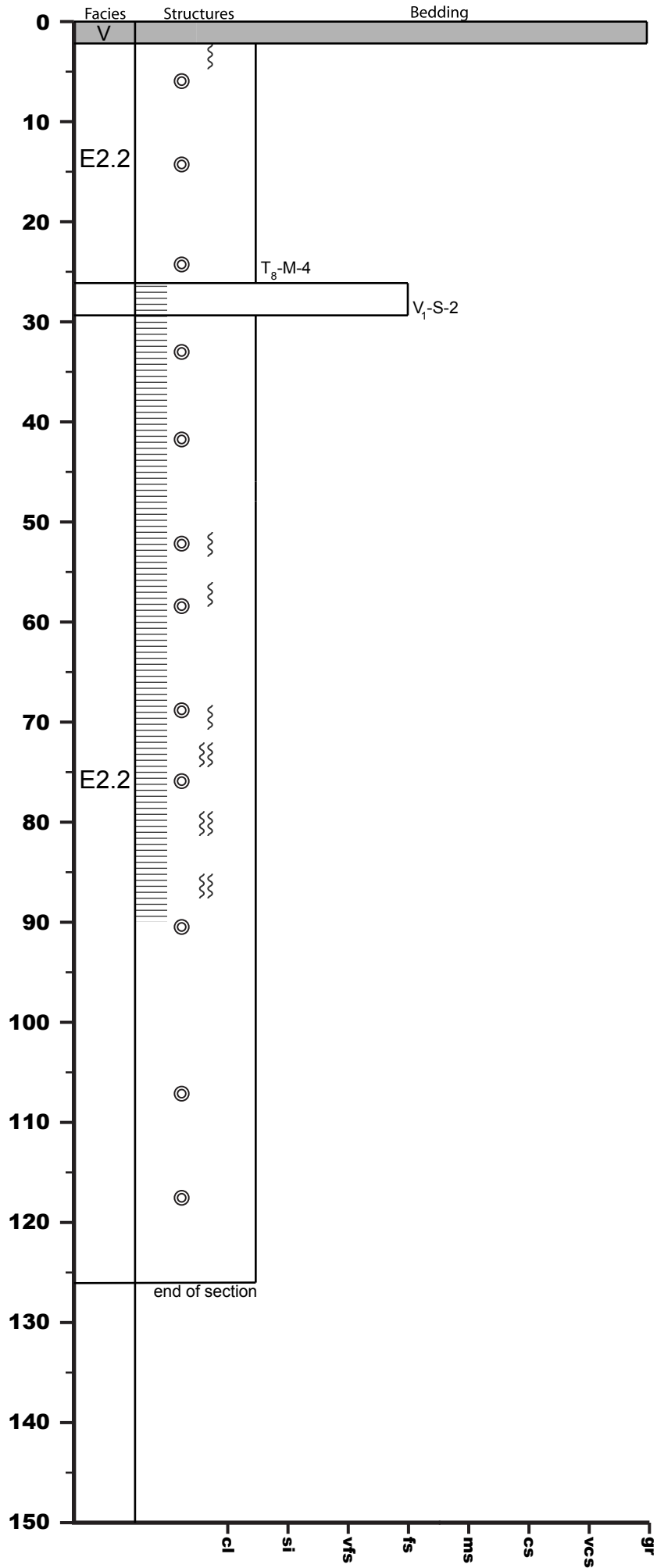

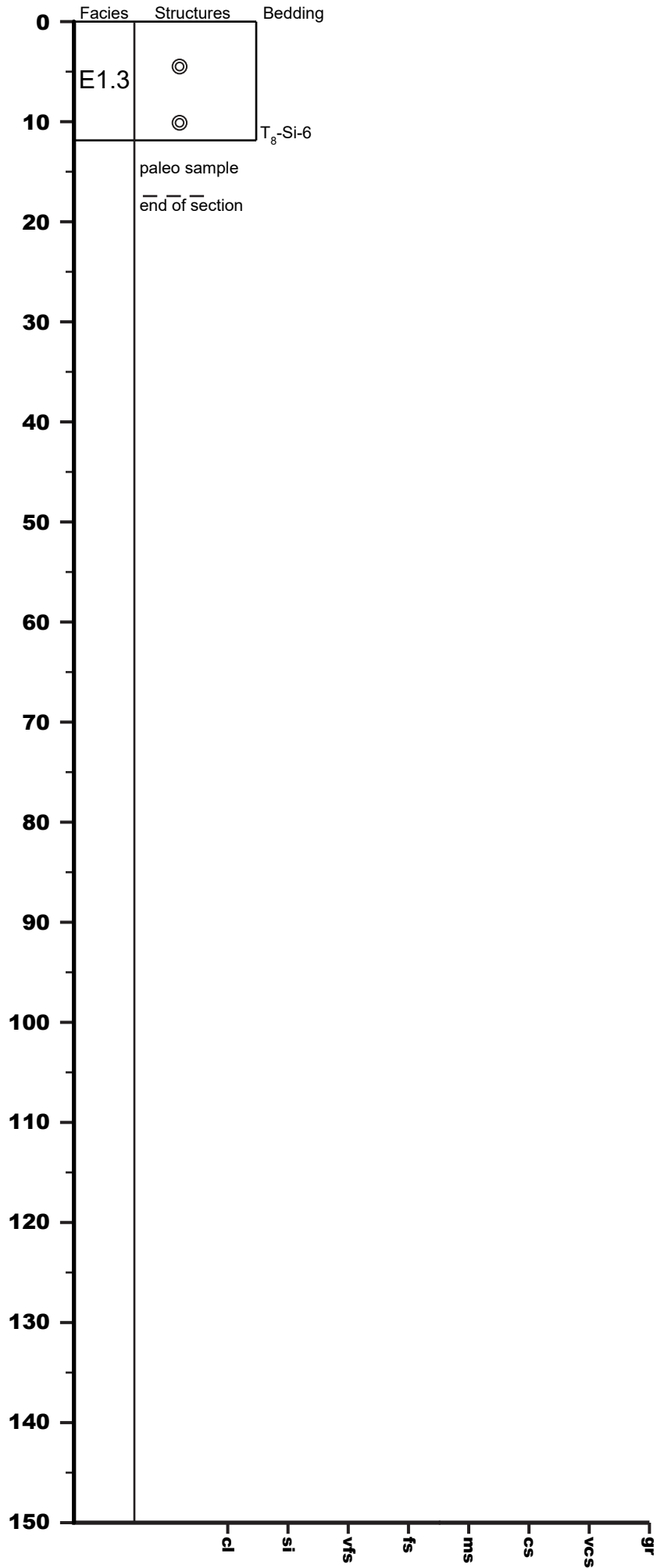

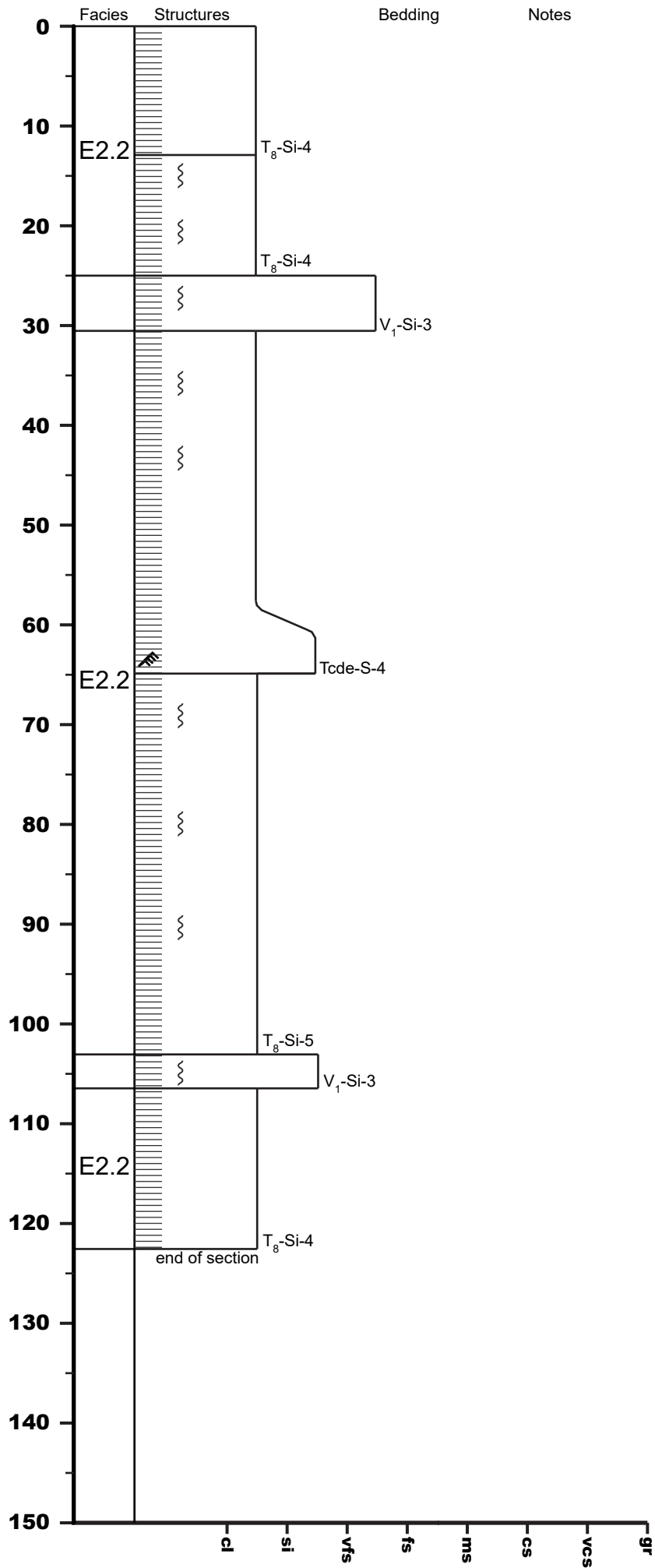

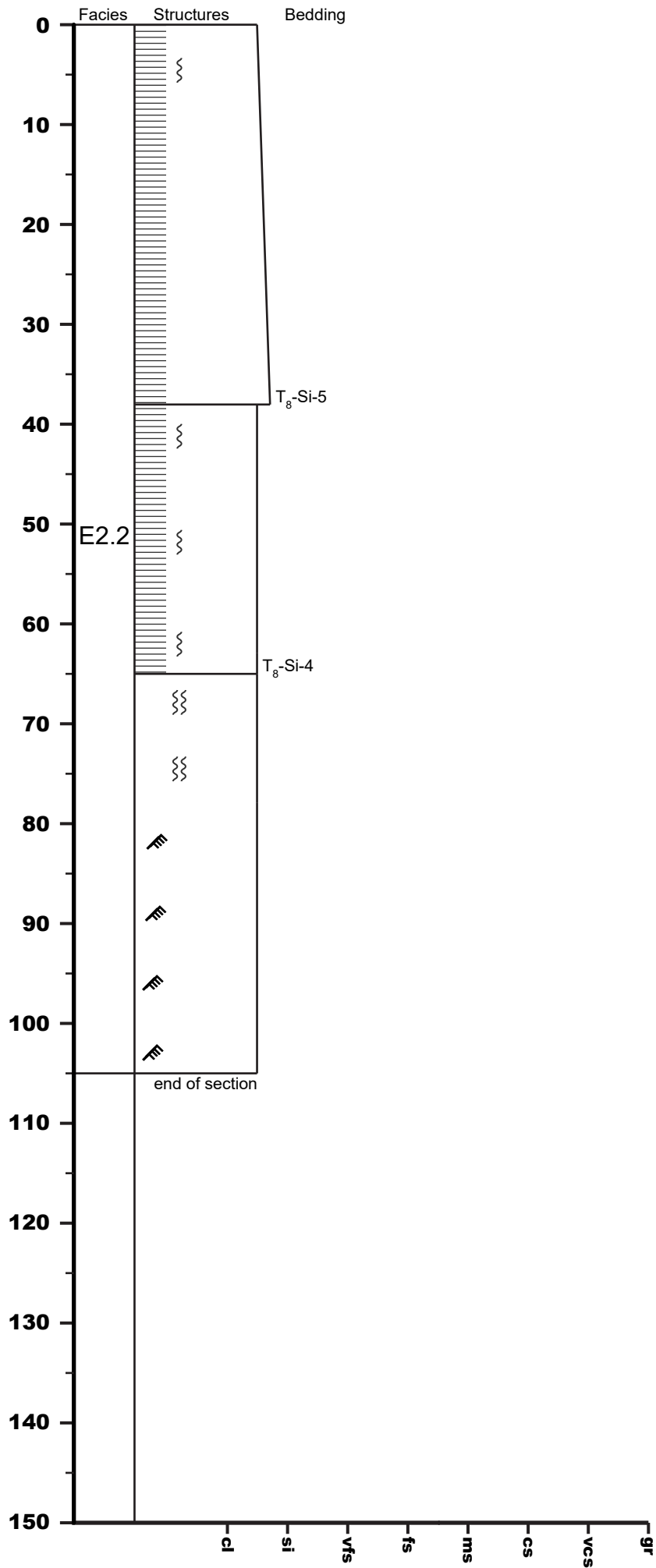



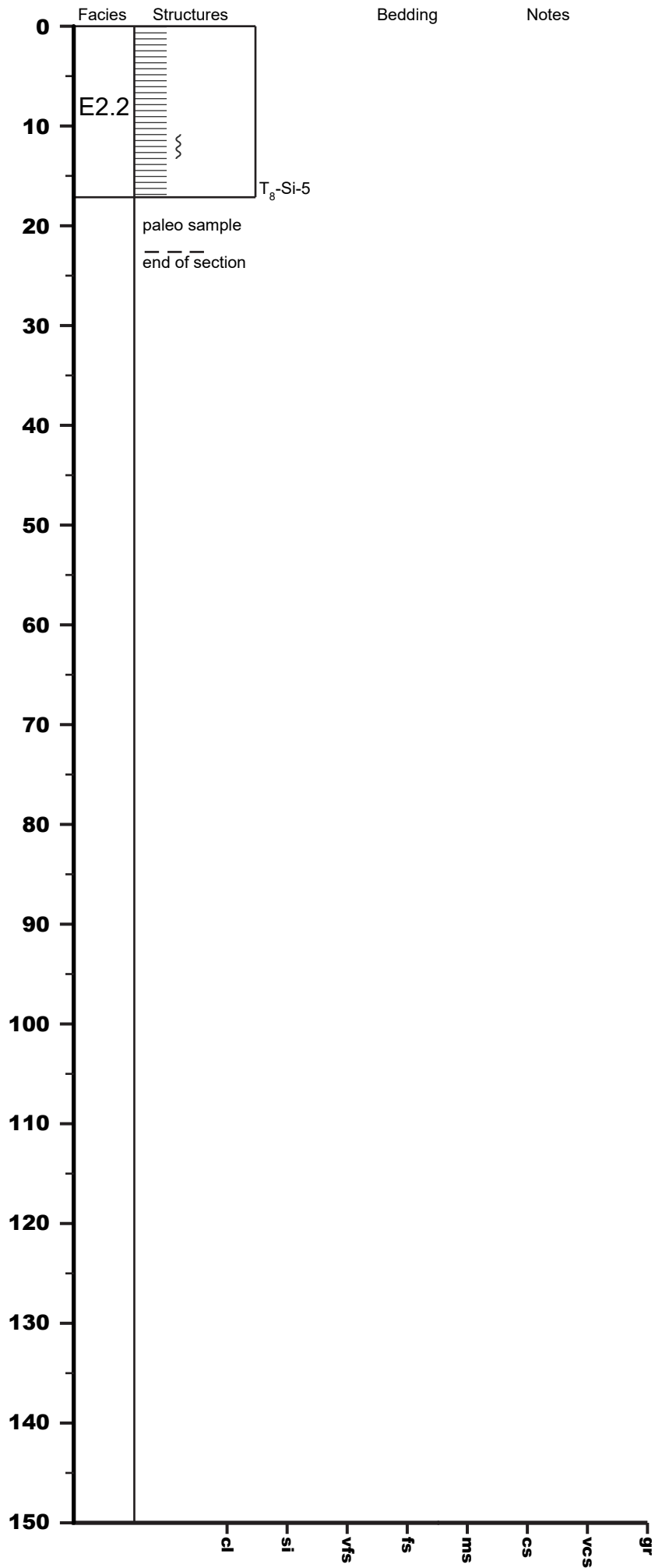

U1438E-58R-1

1386.2 - 1387.08 mbsf

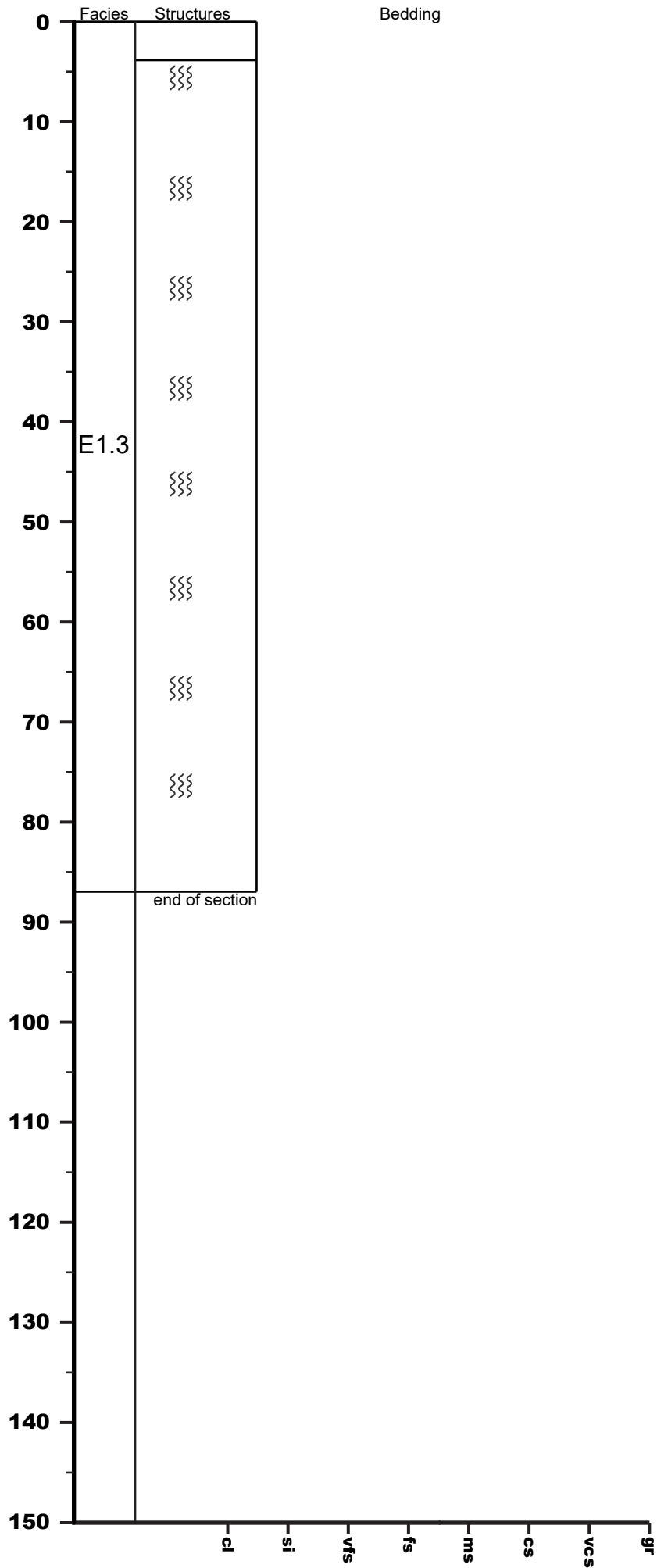

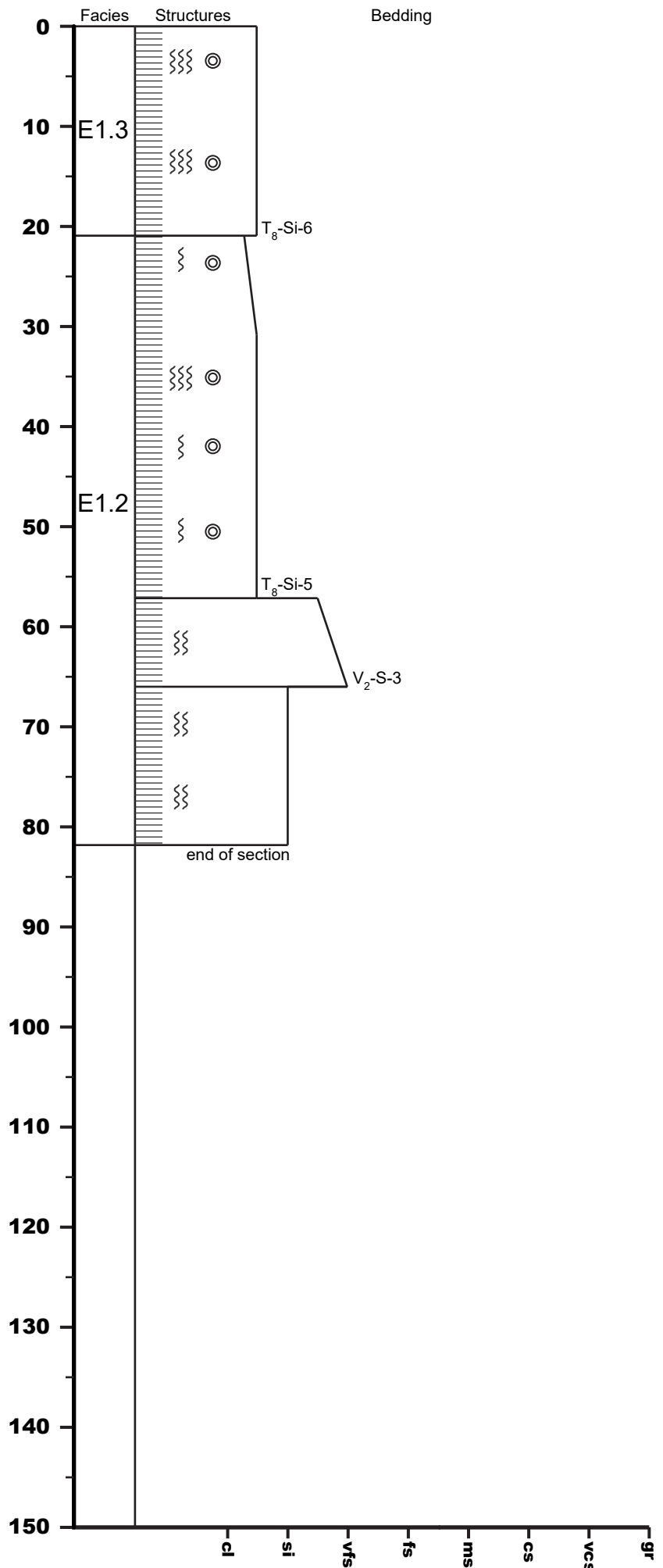

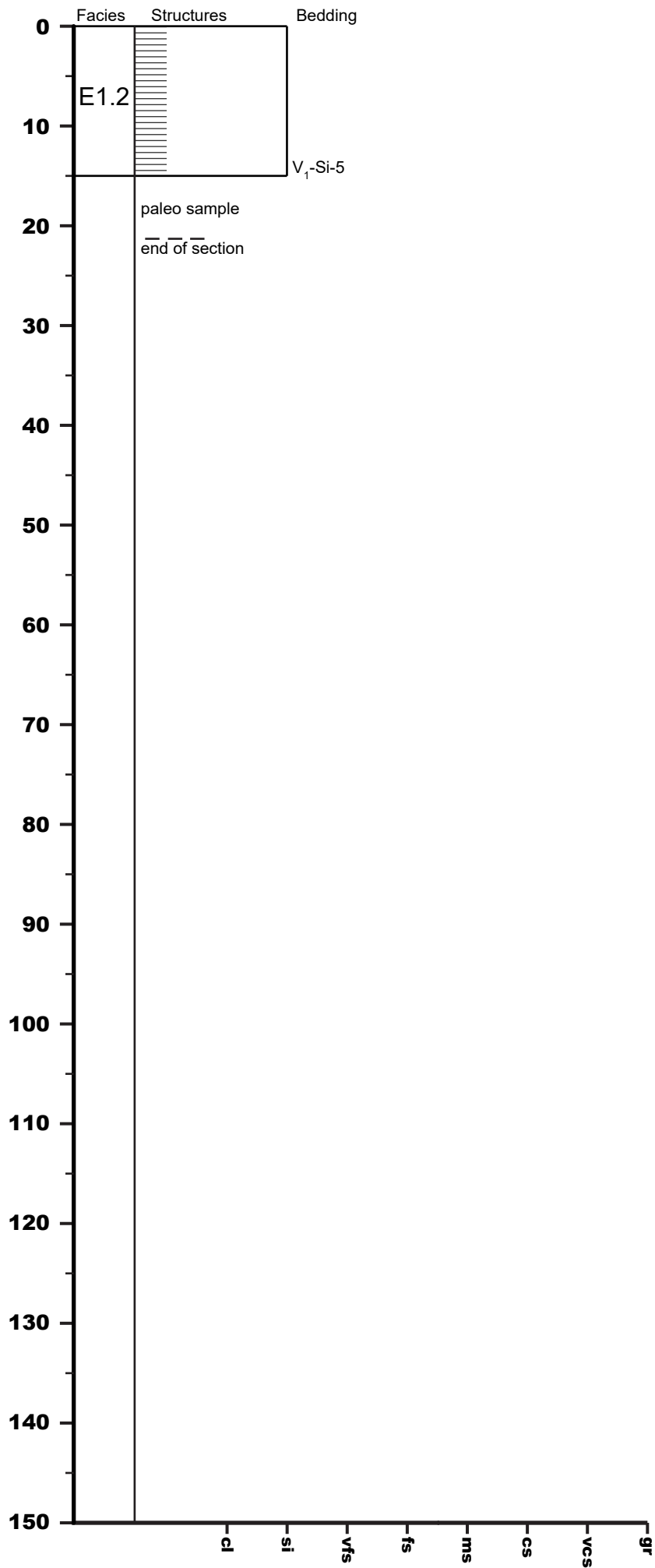

U1438E-59R-1

1395.7 - 1397.06 mbsf

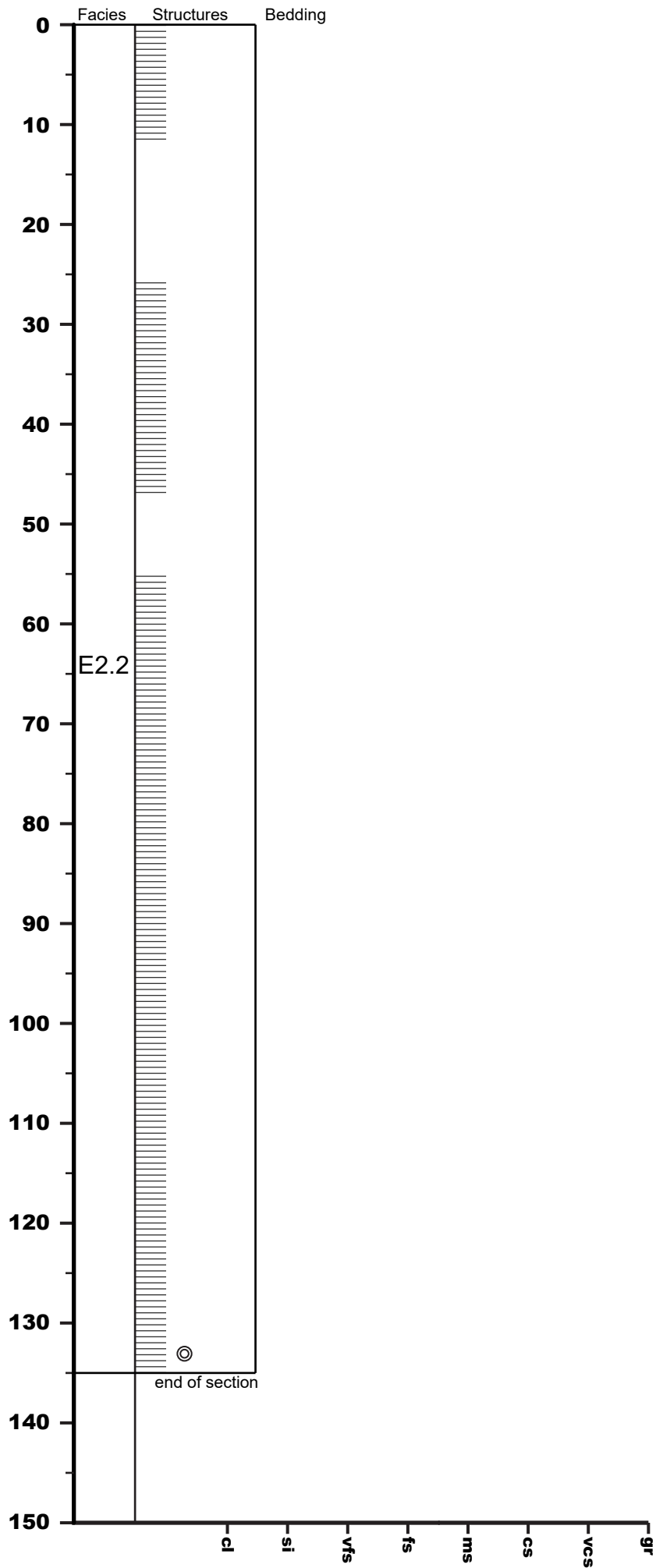

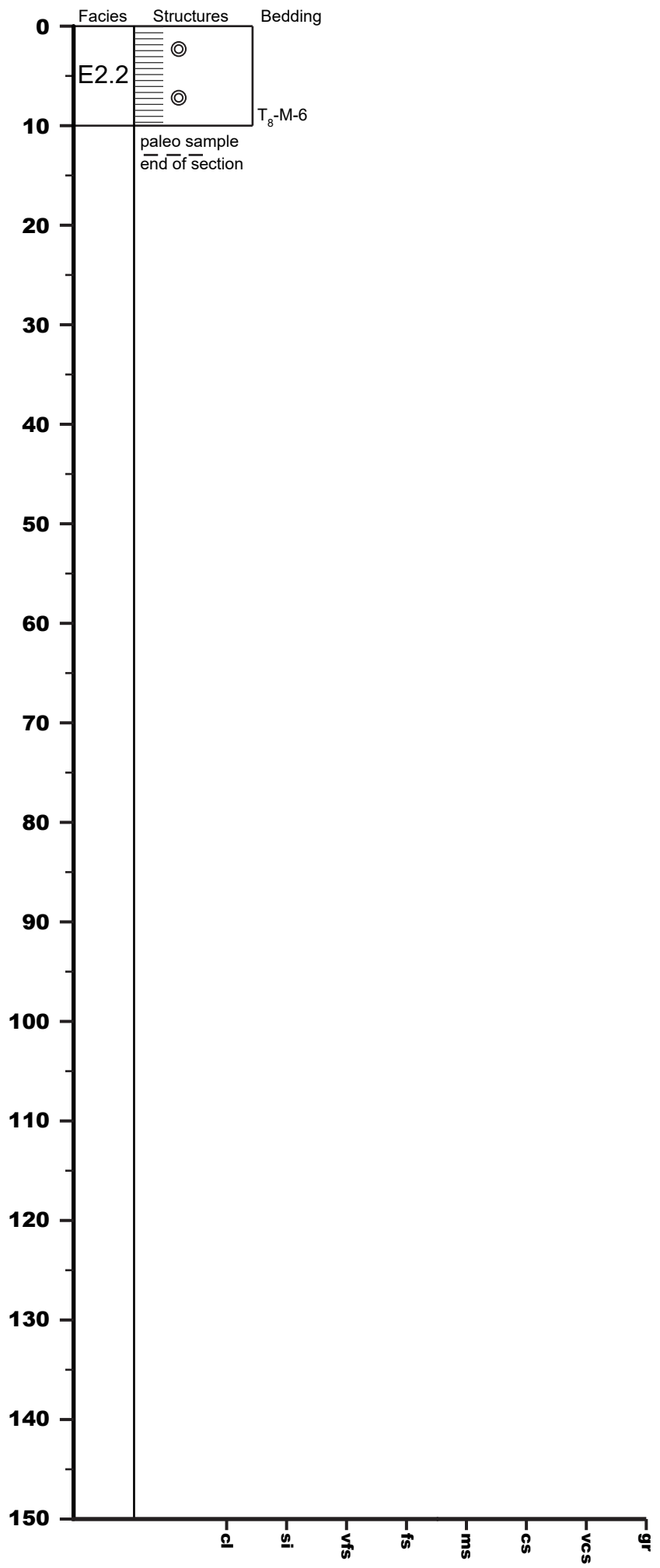

U1438E-60R-1

1400.3 - 1401.37 mbsf

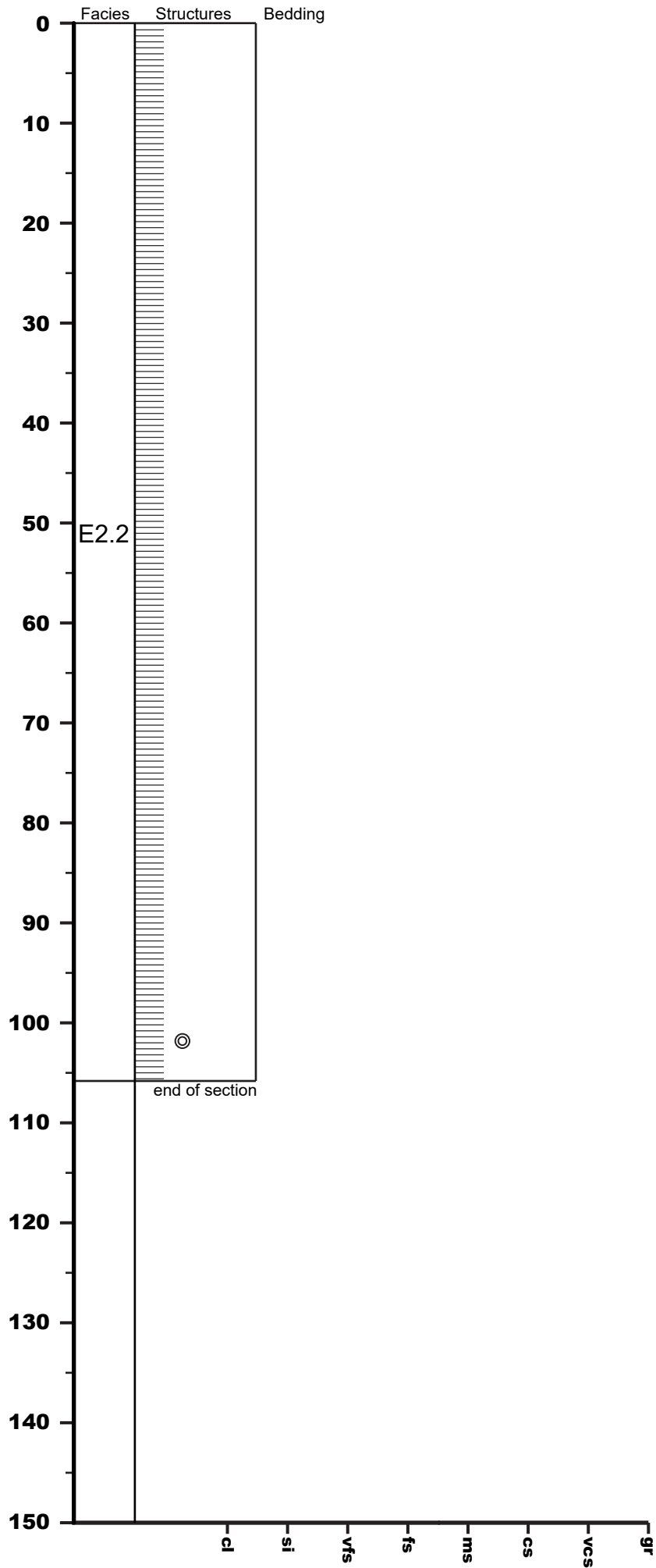

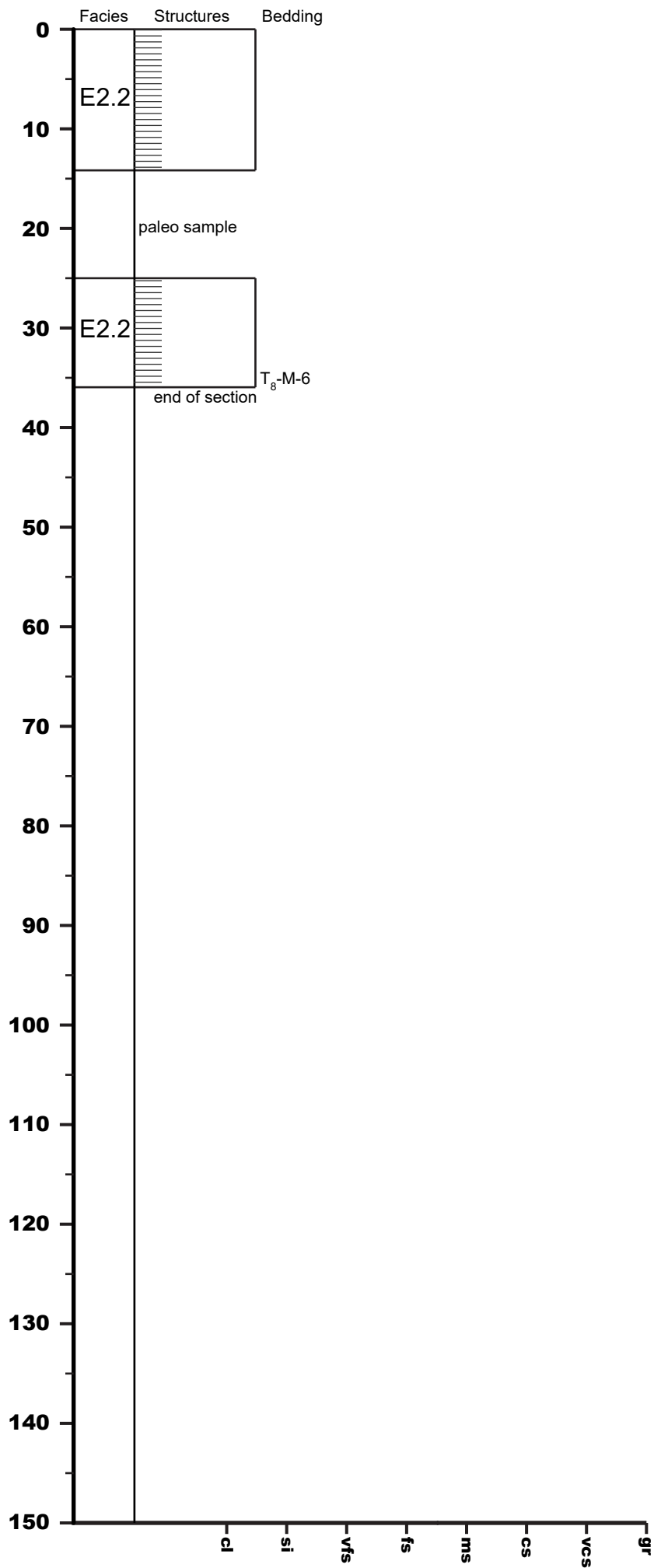



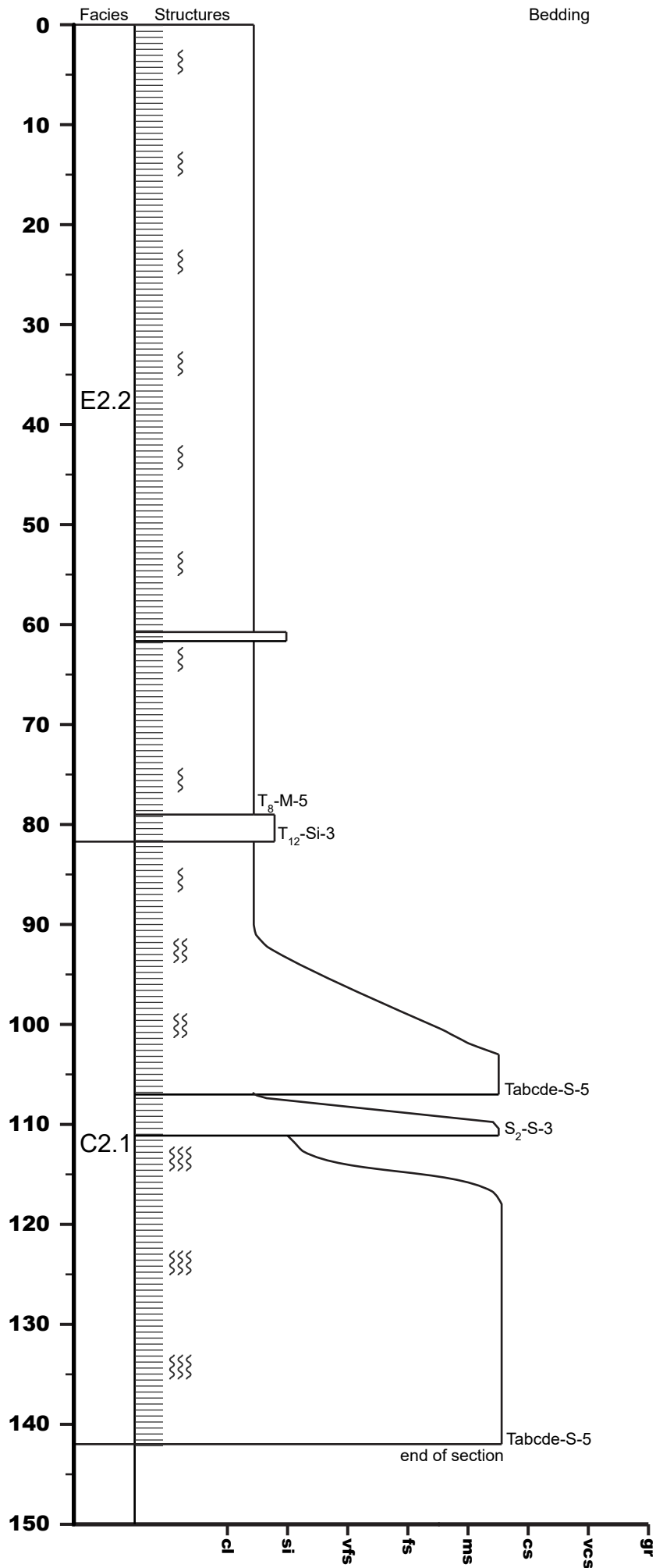

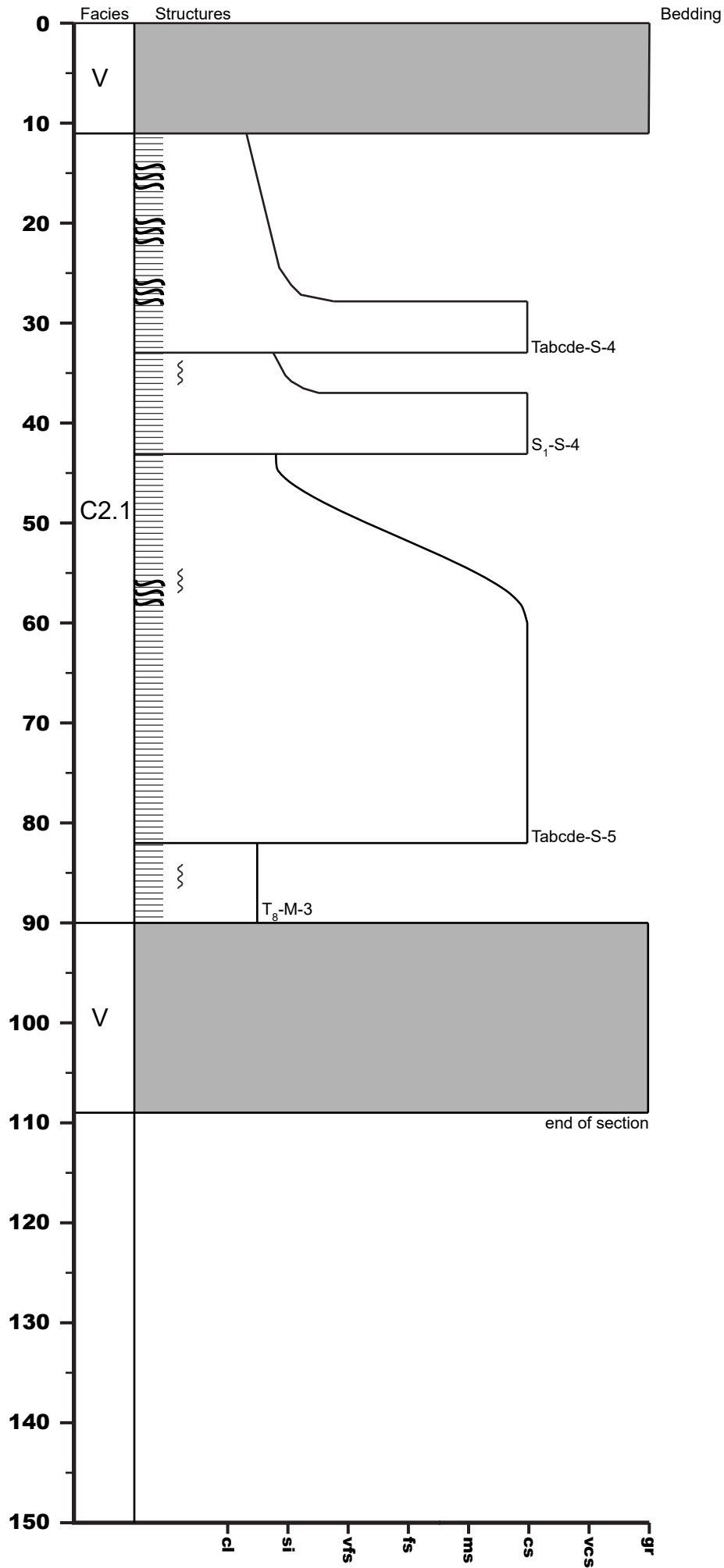

U1438E-61R-3

1407.43 - 1408.12 mbsf

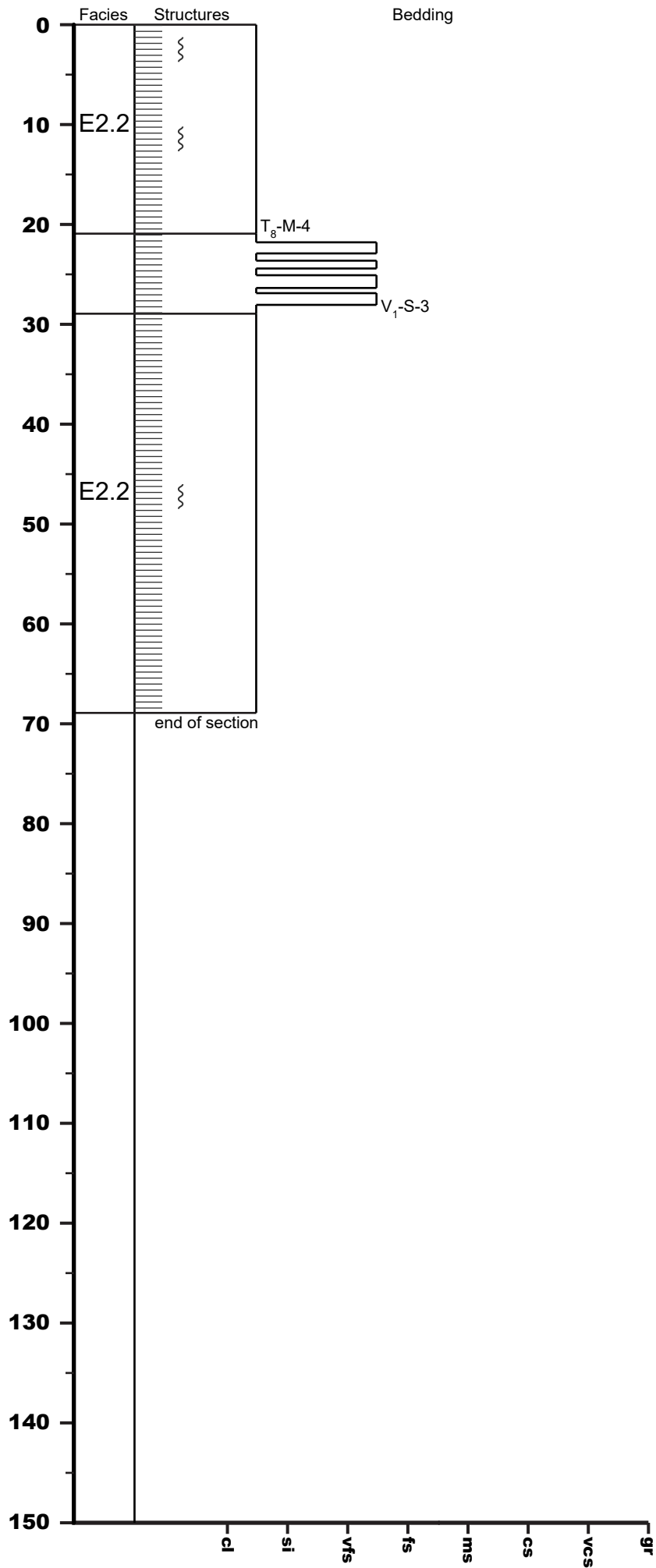

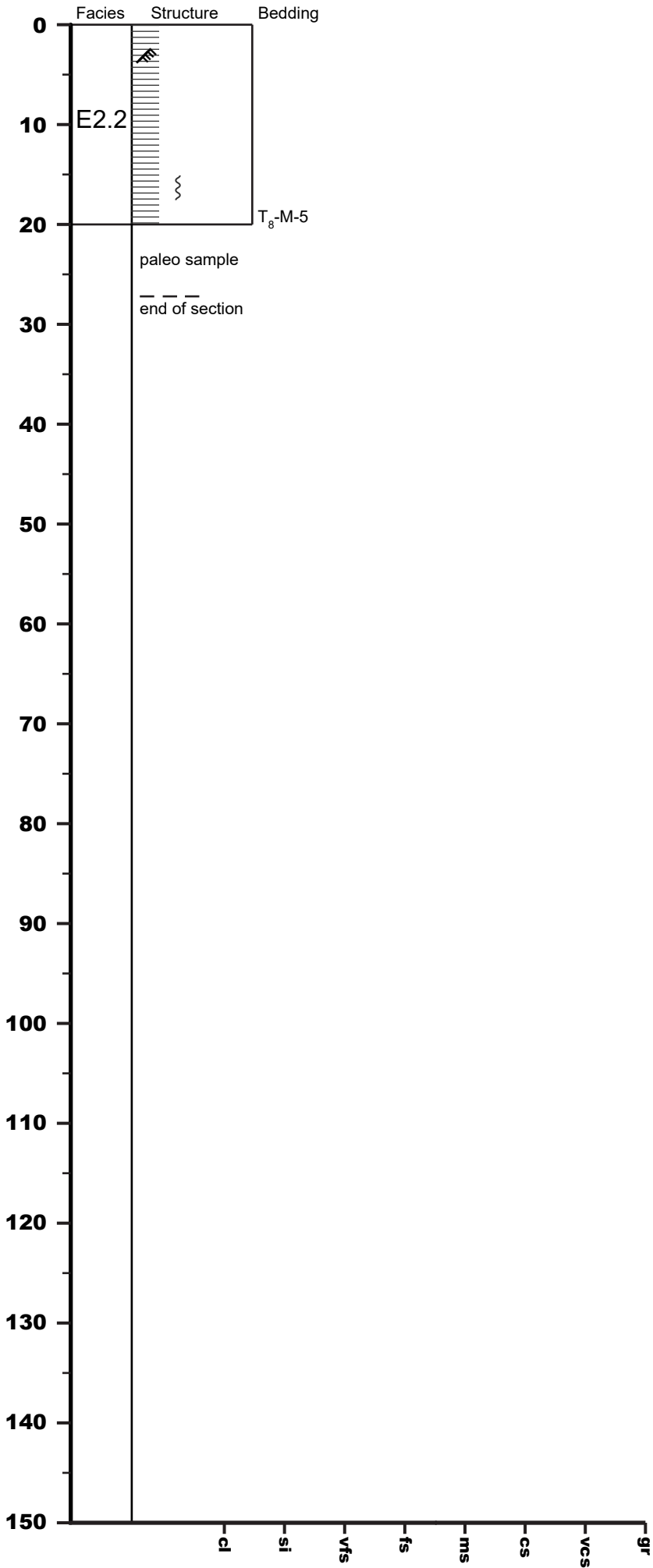

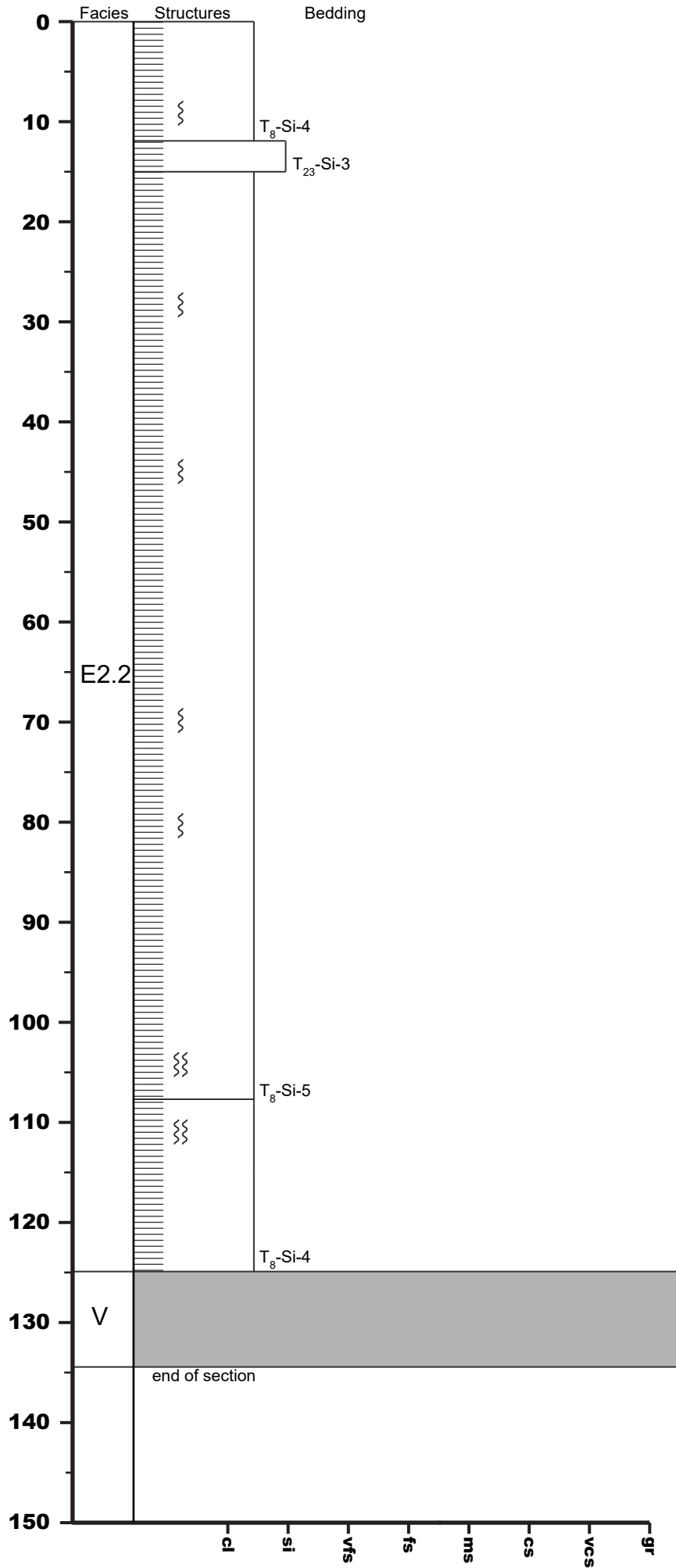

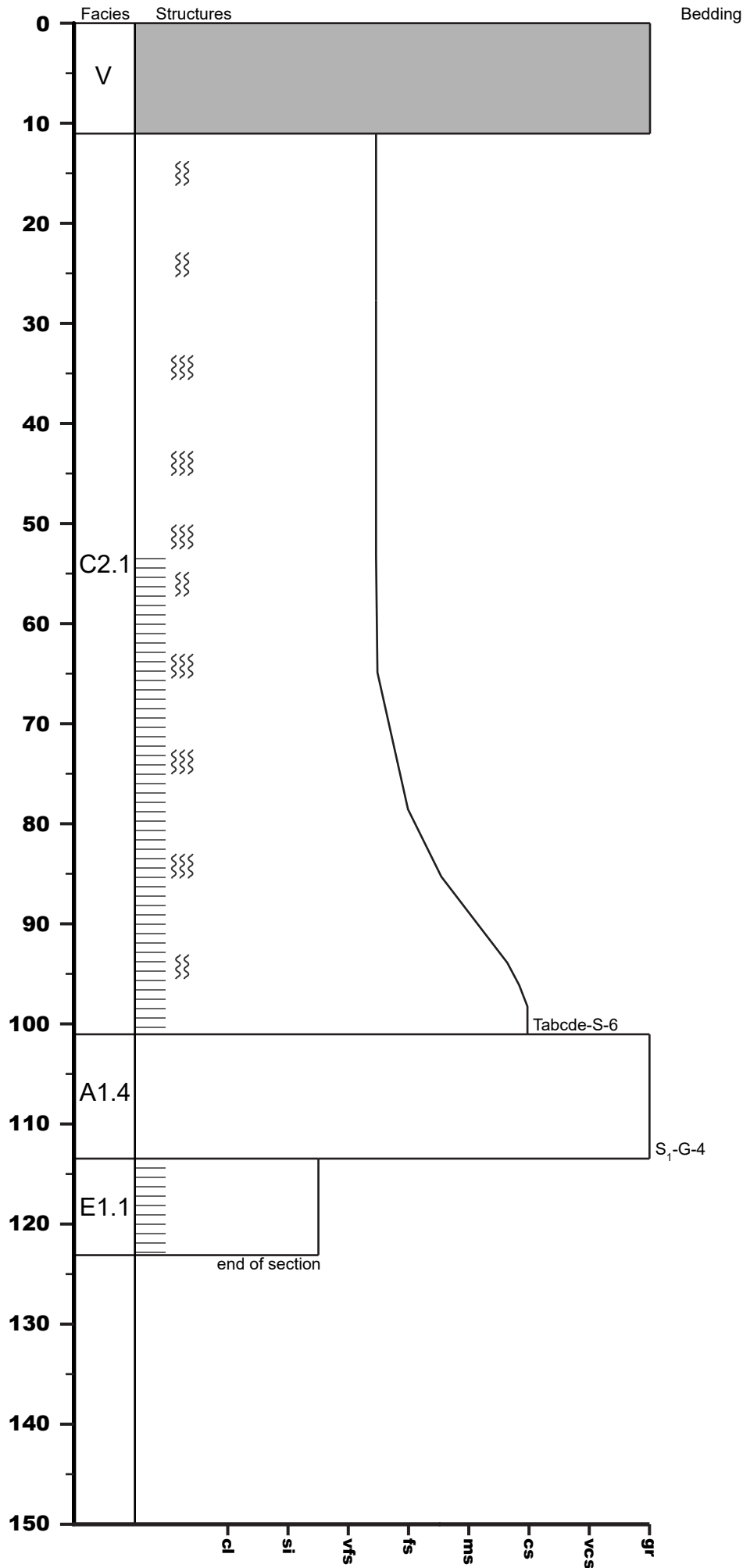

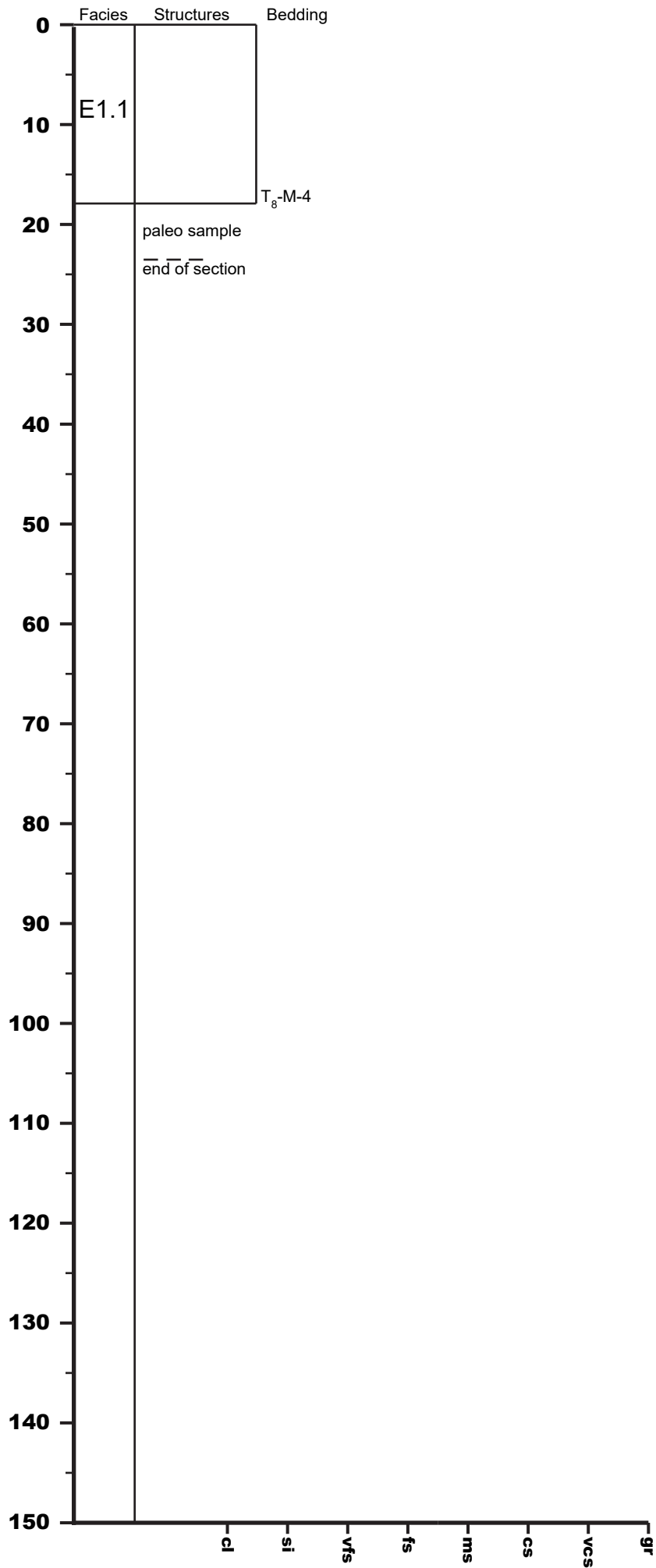

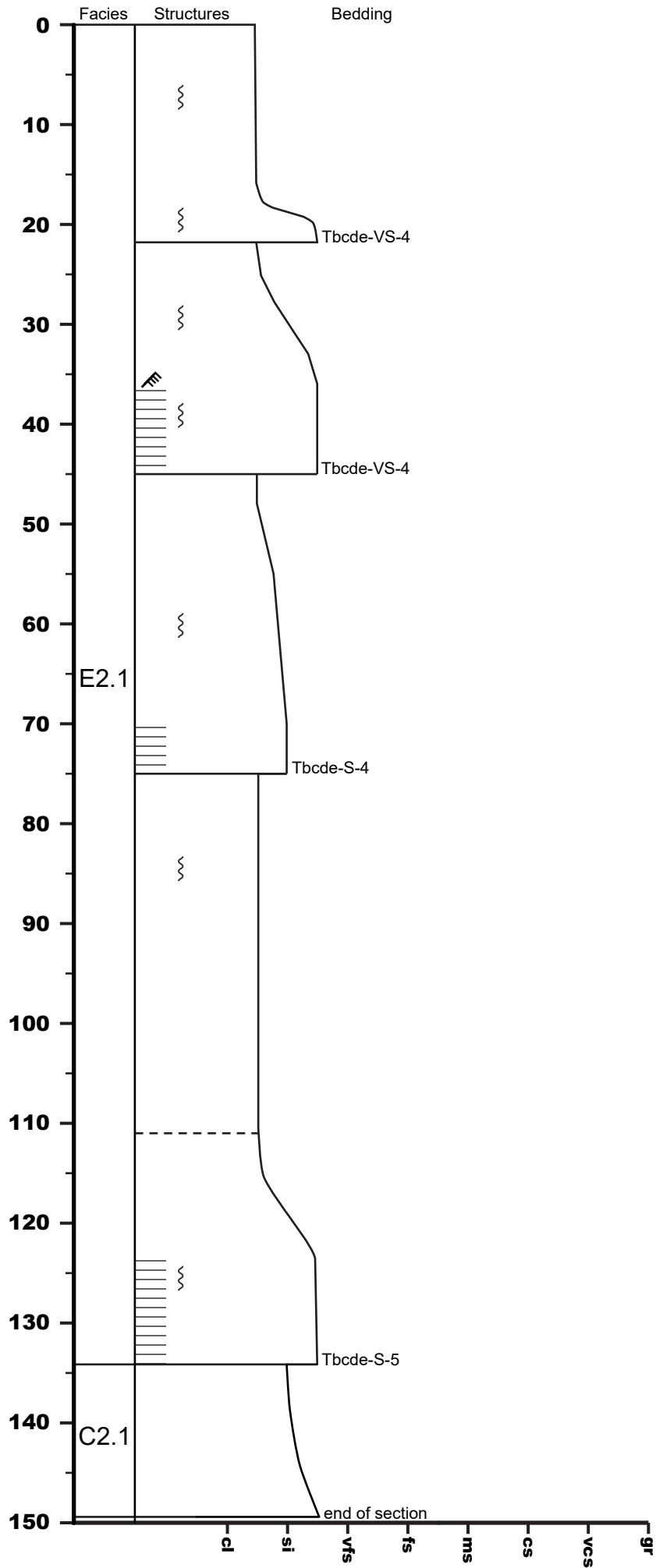



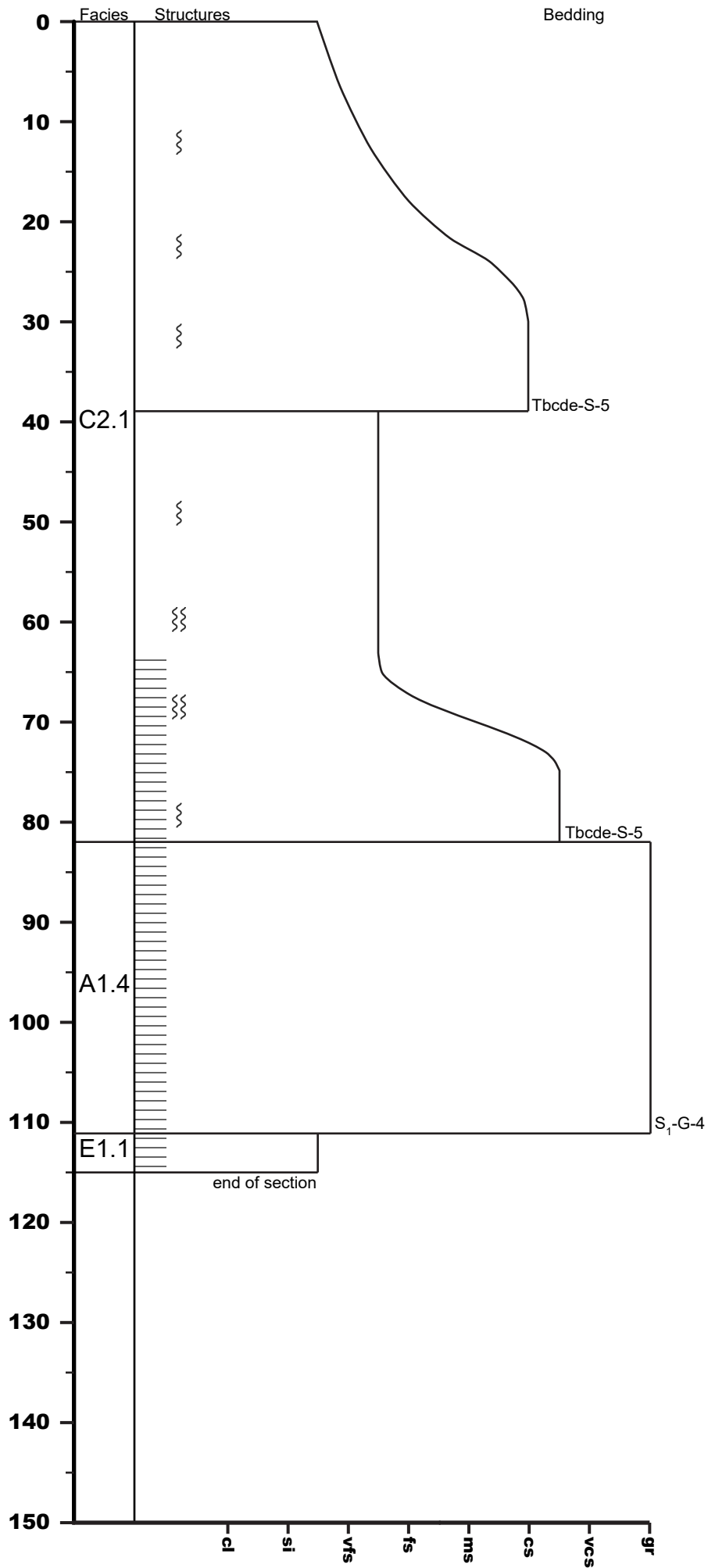

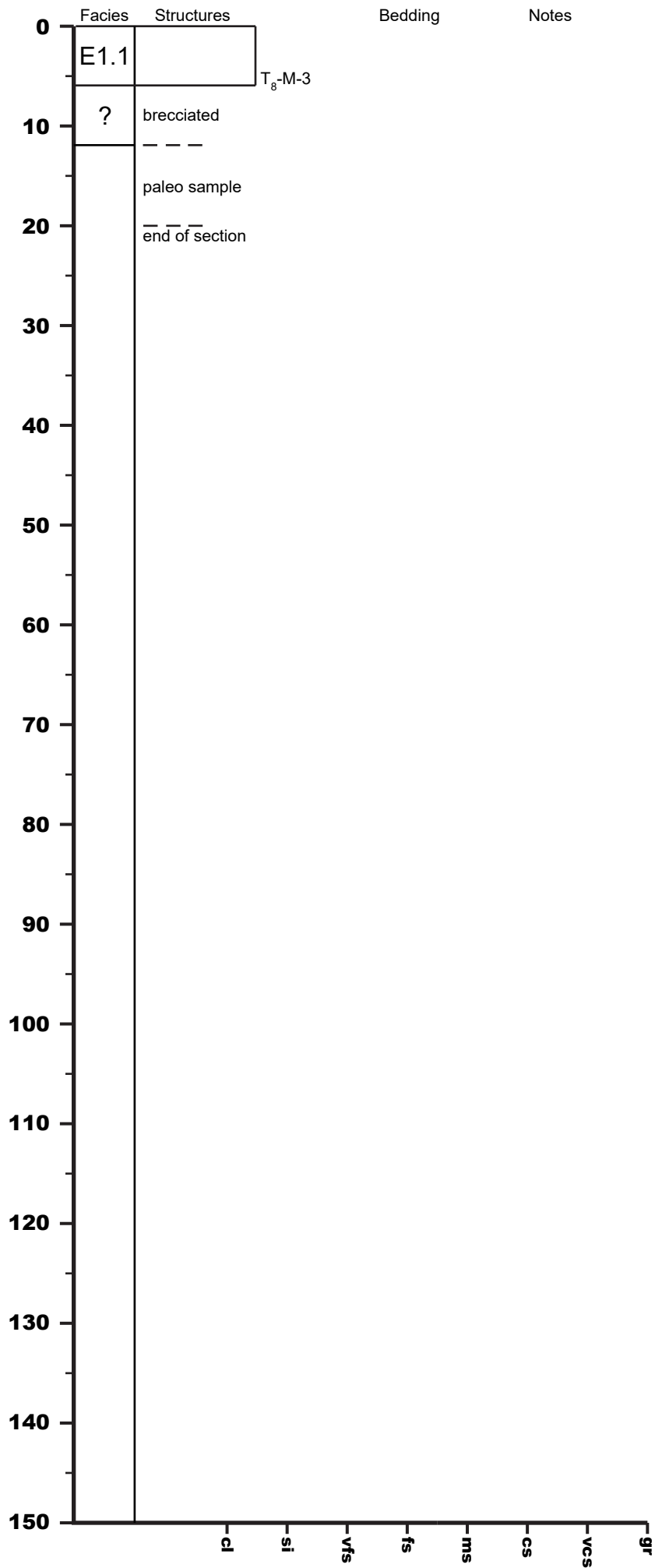

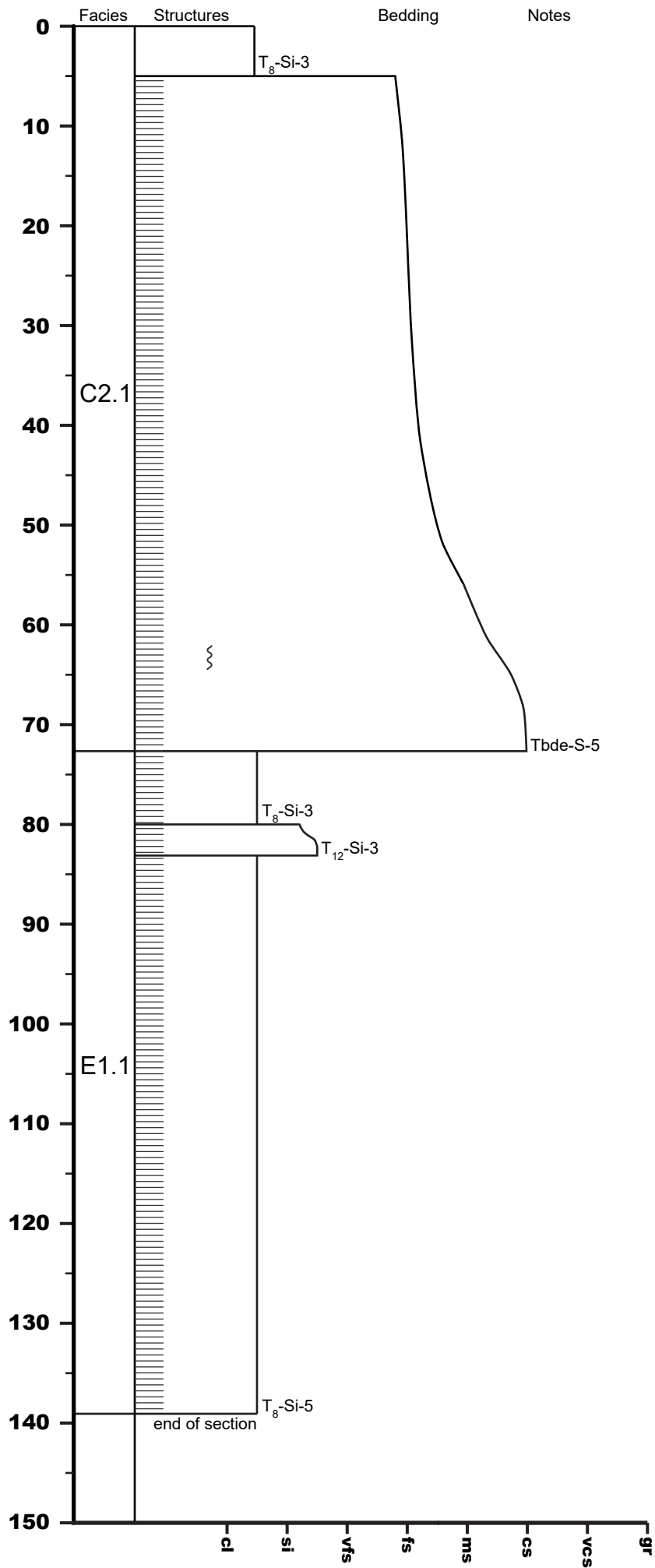

U1438E-64R-2

1430.1 - 1431.46 mbsf

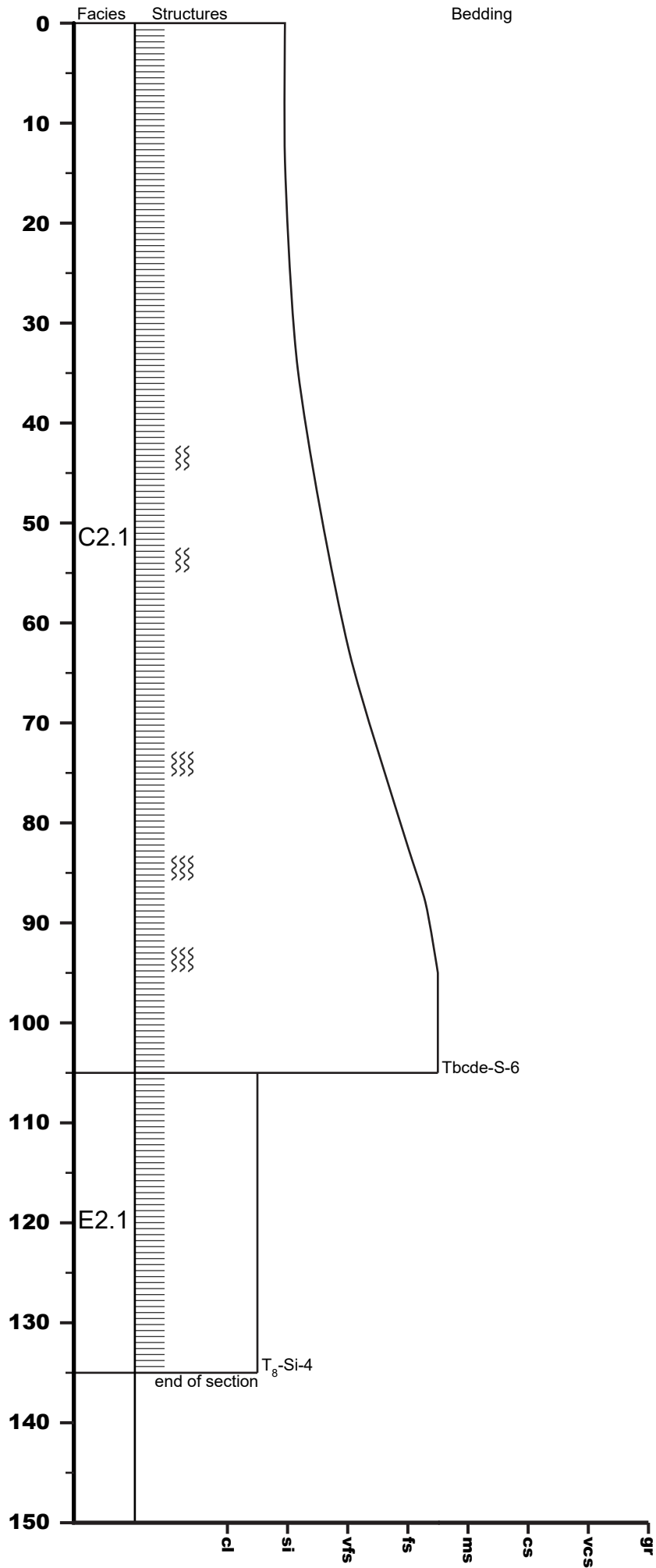

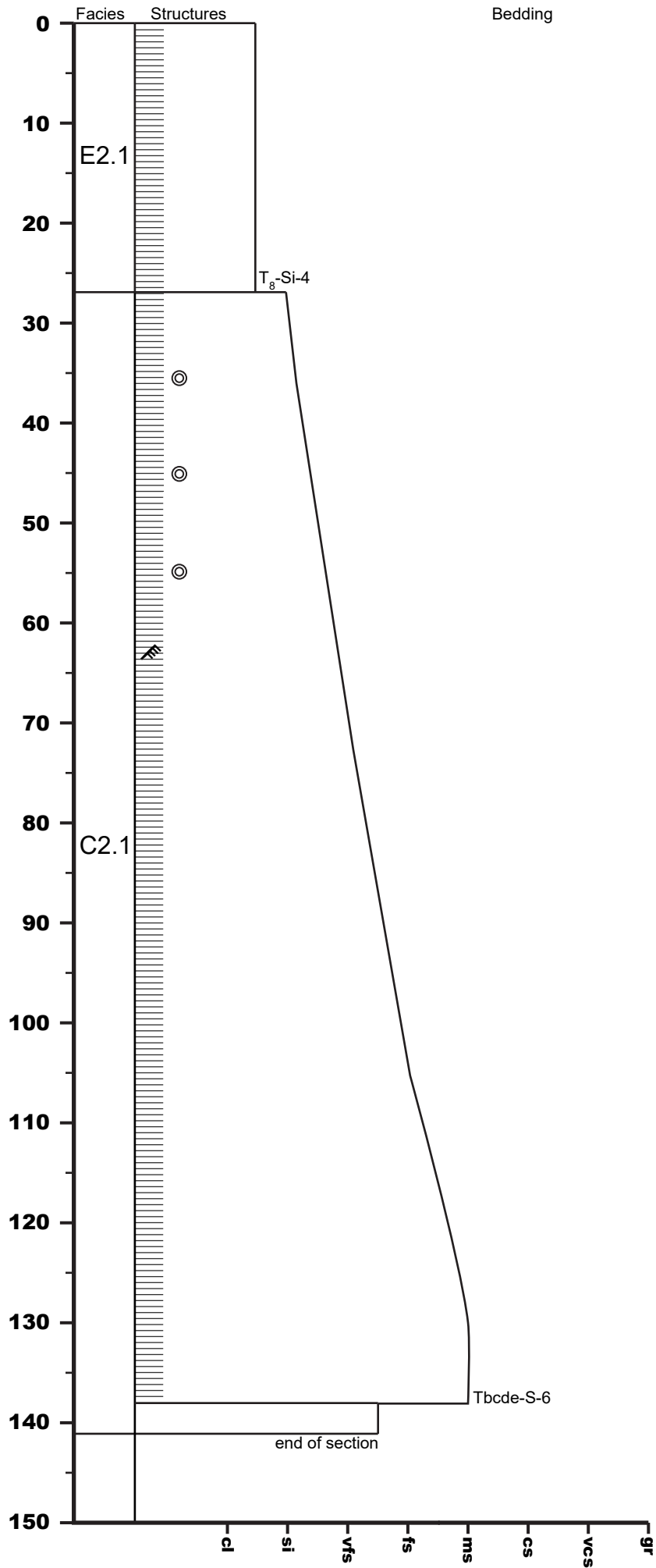

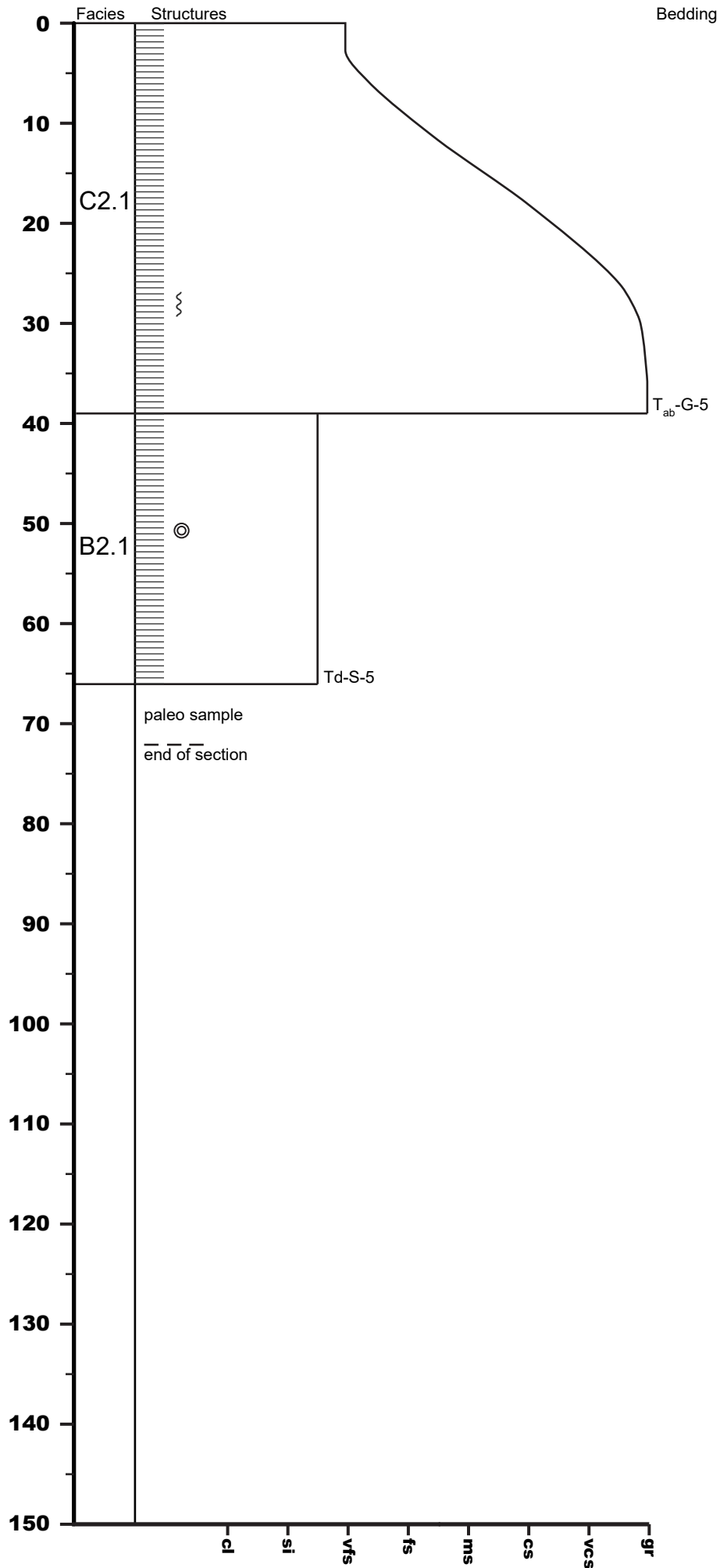

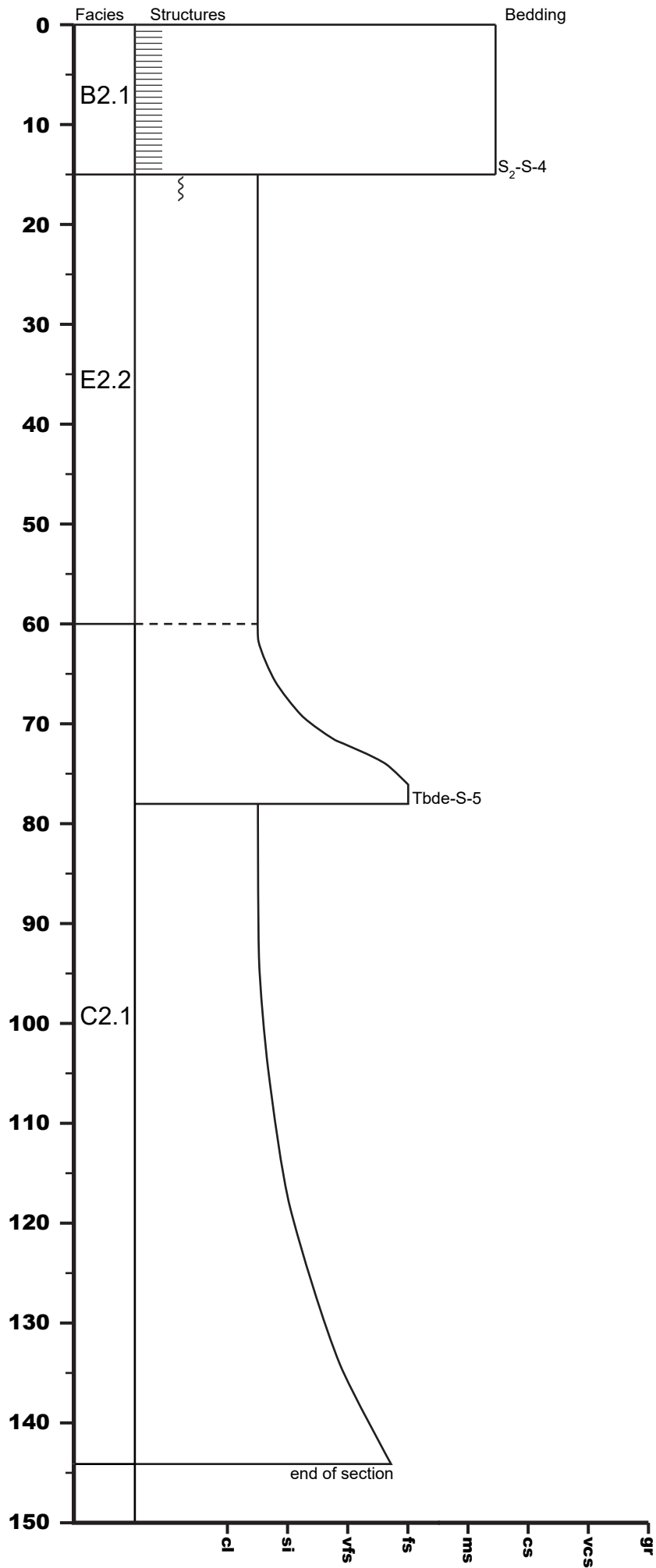

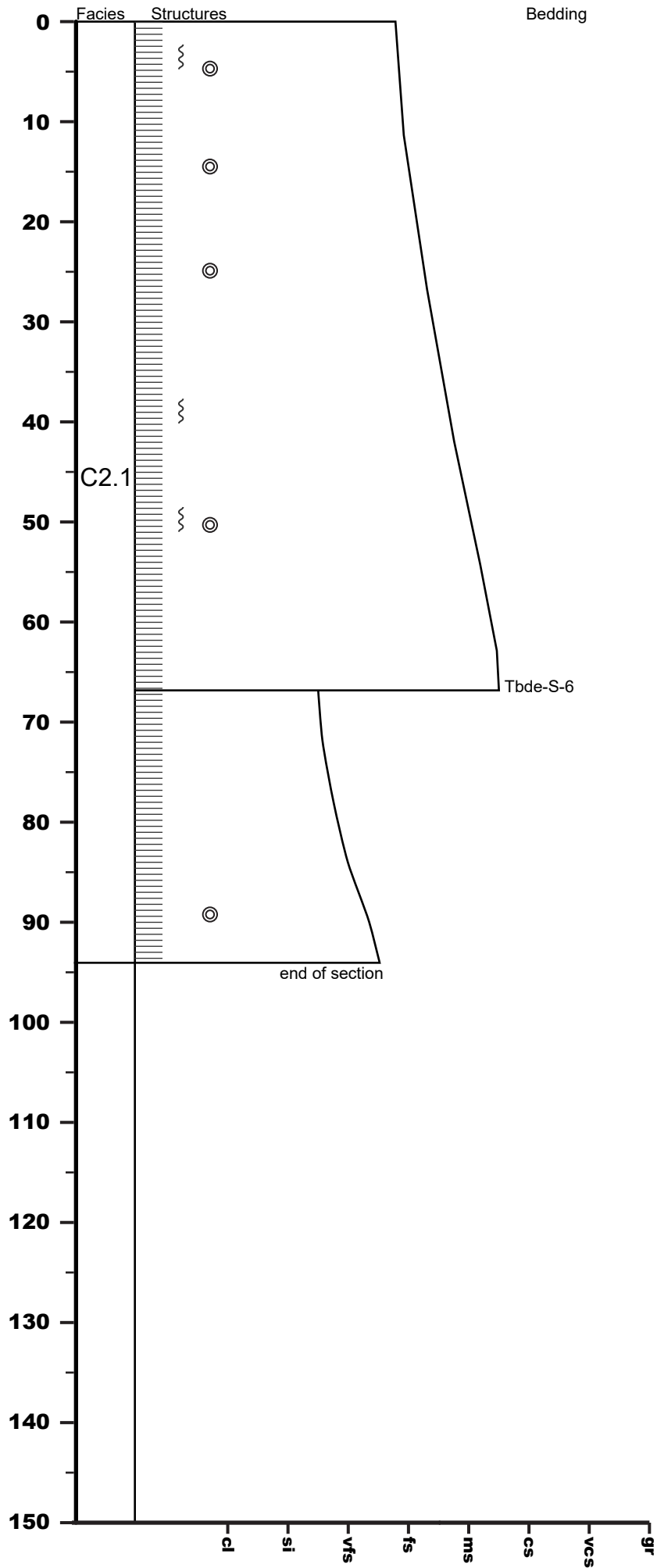



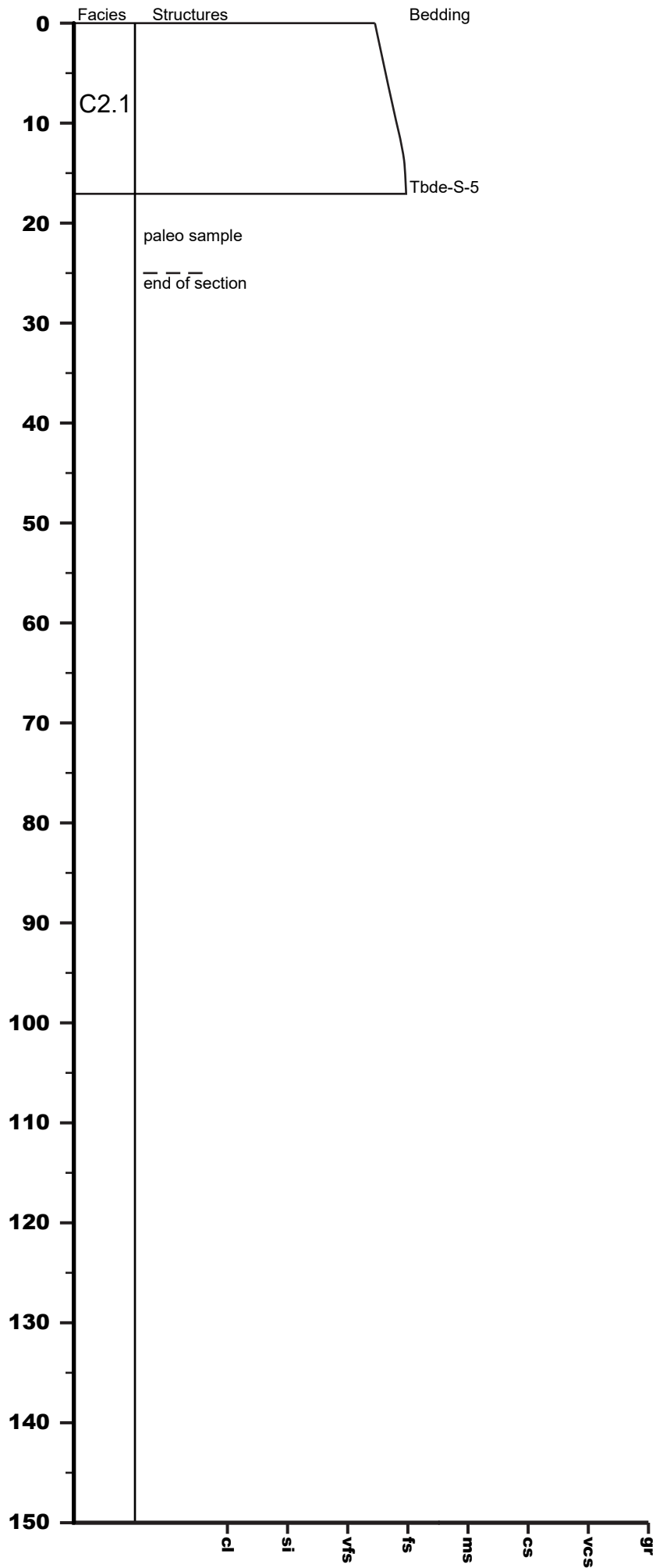

U1438E-66R-1

1447.1 - 1447.92 mbsf

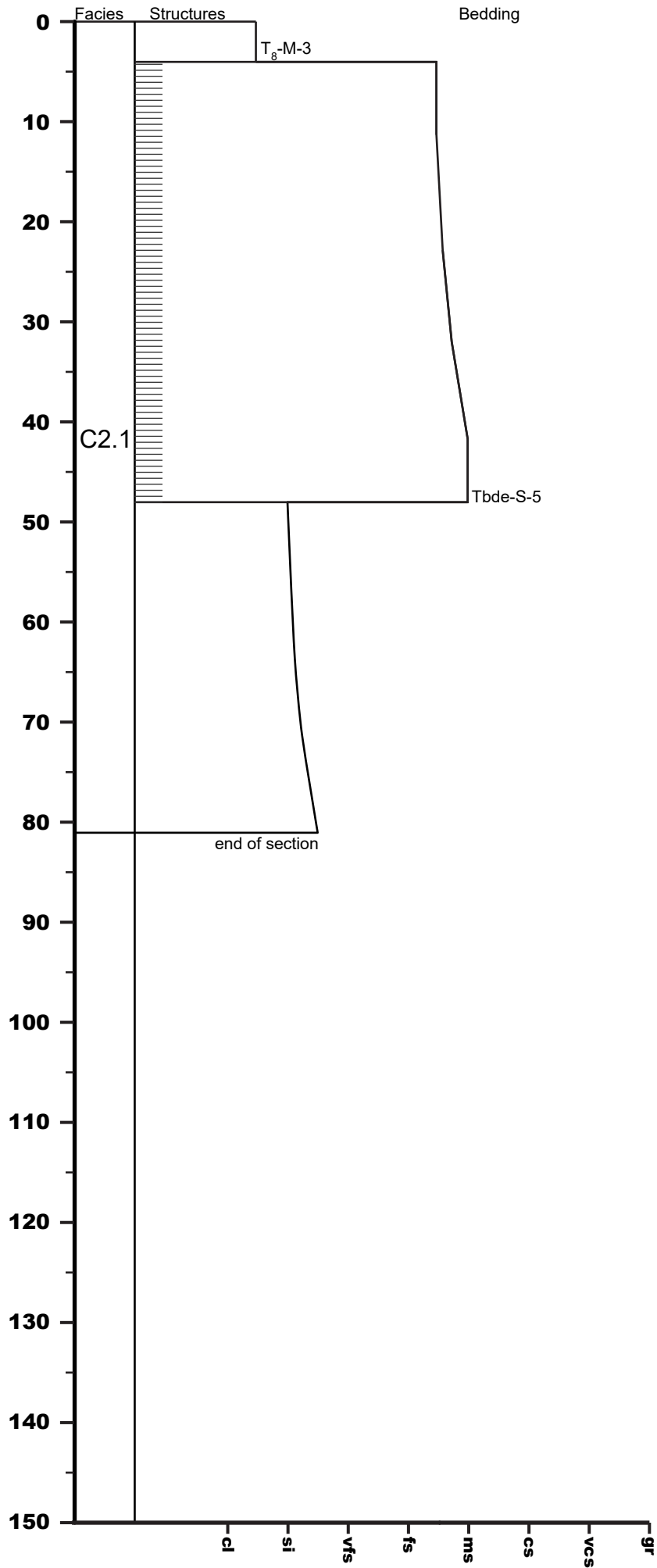

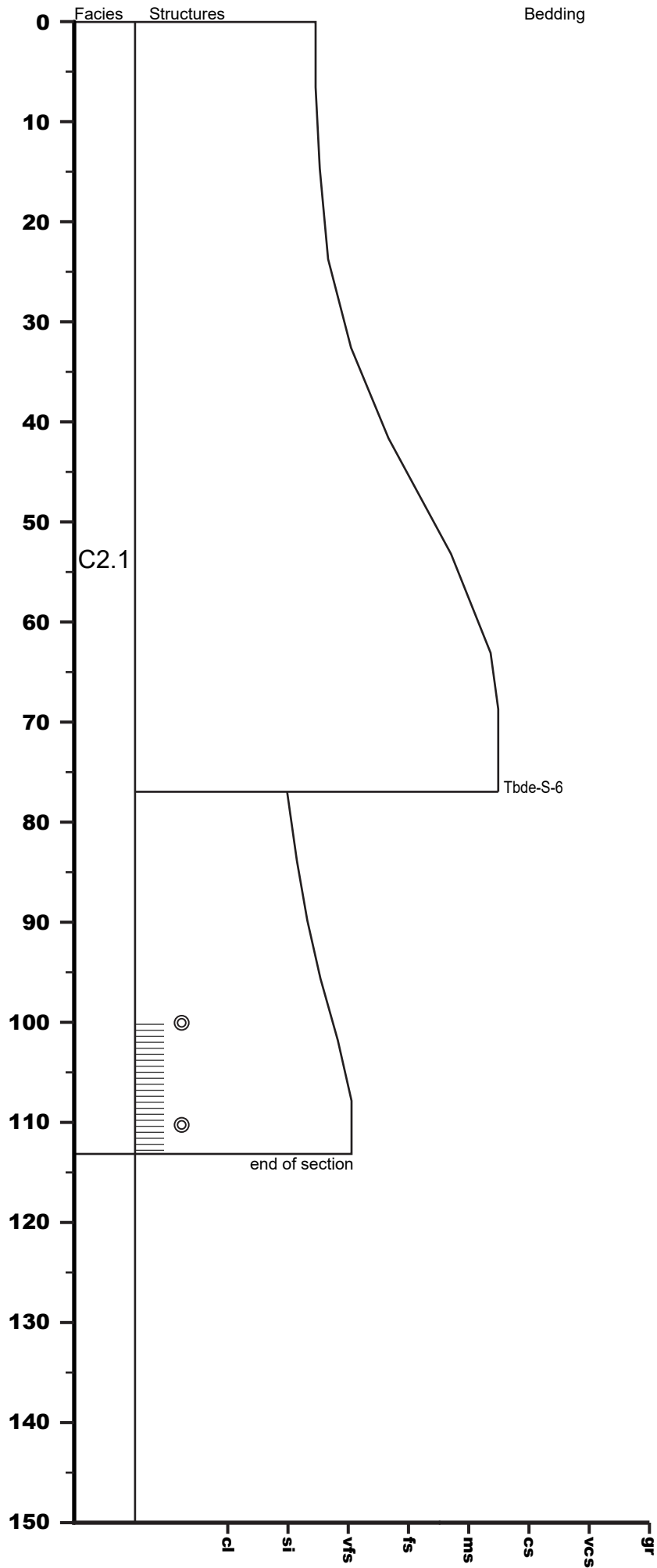

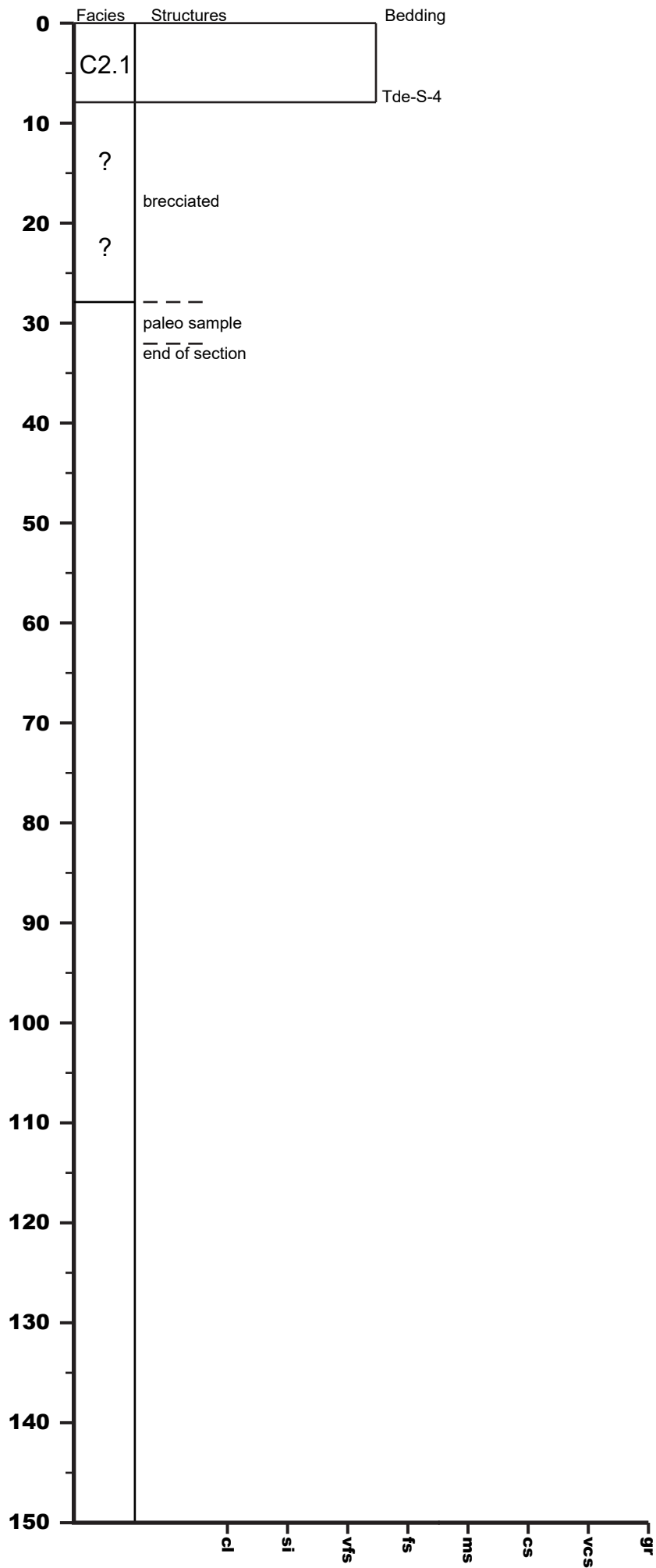

U1438E-67R-1

1451.7 - 1452.98 mbsf

